

High-speed Optical Transmission System for Backbone Networks

Kazutaka Sakai
Kagehiro Yamamoto
Kiichirou Taima
Ichirou Ishikawa

OVERVIEW: Hitachi has developed a variety of high-speed optical transmission systems for implementing ring networks that meet the needs of large-capacity backbone networks. (1) The 10-Gbit/s SONET (synchronous optical network)/SDH (synchronous digital hierarchy) and 2.4-Gbit/s SDH optical transmission systems, compliant with SONET and SDH international standards, use a bi-directional line switched ring or a unidirectional path switched ring switching function to provide highly reliable ring networks. (2) The dense wavelength division multiplexing system supports a transmission capacity of up to 1.28 Tbit/s (10 Gbit/s per wavelength \times 128 wavelengths) and provides flexibly expandable networks using an optical add-drop multiplexer function that can drop or add a multiplexed wavelength at a mid-point node. (3) The transparent transponder multiplexer system can transparently multiplex and transmit operation and management information from a low-speed interface side to a high-speed interface side, thereby flexibly accommodating various devices into high-speed networks.

INTRODUCTION

COMMUNICATION traffic volumes have been increasing rapidly, especially due to the widespread proliferation of the Internet protocol (IP), accelerating the need for large-capacity backbone networks. Responding to this situation, Hitachi delivered a 10-Gbit/s synchronous optical network (SONET) optical transmission system in 1997. Hitachi has since developed a dense wavelength division multiplexing (DWDM) system using optical wavelength multiplexing and an optical add-drop multiplexer (OADM) that has optical cross-connect and optical add-drop functions. These systems can be used to construct large-capacity optical networks (up to 1.28 Tbit/s). In addition, Hitachi developed a transparent transponder multiplexer (transmux) to enable high-speed IP routers and existing 2.4-Gbit/s or lower speed systems to be incorporated into a 10-Gbit/s backbone network. This system lineup enables Hitachi to provide large-capacity optical network solutions.

The following sections describe some of the features of these high-speed optical transmission systems and suggest network applications that can be built using them, especially ones using a transmux.

LARGE-CAPACITY OPTICAL NETWORK SOLUTIONS

When building a large-capacity network, it is important to provide optimum and cost-effective solutions that meet a variety of needs, such as the capacity of the network in which the systems are to be applied (total transmission capacity, transmission distance, etc.) and the type of interfaces to be supported.

To meet these needs, Hitachi has developed a system lineup that provides a variety of solutions. The networks that Hitachi proposes are basically configured by combining DWDM systems and optical transmission systems compliant with the SONET synchronous digital hierarchy (SDH) international standards. Other application systems are incorporated when required. Fig. 1 shows the optical transmission systems Hitachi provides to support various forms of backbone networks.

Backbone Networks

Hitachi provides large-capacity and medium-capacity systems for backbone networks covering a transmission distance (span) of 450 km. The major products for this type of network are:

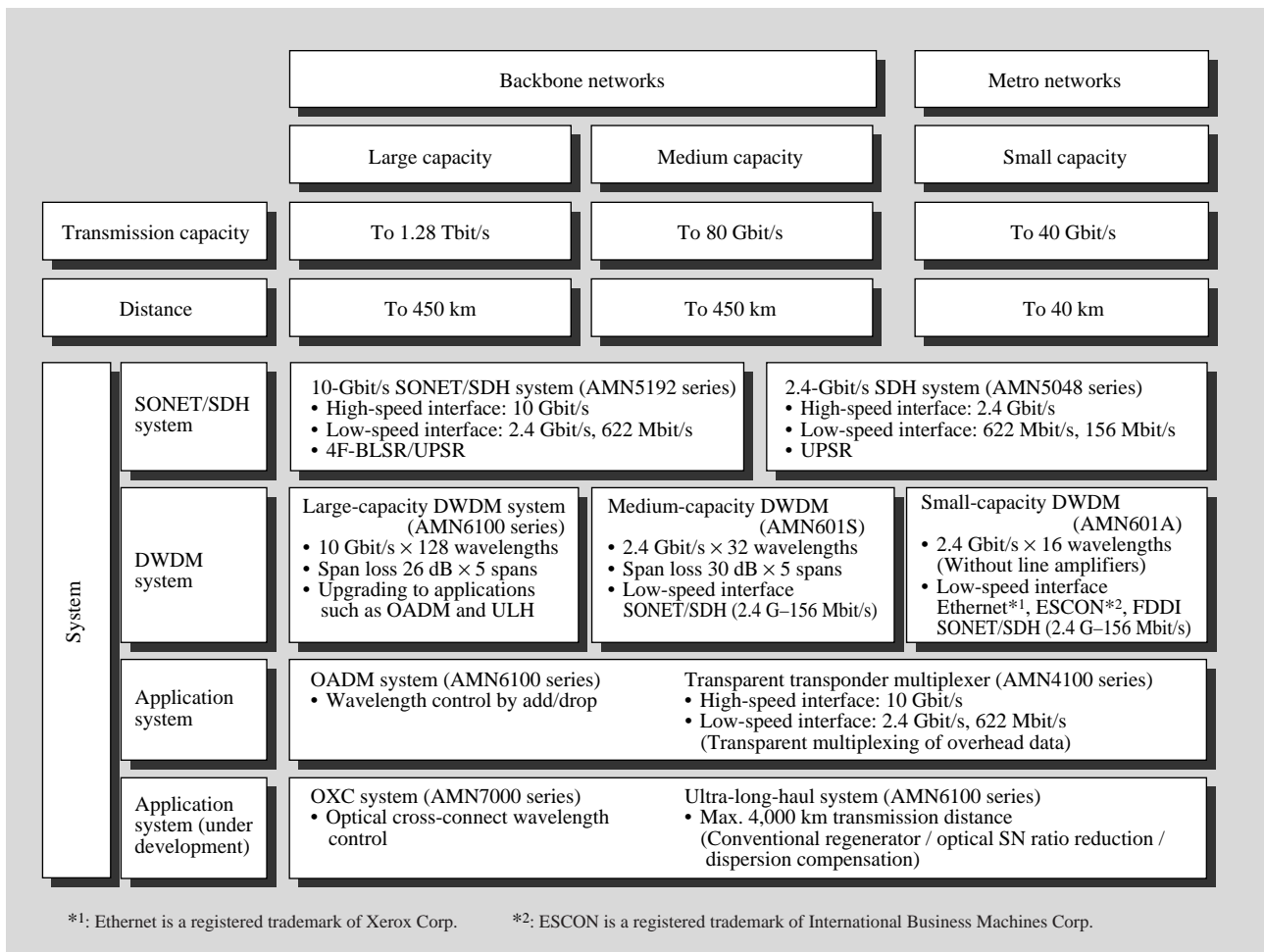

Fig. 1—Optical Transmission Systems Supporting Various Forms of Backbone Networks.

Hitachi provides products to support various forms of backbone networks. Backbone networks are basically formed by combining SONET/SDH and DWDM systems. OADM systems, transmux systems, and other components are incorporated depending on network applications.

(1) 10-Gbit/s SONET/SDH system (AMN5192 series)¹⁾

This 10-Gbit/s transmission system is compliant with the SONET/SDH standards. It enables creation of ring networks and is highly reliable against network failures because it uses bi-directional line switched ring (BLSR) or unidirectional path switched ring (UPSR) switching functions.

(2) Large-capacity DWDM system (AMN6100 series)

This DWDM system has a maximum transmission capacity of 1.28 Tbit/s (10 Gbit/s per wavelength × 128 wavelengths) and a standard transmission distance of 450 km, using the wavelength-multiplexing and optical-amplification functions.

Metro Networks

A network configuration with a transmission

distance of less than 40 km is considered a metro network. The major products for this type of network are:

(1) 2.4-Gbit/s SDH system (AMN5048 series)

This 2.4-Gbit/s transmission system is compliant with the SDH standard and enables creation of ring networks. It uses the UPSR switching function, which is well suited to the star-type traffic patterns typically found in urban areas.

(2) Small-capacity DWDM system (AMN601A series)

This DWDM system multiplexes 2.4-Gbit/s signals per wavelength to 16 wavelengths at the maximum. To cover the various interfaces found in metro networks, it supports low-speed interfaces such as SONET/SDH, Ethernet, ESCON, Fiber Channel, and FDDI.

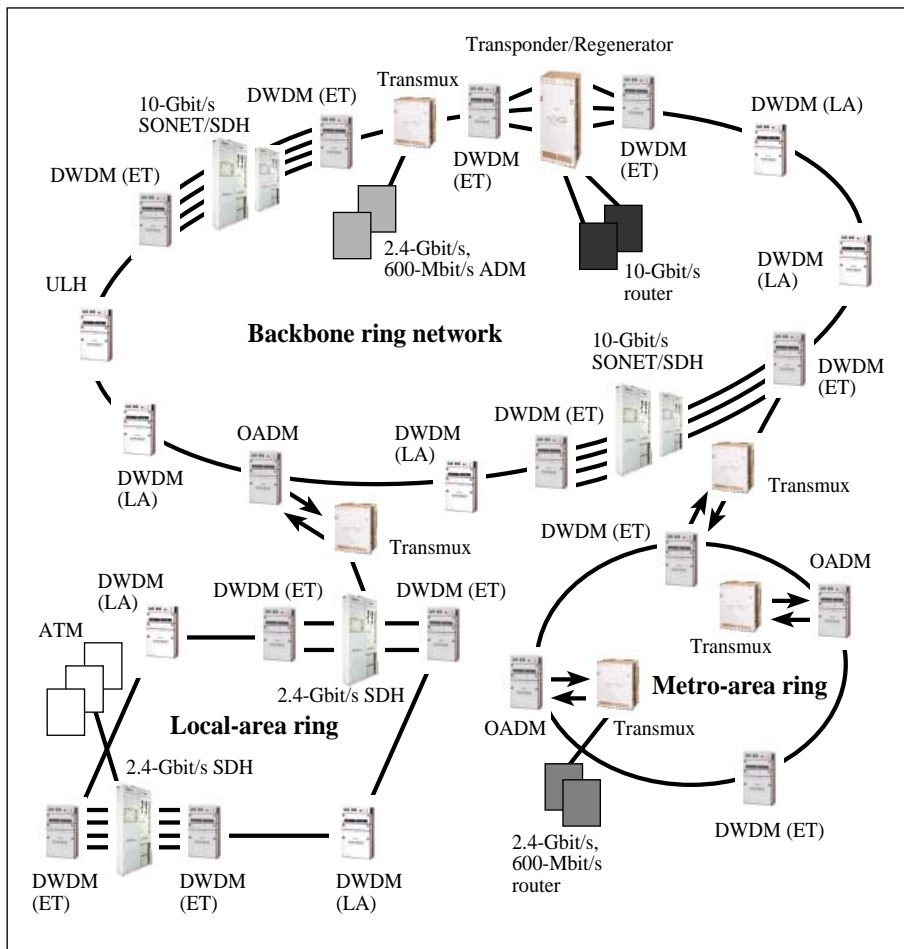

DWDM: dense wavelength division multiplexing
 ET: end terminal
 LA: line amplifier
 ULH: ultra long haul
 OADM: optical add-drop multiplexer
 Transmux: transparent transponder multiplexer
 ATM: asynchronous transfer mode

Fig. 2—Example Backbone Network Configuration Using Hitachi's Optical Transmission Systems. Combining DWDM and 10-Gbit/s SONET/SDH systems enables optimum ring networks to be built for large-capacity backbone networks. This example is a network configuration using OADM or transmux systems for connecting backbone networks and accommodating ATM or IP routers in a backbone network.

Application Systems

(1) Transparent transponder multiplexer system (transmux, AMN4100 series)

This 10-Gbit/s transmission system is compliant with the SONET/SDH standards and enables existing applications to be supported in a backbone network without change. It will be described in detail in the next section.

(2) OADM/ULH system (AMN6100 series)

The OADM system adds signals of any wavelength to or drops them from the wavelengths multiplexed by the DWDM system. This system allows service requests to be handled on a per-wavelength basis.

An ultra-long-haul (ULH) system can provide transmission distances of more than 4,000 km by using conventional regeneration technology, optical SN ratio reduction, and dispersion-compensation technology.

Both systems can be provided on appropriate function cards in a large-capacity DWDM system.

(3) OXC system (AMN7000 series)

This optical cross-connect (OXC) system provides a switching function on a per-wavelength basis and

allows the construction of linear-, ring-, or mesh-type networks.

Fig. 2 shows an example network configuration consisting of some of these systems.

FEATURES OF TRANSMUX SYSTEM

The transmux (transparent transponder multiplexer) system was developed to support various applications of backbone networks. Fig. 3 shows the configuration, and Table 1 shows the major specifications. The features of the system are as follows.

Transparent Multiplexing Transmission

The basic function of the transmux is to multiplex 2.4-Gbit/s or 600-Mbit/s signals into 10-Gbit/s signals, the same as conventional multiplexers do. One of the most striking characteristics is that the system can transparently multiplex and transmit operation and management information simultaneously. Moreover, the system can transparently multiplex and transmit overhead information about operation and management through low-speed interfaces to the high-

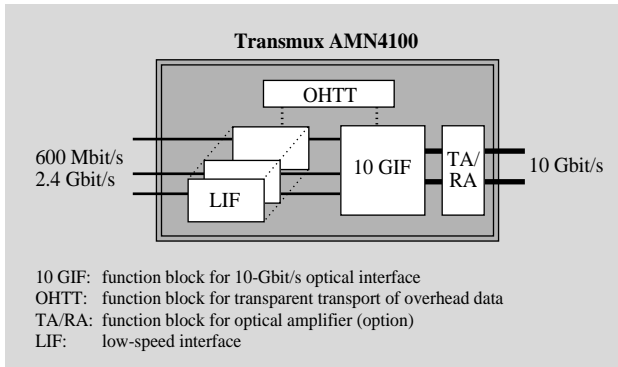

Fig. 3—Configuration of AMN4100 Transparent Transponder Multiplexer System (Transmux).

speed side as is, thereby conveying the information to the low-speed device at the other end. In conventional multiplexers, overhead information through low-speed interfaces cannot be conveyed to the other-end device because of the termination processing. This means that complete unification of network management layer is required. This unification is an important part of managing the low-bandwidth lines of a telephone-dominated network, but in turn this becomes complicated and inappropriate when optical signals originating in high-speed IP routers should be transmitted transparently.

The transparent multiplexing transmission function enables incorporating lower speed devices into higher

speed transmission systems while retaining the operation and management functions of existing networks. In addition, the network can accommodate not only SONET/SDH systems but also IP routers and ATM units, as shown in Fig. 4, by the use of a concatenation processing function.

Transponder Function

This system supports the ITU-T (International Telecommunications Union-Telecommunication Standardization Sector) standard of 64 wavelengths for DWDM as the 10-Gbit/s interface. With a variable-optical-output-type optical amplifier card, this system can be supported in current DWDM systems.

Stand-alone Configuration

This system can provide a transmission distance of 135 km in a single-point to single-point configuration when an optical amplifier card is installed in the high-speed interface section. Therefore, the system can be used for local backbone networks, for which a ring network is not appropriate, such as the data center inter-networks of Internet service providers.

High Reliability by Optical Switch

An optical switch can be provided in the optical amplifier section to support a redundant configuration

TABLE 1. Major Specifications of AMN4100 Transparent Transponder Multiplexer
 The transmux, a 10-Gbit/s optical transmission unit, can accommodate four systems per rack and transparently transmit six types of overhead information.

Item	Specification/Performance
Specification	Bellcore GR-253-CORE
Mounting	4 systems/rack (40 Gbit/s/rack)
Transponder	10 Gbit/s (OC192/STM-64) Wavelength ITU grid
Multiplexer	600 Mbit/s (OC12/STM-4) × Max. 16 2.4 Gbit/s (OC48/STM-16) × Max. 4
Transparent transport	Treatment of overhead bytes • D1-D12 (DCC) • E1, E2 (order wire) • F1 (User byte) • K1, K2 (APS) • B2 (Line-BIP) • M1 (Line-REI)
Span distance	135 km (need to reach optical amplifier)

OC: optical carrier APS: automatic protection switching
 STM: synchronous transport module BIP: bit interleaved parity
 DCC: data communication channel REI: remote error indication

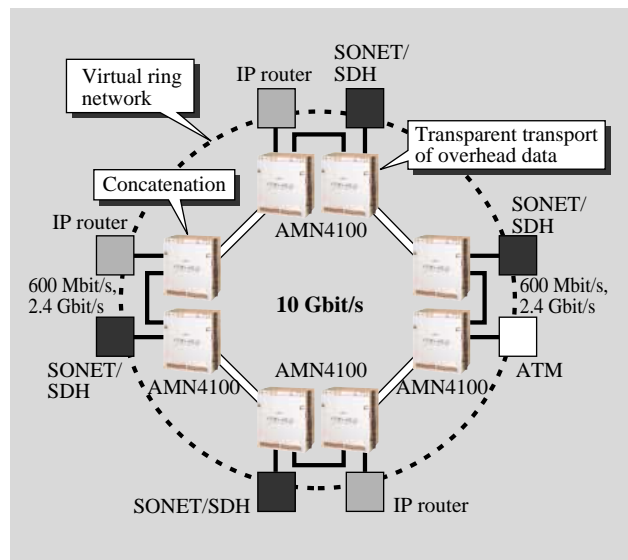

Fig. 4—Example Application Using AMN4100 Transparent Transponder Multiplexer (Transmux).

This system can transparently multiplex overhead information about management in low-speed interfaces into a 10-Gbit/s interface while retaining the operation and management functions of a conventional SONET/SDH transmission system.

with 10-Gbit/s optical transmission paths (optical 1+1 protection). This application allows creating an optimum system that meets the users' needs, one that includes a BLSR/UPSR highly reliable network, 1+1 protection for maintenance or protection against failures in the optical transmission paths, and low operational cost without a redundant configuration.

Compact Design

This system uses a unit-type design. The unit size is 45 cm (height) × 59 cm (width) × 31 cm (depth).

Up to four systems can be mounted in a standard 7-foot rack that is compliant with the North American NEBS standard. One rack can support the capacity needed for 40-Gbit/s transmission.

CONCLUSIONS

Hitachi has a system lineup for backbone network solutions. The backbone networks are basically configured by combining of SONET/SDH high-speed optical transmission systems and DWDM systems, and are expandable by adding application systems that meet the users' needs. In particular, a transparent transponder multiplexer (transmux) system can be used for application systems. Networks using this transmux system can be easily accommodated into high-speed interfaces. We will continue developing network products to meet users' needs and work toward improving solutions for backbone networks.

REFERENCE

- (1) T. Mori et al., "Ultra High-Speed SONET Fiber-Optic Transmission System," *Hitachi Review* **47**, 79-84 (Apr. 1998).

ABOUT THE AUTHORS



Kazutaka Sakai

Joined Hitachi, Ltd. in 1986, and now works at the Telecommunication System Group. He is currently engaged in the development of a 10-Gbit/s optical transport system. Mr. Sasaki is a member of the Institute of Electronics, Information and Communication Engineers of Japan, and can be reached by e-mail at kazutaka_sakai@cm.tcd.hitachi.co.jp.



Kagehiro Yamamoto

Joined Hitachi, Ltd. in 1981, and now works at the Telecommunication System Group. He is currently engaged in the development of a DWDM system. Mr. Yamamoto can be reached by e-mail at kagehiro_yamamoto@cm.tcd.hitachi.co.jp.



Kiichirou Taima

Joined Hitachi, Ltd. in 1983, and now works at Hitachi Telecom (USA), Inc. He is currently engaged in the development of a 10-Gbit/s optical transport system and a DWDM system. Mr. Taima can be reached by e-mail at kiichiro.taima@hitel.com.



Ichirou Ishikawa

Joined Hitachi, Ltd. in 1982, and now works at the Telecommunication & Information Infrastructure Systems. He is currently engaged in the sales of optical transport system and the DWDM system. Mr. Ishikawa can be reached by e-mail at ichiro_ishikawa@cm.tcd.hitachi.co.jp.