

# Information Systems

Solution Services

Software

Hardware

Network Systems

Image and Information Equipment

e-Learning

Communication Devices

# Digital Pen Solution for Seamless Integration of Paper and Information Systems

An increasing number of digital devices, such as PCs, mobile phones, and PDAs, are becoming available, and business operations are becoming more and more digitized. However, it is anticipated that the demand will remain high for conventional paper-based procedures, such as various application systems at the government-window counter. Hitachi provides a Digital Pen Solution that efficiently integrates paper-based procedures and information systems.

The solution enables one to use pen and paper in a conventional way while enhancing work efficiency. When something is written with a pen, the system instantly recognizes the form on which it was written, enabling handwritten data to be automatically transferred to an appropriate application system. Moreover, the character recognition function eliminates the need to retype the data. The three main components of the Digital Pen Solution are as follows.

## (1) Digital Paper

The Digital Paper contains small dots placed in a special pattern. These dots can be printed on any standard type of paper. They are placed in a 0.3-mm square grid with slight slippage, up, down, left, or right. Since there are  $6 \times 6$  dots in a unit, the combination of slippage patterns with 36 dots is  $436$ , which provides a great number of unique patterns that can be treated as coordinates in a vast area.

## (2) Digital Pen

As the Digital Pen is used to write something, a built-in camera captures the dot pattern of the Digital Paper, thereby identifying its absolute coordinates. The pen can also recognize the pen pressure on the paper, the time the writing was done, and the angle between the paper and the pen. These data are processed and stored in a built-in memory, then transmitted to a PC via Bluetooth\* or a USB (universal serial bus).

## (3) Enterprise paper look-up service (EPLS) server

There is a database in the EPLS server that is used to match the coordinates of the dot patterns with the URL address of the application system. When the pen sends the coordinates, the EPLS server finds the appropriate URL and sends it to the pen. The pen then sends the data to the appropriate application.

Digital Pen Solution can be used in various types of organizations including governments and private companies. In the financial area, for instance, it can be used for insurance enrollment. Hospitals can use it for routine updating of medical records. Another potential application is maintenance and inspection work. Hitachi considers this solution to be the key to seamlessly integrating paper and information systems in various areas. To achieve this goal, Hitachi is jointly developing this solution with Anoto\* and aims to complete the co-development by July 2003.

\* See "Trademarks" on page 87.

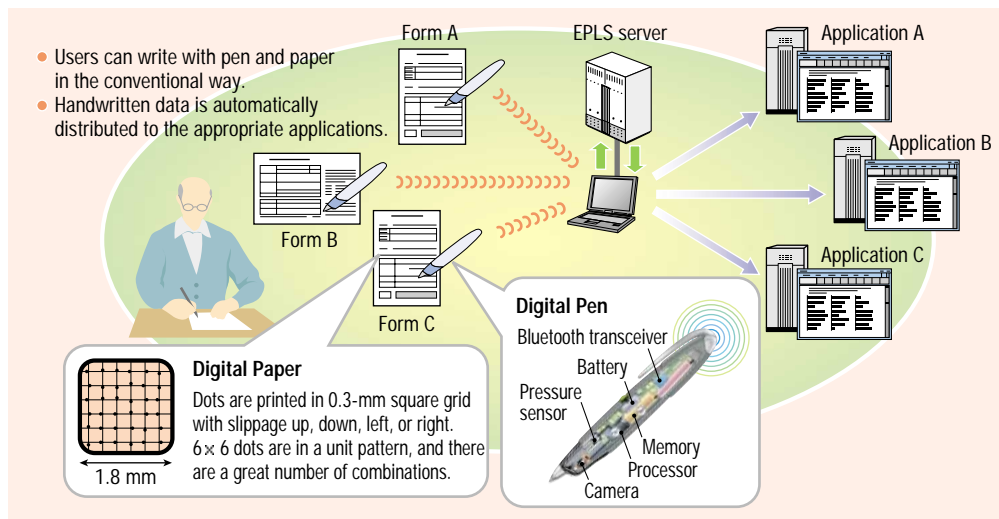

Overall system image of Digital Pen Solution

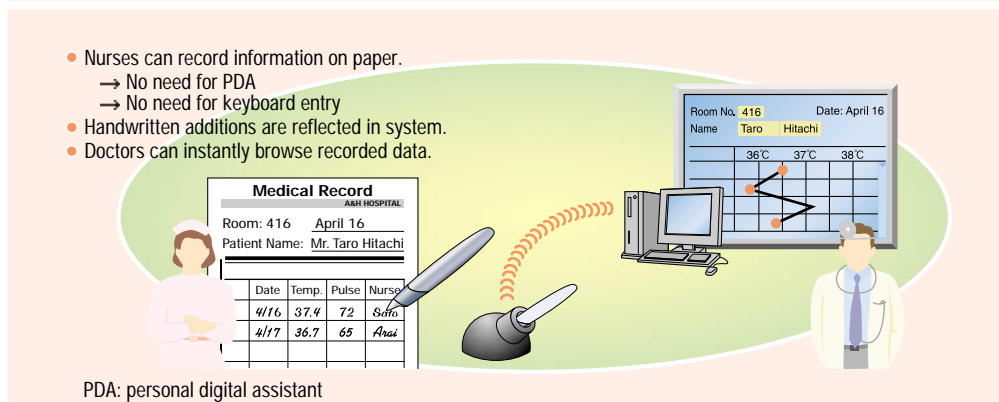

Routine-run medical record by nurses

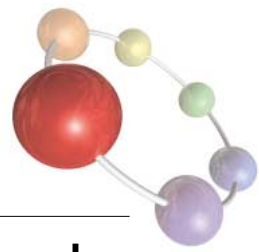

## Electronic Administrative Procedures Solution for Local Governments

Hitachi, Ltd. provides an electronic administrative procedures (application, registration, etc.) solution for local residents and businesses through the Internet. It is an efficient hybrid-type (both electronic and face-to-face services are provided) system composed of a portal site, administrative procedures software for the

Internet, and common software of administrative procedures for the Internet. It meets the needs of local governments and provides a secure and reliable system in a short period. It also meets the needs of local residents and businesses.

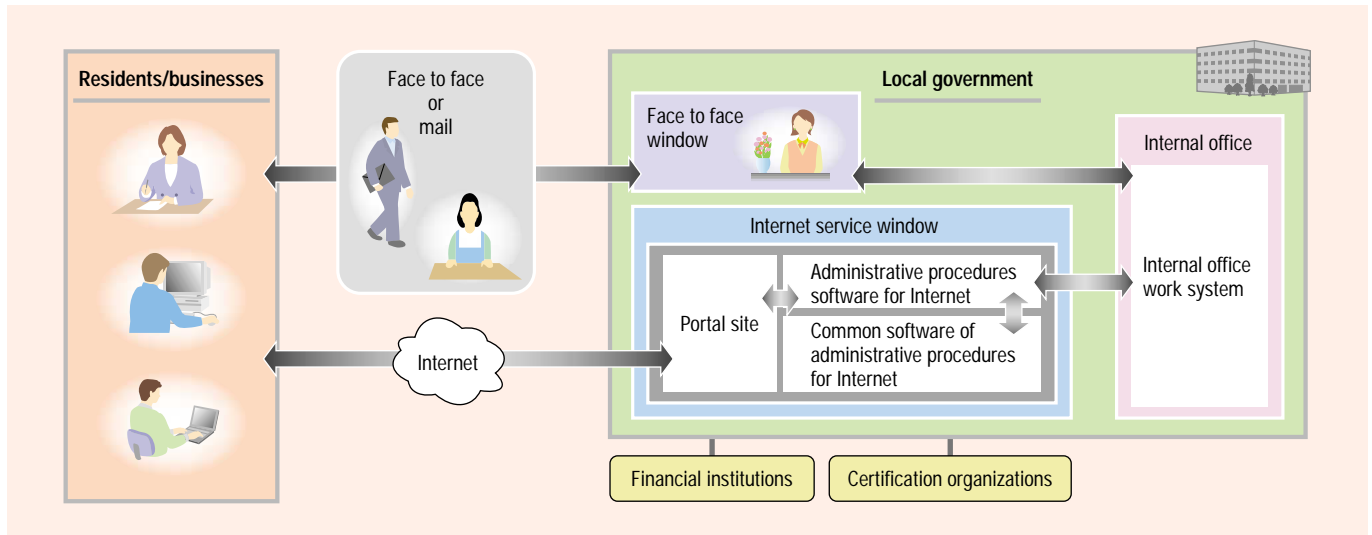

Overview of hybrid-type administrative procedures system

## Positional Information Management System "COCO SECOM" Operating at SECOM

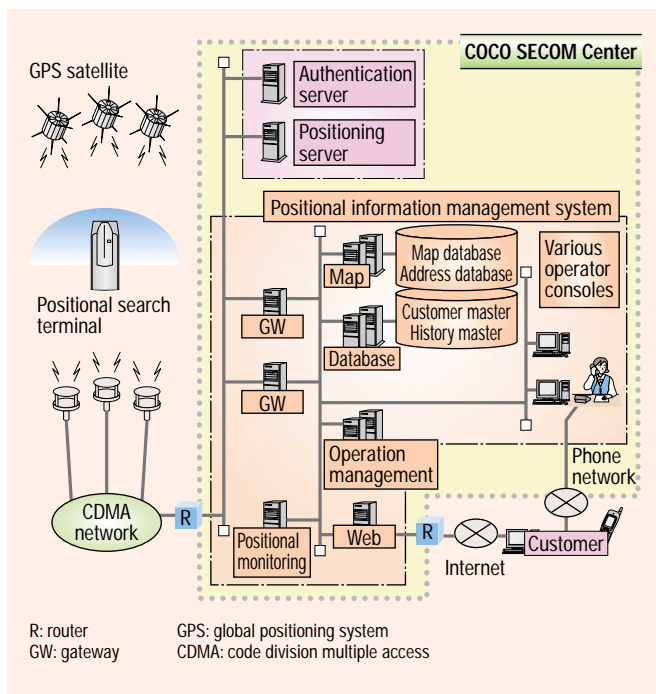

High-performance and highly reliable storage system

The Positional Information Management System "COCO SECOM\*," supplied by Hitachi to SECOM Co., Ltd., is comprised mainly of a gateway server, a positional monitoring/operation management server, a Web server, a map server, and an operating console.

This system maps positional information from a positional search terminal onto a map, and provides the subscriber with map image information. When information related to the position and status of the terminal in question exceeds certain set values, a failure notice is displayed on the operating console, and the subscriber is notified concurrently with trace monitoring and control instructions that are sent to the positioning terminal.

The individual functions of each server are multiple-redundant to ensure high reliability that enables 24-hr. continuous operation. Servers are installed in a distributed-load arrangement so that nodes can be added without service interruptions, to flexibly accommodate additional services and future increases in the number of subscribers.

\* See "Trademarks" on page 87.

# Package Software for Automobile Production Control System

HTC-NXAUTO is a remarkable product that improves automobile assembly line productivity, which is especially important in these highly competitive times, by eliminating costly downtime problems before they occur. This specialized software “pick&choose” package can be quickly set up and implemented. Then, as needs evolve and grow, additional elements can be easily incorporated because HTC-NXAUTO is designed for flexible expandability. This flexibility is due to the progressive open architecture design that allows the mixing of different, readily accessible, software packages and message management.

HTC-NXAUTO is a manufacturing execution system (MES) package especially designed for automotive plant process management. At the heart of HTC-NXAUTO is its “real-time tracking” ability. The current status of the production line can be monitored from any network PC. Hitachi’s Autonomous Decentralized System operates as an independent unit, enabling on-line testing without system interruptions. HTC-NXAUTO also enhances a plant’s capability to keep up with the trend toward mixed manufacturing for faster, more efficient delivery of final automotive products.

Advantages of HTC-NXAUTO:

- (1) HTC-NXAUTO is a specialized software package for automobile production.
  - Supports basic MES functions of production control system.
  - Decreases need for customization and shortens implementation schedule.
  - Incorporates many user query screens to support immediate production.
- (2) HTC-NXAUTO is designed for open architecture (Windows\*, Ethernet\*, etc.).
  - Supports commercial off-the-shelf components.
- (3) HTC-NXAUTO uses Hitachi’s Autonomous Decentralized System Architecture.
  - Enables each node (PC, server) on the network to operate independently.
  - Makes it easy to modify and expand what to meet the changing business environment (client/server system).
- (4) HTC-NXAUTO supports end-user computing.
  - Facilitates problem-free execution of on-line testing without risk of system interruption.

\* See “Trademarks” on page 87.

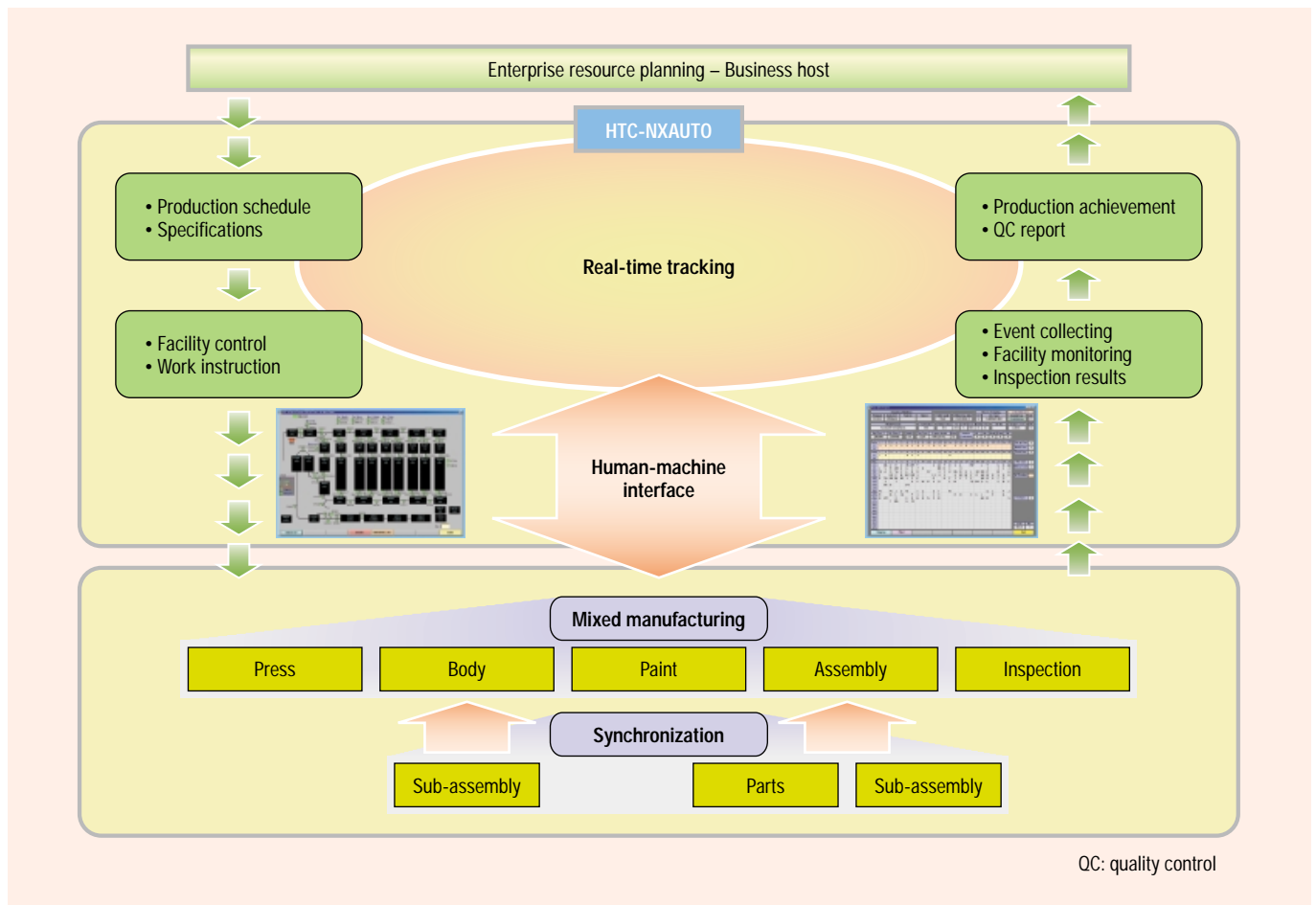

HTC-NXAUTO system configuration

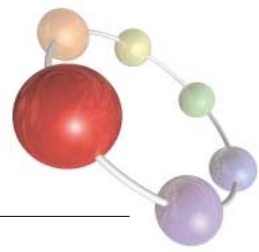

## Asia e-Learning Initiative — Development of “e-Courses” in the Non-skill-transfer Fields for e-Learning —

Asia is rich in human resources, and efficient human resources development by actively utilizing e-learning would greatly contribute to improved industrial competitiveness. To further collaboration among countries in Asia when working on a specific measure or strategy for the future development of the e-learning industry in Asia, we helped establish Asia e-Learning Network (AEN) in July 2002 among 12 Asian countries including Japan.

The implementation of this project is based on the sharable content object reference model (SCORM), which is used to build the consensus needed to ensure the interoperability of an e-learning system and its content between countries.

Hitachi worked with Keio University to implement the e-learning system recommended for the Hanoi Technical College, the Vietnam National University, the International Relation Lyceum, and the Hoa-Loc High Tech Park in Vietnam. Current e-learning is focused on

skill subjects, which can make learning details a routine. Enabling e-learning of non-skill subjects such as social science would increase the value of being connected to the network for information gathering and opinion exchange. Moreover, if we can achieve global co-development of educational materials in addition to global information gathering and opinion exchange, the value of adopting e-learning will further increase.

Given this situation, we have investigated the feasibility of adding social science and human science subjects, the issues to be addressed, the feasibility of globally co-developing materials, and the areas to be improved in e-learning systems based on the SCORM. Vietnam's participating organizations have shown a great interest in these efforts, and are eager to contribute.

We will now undertake development of courses for non-skill subjects and begin global promotion of e-learning system content.

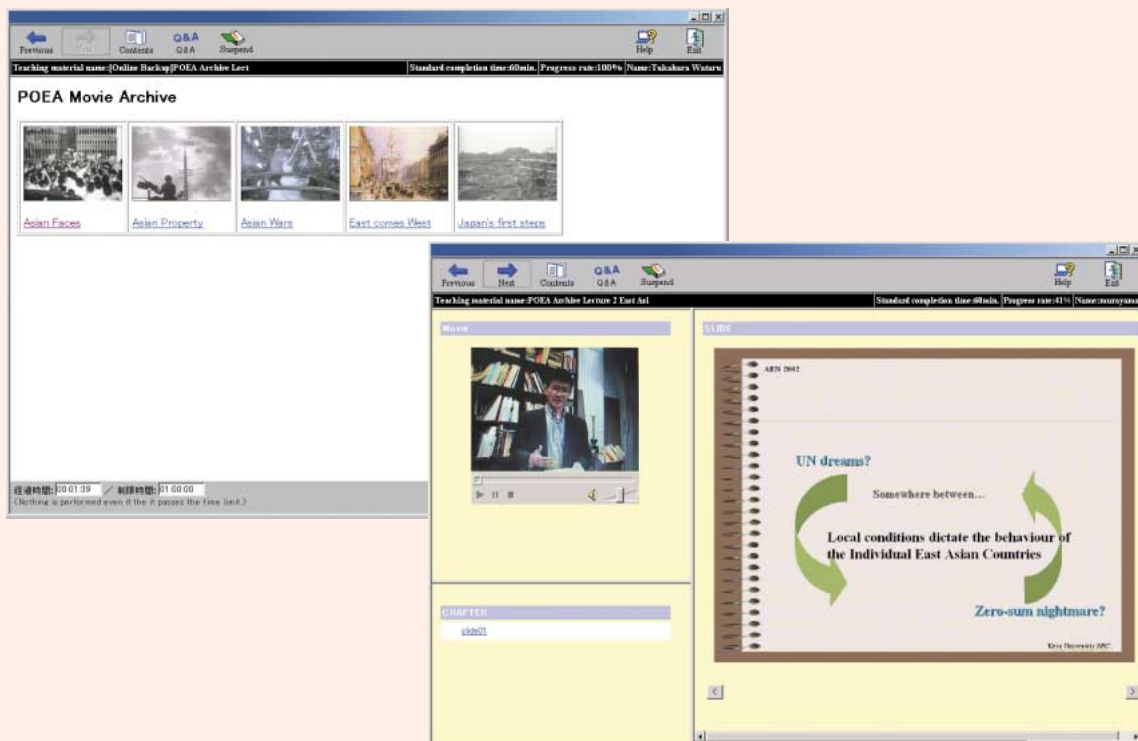

Client screen images (lecture content/learning materials)

## Asia e-Learning Initiative — Experiment in Asynchronous Distance Learning Developed with the Materials of Synchronous Lectures —

This experiment, as part of the Asia e-Learning Initiative sponsored by the Ministry of Economy, Trade and Industry of Japan, was conducted from May 2002 to February 2003 by the Tokyo Institute of Technology, the Asian Institute of Technology (AIT), and King Mongkut's Institute of Technology Ladkrabang (KMITL) in Thailand. The object was to test the practicability of the sharable content object reference model (SCORM).

The Tokyo Institute of Technology signed an Agreement of Academic Cooperation with National Science and Technology Development Agency (NSTDA) of Thailand in September 2001 and has since been providing international graduate programs in English in the form of synchronous distance courseware to the Thailand Graduate Institute of Science and Technology (TGIST) using a satellite communication system. The figure right illustrates the relationships of the Tokyo Institute of Technology, NSTDA, AIT, KMITL, and TGIST.

The experiment was conducted using asynchronous distance learning courseware for four lectures and HIPLUS on Web, a product of Hitachi Electronics Services Co., Ltd. It was designed to test (1) the efficiency of a method for automatically developing asynchronous learning contents, (2) the practicability and extensional needs of SCORM data, and (3) the effectiveness of mentoring with asynchronous learning.

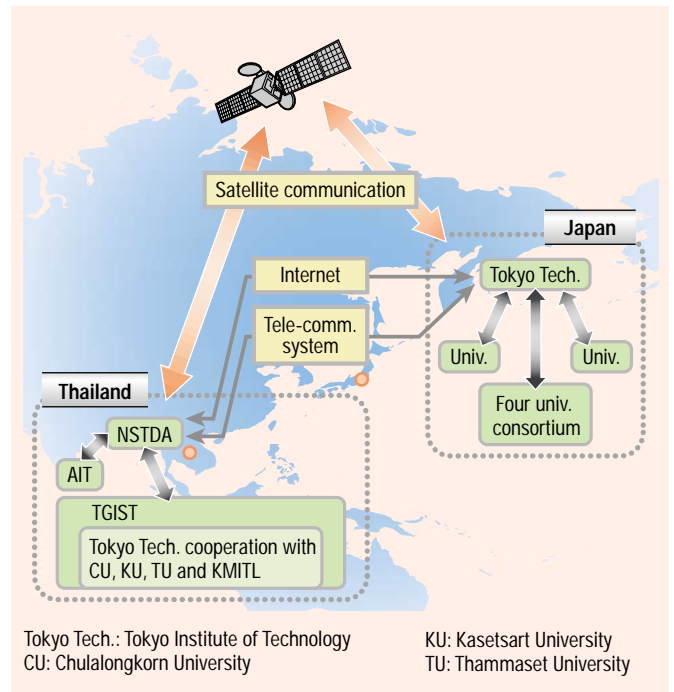

Synchronous lectures using a satellite communication system

## Solutions to Support University Management Using Information Technology — IT Solution for Campus —

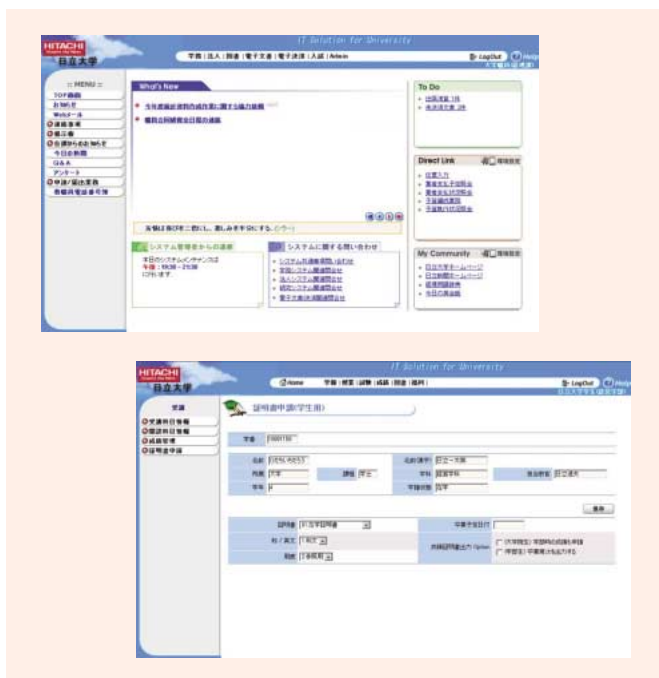

Screen images

The environment surrounding Japanese universities is changing quickly. The number of children in the population is falling and so is the number of university applicants. In addition, the government is promoting a university reform strategy called "e-Japan." A more strategic system that places greater importance on management is needed to improve the international competitive power of education.

We have developed a school-management information system solution that uses a web system as the base technology for all of the operation systems, which facilitates cooperation with existing intramural systems, reduces the cost of system integration, and improves the convenience of campus users. Using a Web browser, users can apply for entrance, register for classes, and refer to information, such as student details, credits, and grades, using a variety of equipment built on a university foundation corresponding to the ubiquitous computing society. Furthermore, making a database of the information used as a management-index will help decision-makers manage and operate the university by the management layer.

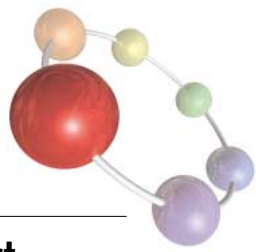

## Integrated System Management Software to Support Information Systems in the Broadband Era: Job Management Partner 1 Version 6i Advanced Edition

As information technology has continued to develop and spread, business has experienced rapid growth, resulting in a steady increase in the dependence on information systems. Also, slower networks are quickly being replaced by broadband networks, bringing important changes to the business environment. In this environment, information systems are expected to be stable and up-and-running 24 hours a day, 365 days a year, be fully equipped to handle the threat of security breaches and to be able to optimize the total cost of ownership. To aid in the construction of such corporate information systems, Hitachi has created "Job Management Partner 1 Version 6i Advanced Edition."

Job Management Partner 1 Version 6i Advanced Edition aims to ensure even higher quality by paying special attention to three concepts — service ability, service security and service cost — thus strengthening not only the information systems of organizations, but also the high-powered operation and management services of data centers, and management service providers. Job Management Partner 1 provides:

(1) Availability management that helps to maintain the stability of

servers, applications, etc. in multi-platform environments;

(2) Service management with a high level of service quality made possible by reinforcing systems based on a system's users and accurately planning the architecture of facilities, and that performs prompt and rapid analyses of the numerous factors affecting a Web system;

(3) Integrated security management that supports efficient and consistent operation of many kinds of security tools, with a special focus on de facto standard products;

(4) Storage management that enables efficient, unified management by making extensive use of the powerful functions of Hitachi's disk array subsystem.

In the near future, it is anticipated that outsourcing of information systems will increase, that the trend of converting information systems into utility computing environments will continue to progress, and that information systems will likely experience a paradigm shift towards ubiquitous environments. Job Management Partner 1 is able to respond flexibly and rapidly to these environmental changes.

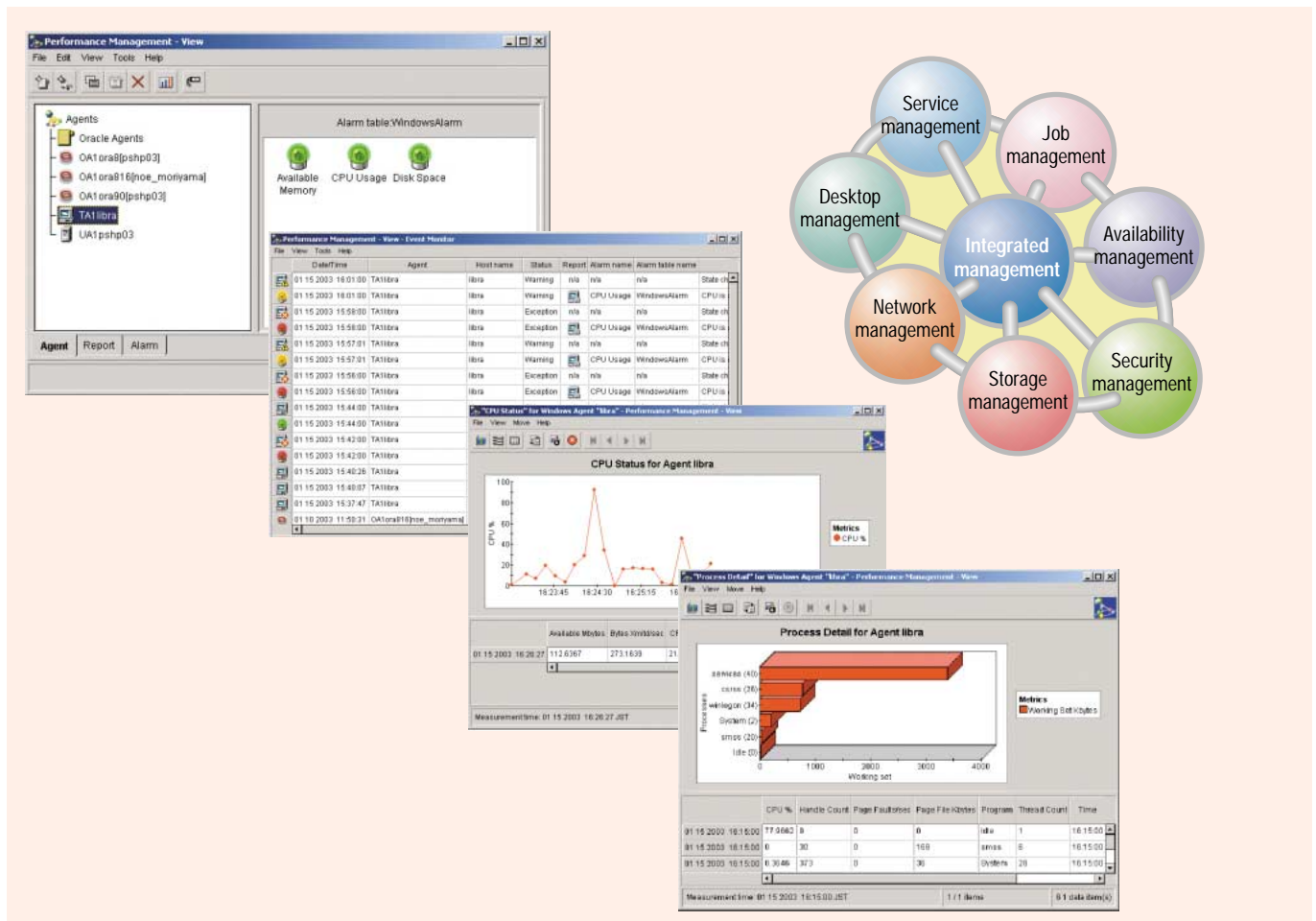

GUI of Job Management Partner 1 Version 6i Advanced Edition and its solution (upper right)

# Collaborative E-Business Platform: Hitachi Application Server Version 5

Today, networks are changing business styles, making it easier for enterprises to cooperate (collaboration). Hitachi's Web services platform enables people to access various applications on the network by using a standard communication protocol, such as the hypertext transfer protocol. This new network-business called collaborative e-business, which integrates mission-critical businesses, needs a tough and developable system. The system must be tough enough to respond to sudden load increases accompanying the spread of broadband and easy enough to change to keep up with quick changes in business style. Hitachi application server<sup>†</sup> version 5 meets both requirements and thus supports collaborative e-business.

The goal of the Web services platform is seamless collaboration of internal/external business processes, i.e. the achievement of collaboration among enterprises, organizations, and people by integrating various systems flexibly so as to maximize enterprise value.

The Hitachi application server and its family of products provide three facilities for achieving this goal:

- (1) A portal facility to collect information both in and out of the office and to supply it;
- (2) A business integration facility to seamlessly integrate in-house business with inter-enterprise transactions;

- (3) A component development facility to build various business systems quickly.

Hitachi application server version 5 has evolved dramatically under the slogan "Tough & Speedy." It applies Web and Java\* technologies to mission-critical business systems, resulting nonstop service, and supports new technologies, including Web services. As a result, the Hitachi application server

- (a) can be integrated with "OpenTP1," which is a distributed transaction processing facility for mission-critical enterprise business systems,
- (b) enhances reliability by supporting clustering,
- (c) supports advanced Web services, and
- (d) facilitates application development using expanded business-oriented Web application development tools and business solution packages.

The Hitachi application server is already being used in various Web systems and is becoming a standard platform supporting e-business. It will likely become a platform for the new information society.

\* See "Trademarks" on page 87.

<sup>†</sup> Hitachi application server is called "Cosminexus" in Japan.

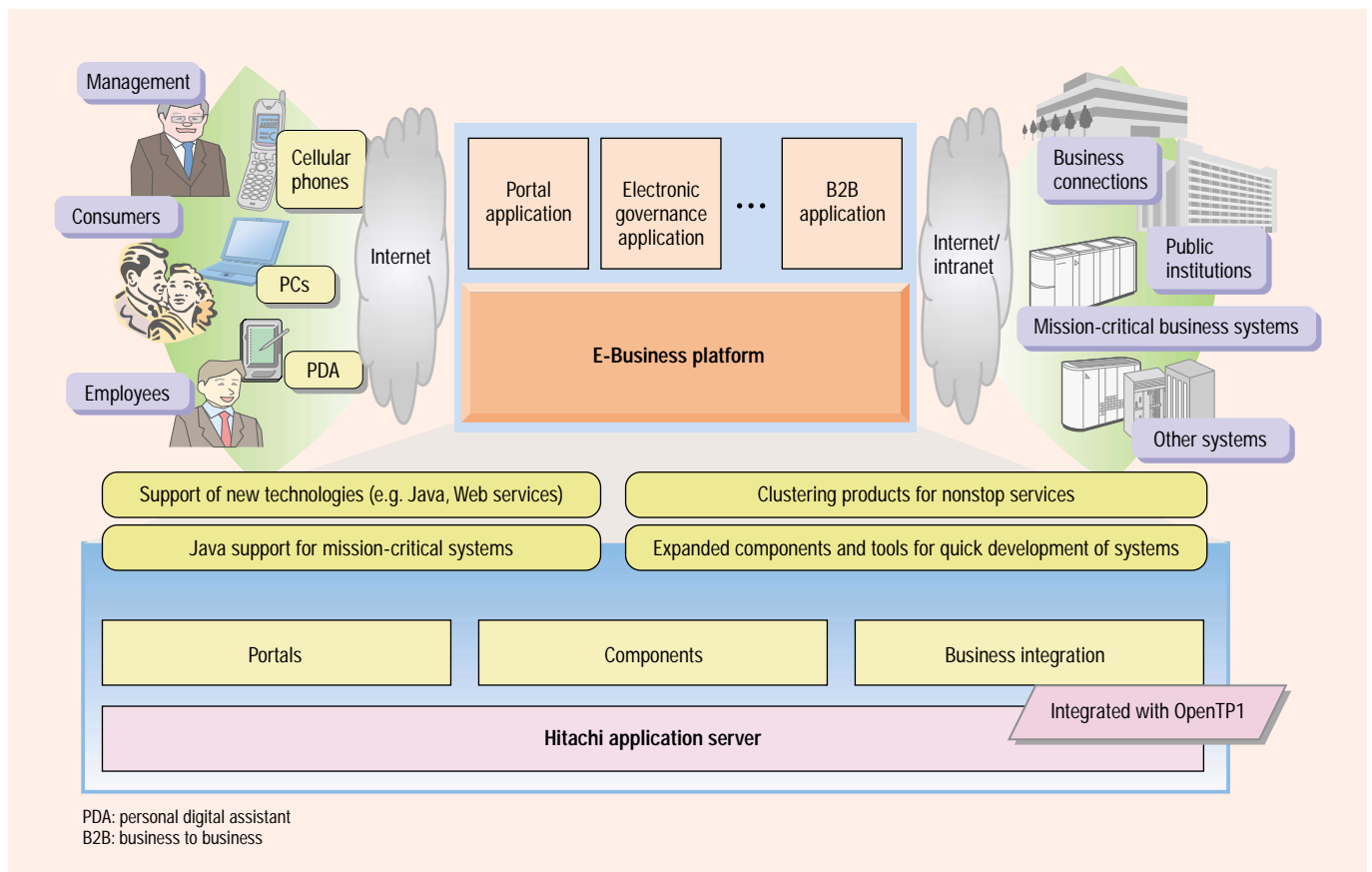

Hitachi application server  
Integration of Hitachi application server with OpenTP1 increases developability using expanded business-oriented Web application development tools and business solution packages.

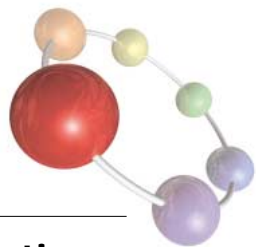

## HiRDB Version 6 (06-02): Very Basis of IT for Integrating and Sharing Scattered Data Instantly

In many companies, different types of databases may have been built for different tasks or departments. As a result, different kinds of information in these companies may be managed by different database management systems (DBMSs). Therefore, management resources can be used more efficiently by integrating the data in these different systems.

By incorporating HiRDB External Data Access, a HiRDB Version 6 product, an external database table managed by a different DBMS to HiRDB can be mapped, enabling it to be viewed as a HiRDB table for easy reference.

HiRDB External Data Access enables one to reference data in tables managed by different DBMSs, such as HiRDB, DB2\*, and ORACLE\*, from one view in HiRDB.

Unlike the conventional approach of retaining the results of extraction from each DBMS, each query pulls data from the source DBMS, so reference to the latest information is possible.

In addition, the system provides a low-cost solution for quickly integrating data types, character codes, metadata, or terms.

\* See "Trademarks" on page 87.

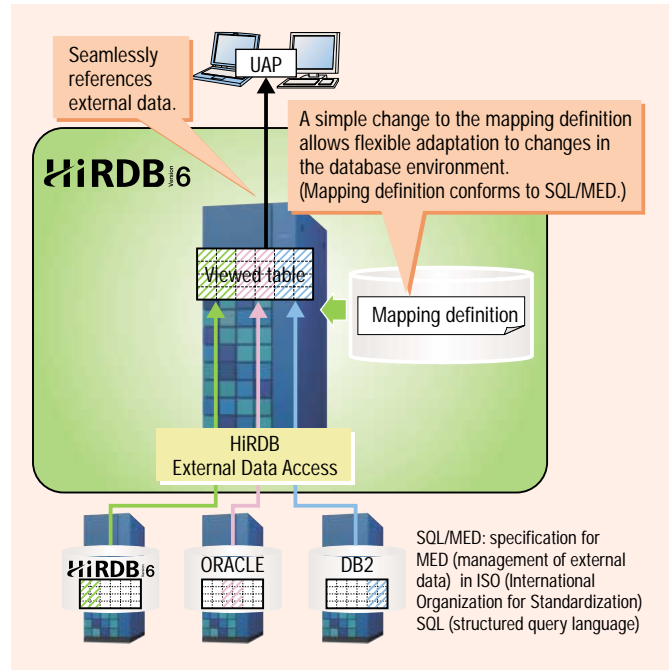

Solution provided by HiRDB External Data Access

## Versatile and High-capacity Cash-recycling ATM for Chinese Banking System



Hitachi has developed a versatile, high-capacity, cash-recycling ATM (automated teller machine), the HT-2845A, for the Chinese banking system that offers passbook printing and a multi-media function. Various installation options are available, such as installing through a wall or on a lobby floor, due to the use of a space-saving technology — a cash-recycling module with high-capacity cassettes.

This use of high-capacity cassettes (max. 9,000 notes) enables extended operational time without servicing. The newly installed passbook printing module enables transactions to be printed in passbooks. A functional combination of banking transactions and multi-media capability is implemented; the ATM is equipped with a 15-inch LCD, a function key pad, a touch panel, and Web-enabled software. The multi-media capability enables ticket selling on the Web and operation guidance.

Versatile high-capacity cash-recycling HT-2845A ATM for Chinese banking systems supports cash depositing and withdrawing, passbook printing, and multi-media Kiosk functions.



## Development of Enterprise Disk Array Series, Offering Large-scale Storage Consolidation and Seamless Storage Solutions

Hitachi's enterprise disk array series, which delivers world-class performance, scalability, heterogeneous network connectivity, high reliability, and high availability, provides various functions supporting efficient operation and management. Working with storage management software, Hitachi's enterprise disk array series simplifies and automates storage operation and management based on Hitachi's True North storage concept.

The enterprise disk array series provides such hardware functions as "ShadowImage" and "TrueCopy" within the subsystem. It enables storage operation and management integrated with databases and application systems by linking with Hitachi's storage management software.

The enterprise disk array series uses Open API (application programming interface) and an industry-standard common interface model. This API strengthens its linkage with other vendors' products, contributes to interface standardization, and supports effective

utilization of customer resources. In addition to supporting mainframes and storage area networks (SAN), support of IP networks is planned, thereby giving the enterprise disk array series the capability to handle a wide range of future storage network environments.

The main features are as follows:

- (1) By increasing the maximum number of hard disk drives within the subsystem to 1,024, double that in the previous generation enterprise disk array series, scalability of up to 147 Tbyte is possible.
- (2) By increasing the hardware internal bandwidth to twice that of the previous generation, transaction and batch-processing performances are enhanced more than 3 and 2.5 times, respectively.
- (3) Advanced functions are supported on the disk array controller. They include storage pooling, which enables flexible logic-unit assignment to servers, remote copy, which doubles the performance of the previous generation, and device management software, which enables simple operation via a Web browser.

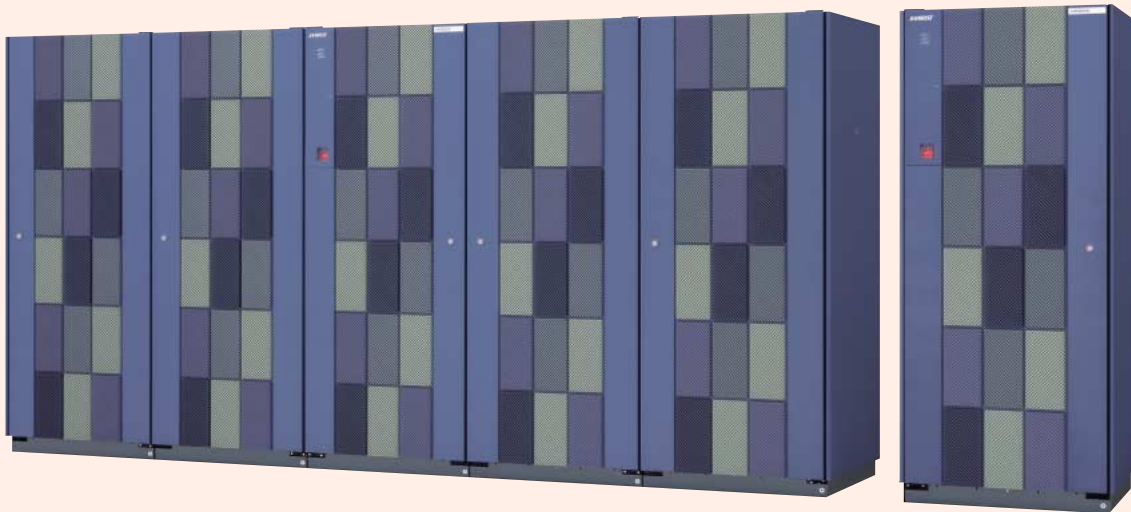

Hitachi's enterprise disk array series, offering large-scale and seamless storage consolidation

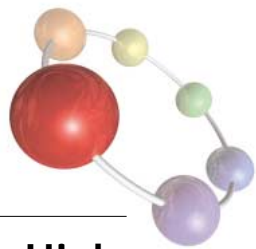

## Development of Modular Disk Array Series, Offering High Performance with Minimum Space Consumption

As storage area networks penetrate into the midrange market, the need for small-to-medium scale storage consolidation is rising. To meet this need, Hitachi has developed the new modular disk array series, designed to be the most space-utilizing hardware in its class of high-performance disk arrays.

Linked with Hitachi's storage management software, the new disk array series reduces the total cost of ownership by simplifying and automating storage operation and management. Compact 3U enclosures are used, and the total subsystem capacity can be scaled up to 32 Tbyte. Use of multiple controller-inclusive enclosures results in additional performance improvements. Thus, models that meet user needs can be provided.

The modular disk array series uses Hitachi's original functions that support seamless storage environments. These functions include storage pooling, disaster recovery and backup. Limited configuration models for entry class usage are included in the product lineup. Together with the enterprise disk array series for higher applications, this new modular series strongly supports the realization of Hitachi's storage concept "True North."



Rack-mount model (left) and floor model (right) of Hitachi's disk array series enabling high density implementation

## High-performance Reliable Servers Powered by Itanium\* Processor Family: HA8500 Series



High-performance reliable servers powered by Itanium processor family: HA8500 series

Hitachi offers a high-performance reliable server, the "HA8500 Series" based on Itanium processor family architecture, which is expected to become the world standard in business. The HA8500 Series incorporates many architectural ideas to achieve superior performance, so it is an excellent system in the price-performance ratio.

To meet the various customer's needs, multiple OSes (HP-UX\*, Windows, and Linux\*) are supported in the HA8500 Series, and the OS most suitable for the application can be chosen.

The multiple logical processor feature (MLPF) of the HA8500 Series provides customers with a flexible system. One physical server can be virtually used as multiple servers by the MLPF logical partitioning function.

Furthermore, high performance and high reliability are provided by the Hitachi chipset. Hitachi brings mainframe technology to this chipset and combines this chipset with the advanced capabilities of the Itanium processor family.

The Hitachi HA8500 Series servers have industry-leading performance and reliability.

\* See "Trademarks" on page 87.

## Enterprise UNIX Server Series

The Enterprise Server 630 has been added to the lineup of Enterprise UNIX<sup>®</sup> Servers, which use the AIX<sup>®</sup> operating system (OS) and were designed for the mission-critical marketplace. The 630 is the first server product developed by Hitachi that will be manufactured under the strategic alliance agreement with IBM<sup>®</sup>.

The 630 can support up to four POWER4+<sup>®</sup> processors with clock rates of 1.45 GHz, thereby achieving high performance. The application of Hitachi's world-leading high-density packaging technology is one of the factors that make the 630 more compact and provide customers with better price-performance. The 630 provides higher reliability, availability, and serviceability due to the use of highly reliable design technology that Hitachi has acquired through its main-frame development activities over many years.

In addition, a newly developed software feature enables high-speed switchover for hot-standby systems running Hitachi's database management system and high-availability software. This shortens switchover latency from several 10 seconds to nearly 10 seconds. Newly developed software notifies the standby system of an OS down of the current system directory via a designated path and instructs it to restart the operation immediately. This enables immediate switchover of the shared disks from the current system to the standby system.

Hitachi's Enterprise UNIX Server meets a broad range of users needs, from Internet servers to large-scale database systems or to on-line transaction processing systems.

\* See "Trademarks" on page 87.

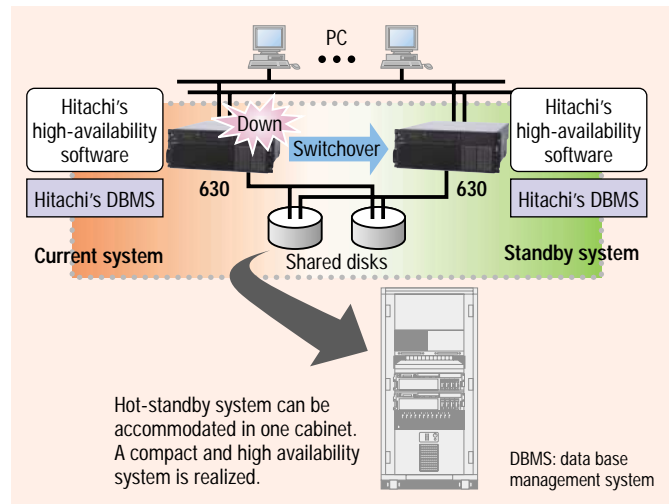

Example of hot-standby system configuration using rack-mounted 630 model 6C4

## New Generation Enterprise Server

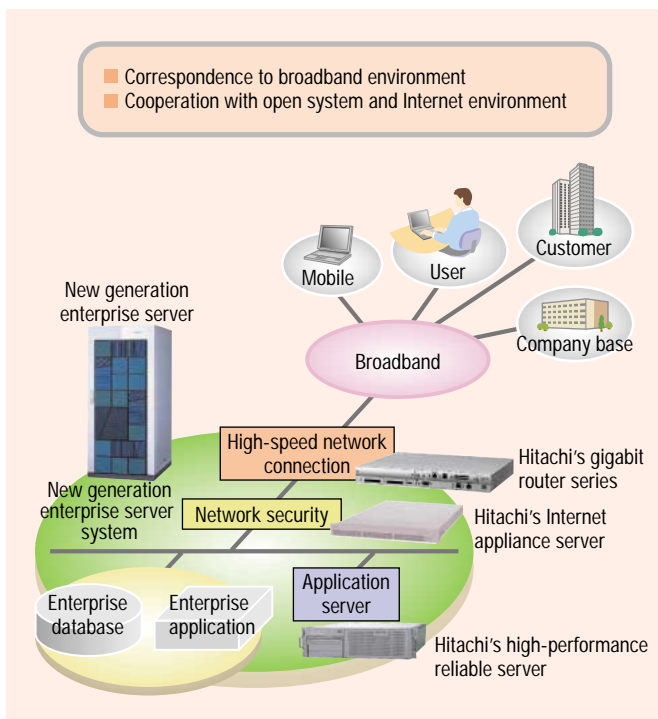

New generation enterprise server series supporting an informational lifeline

The new generation enterprise server for Hitachi's proprietary operating systems has the high reliability and high availability needed for mission-critical systems in the broadband age.

This enterprise server supports an internal disk sub-system that provides high performance and high reliability. In addition, a redundant power supply configuration and cooling fan are used to provide the high reliability necessary for mission-critical work. This enables switching to an alternate component whenever a fault occurs so that mission-critical work can continue without disruption.

Moreover, it is a rack-mounted server that can be installed in a 19-inch standard rack, together with Hitachi's gigabit router and Hitachi's high-performance reliable servers. This all-in-one rack system is suitable for use on an Internet open-system platform.

This server uses the POWER processor as an instruction processor; this processor supports Hitachi's proprietary operating systems using emulation technology developed by Hitachi.

Use of partitioning technology enables provision of a hybrid system in which Hitachi's proprietary system and the UNIX system work together. This enterprise server enables cooperation and integration between an open system and Hitachi's proprietary system inheriting Hitachi's proprietary program property, which users have already had.

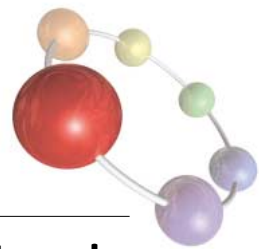

## Compact, High-performance Gigabit Routers for Enterprise and Branch Offices

Hitachi has added two new compact, high-performance routers for broadband services to its lineup of gigabit routers. These 1U (one unit = 44.45 mm)-size models are low-end models in Hitachi's lineup of gigabit routers, which are deployed worldwide. Inheriting the hardware architecture and software of the current gigabit routers, these models offer the same superior performance, reliability, and functionality in a smaller size.

The new models provide high-speed throughput of up to 1 Mpps (1 million packets per second). They are equipped with an on-board integrated 10/100 Ethernet interface with two or four ports, and one or two expansion slots supporting such interfaces as Gigabit Ethernet and ATM OC-3.

The new models are suitable platforms for enterprise and branch offices using broadband services, such as IP-VPN and wide-area Ethernet, provided by carriers.

The key features of the new models are as follows:

(1) High performance

Using advanced hardware-based routing, the new models achieve high-performance IP routing for broadband services. They support quality of service (QoS) control, such as packet prioritization and

bandwidth guarantees, using their purpose-built hardware. Therefore, the customers can easily manage network traffic and services, with no degradation in system performance.

Filtering and IPv4/IPv6 multicasting are also supported. These models can be used to construct low-delay high-speed networks.

(2) Compact size

The new models with hardware-based process are compact enough to fit into a 1U-size rack in a cabinet and offer high-performance routing in a limited space.

(3) IPv6 (Internet Protocol version 6)

The new models achieve high-performance IPv6 routing using hardware-based processes as well as IPv4 routing.

These model have functions that support migration to IPv6, such as IPv4/IPv6 dual-stack and IPv4-over-IPv6/IPv6-over-IPv4 tunneling. IPv4/IPv6 dual-stack allows IPv4 (Internet Protocol version 4) and IPv6 networks to run simultaneously within the same box and IPv4-over-IPv6 (IPv6-over-IPv4) connects IPv6 (IPv4) LANs (local area network) with IPv4 (IPv6) network. Customers can thus migrate from IPv4 to IPv6 smoothly and seamlessly.



Two new models for enterprise and branch office deployment



Hitachi's gigabit router lineup

Two new models for enterprise and branch office deployment (top) and current gigabit routers series

## IPv6-compatible Broadband Access Gateway with 1U-height

With the spread of broadband Internet access through such means as ADSL, CATV, and FTTH, Internet users are increasingly demanding connection at speeds greater than 1 Mbit/s. There is now a strong demand for network-access equipment that operates according to a high-speed Internet-processing protocol to provide flexible support for these access methods along with high data-transfer rates.

Our new broadband access gateway is a very compact and high-performance access gateway that supports both IPv4 and IPv6. In addition, it achieves high throughput by using a network processor for packet processing. There are two models: the broadband access server and an address translator.

By effectively applying the broadband access server and the address translator, telecommunication carriers, enterprises, and the

like can improve their network architectures. These devices are compact and powerful, so they help the user to use more effectively physical space. They also facilitate the control of broadband service quality and the maintenance of a network environment in which IPv4 and IPv6 coexist. The latter feature is particularly helpful to users intend to create new services.

This new small model is an ideal choice for cost-effective IPv4/IPv6 access gateway networks. This ultra-dense, high-performance access gateway for network infrastructures is designed to increase availability and lower costs. It has a space-saving 1U (44.45 mm) rack-optimized chassis. The access gateway is designed for maximum uptime in telecom, enterprise, and service provider environments.

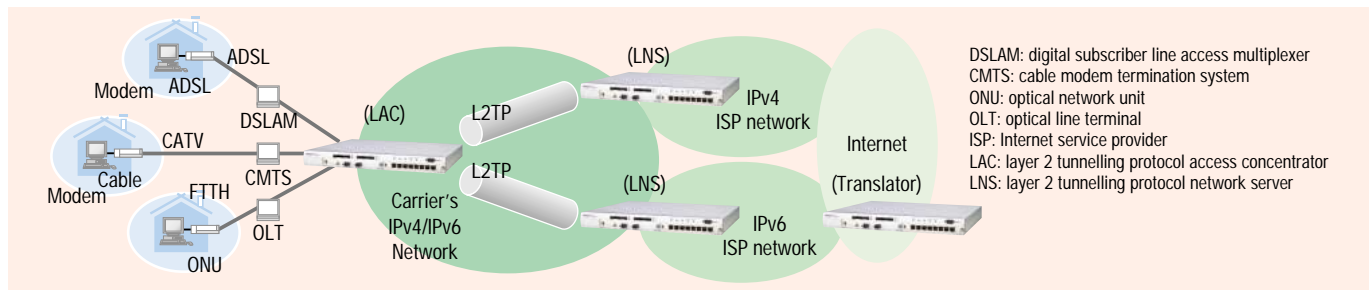

Example configuration of a broadband access network application using the broadband access server and address translator. The server accommodates various types of broadband-access lines, such as ADSL, CATV, and FTTH. The translator bidirectionally interconnects IPv4 and IPv6 networks.

## PON-based Gigabit Ethernet System for Broadband Access Network

Broadband networks have been spreading widely in response to escalating requirements for higher capacity traffic and are now being used in various areas as exemplified by video streaming ser-

vices and by the application of wide-area LAN services to intranet-networks connecting the distant branches of an enterprise.

Development of an economical broadband infrastructure with higher capacity requires access lines with speeds greater than that of current 100-Mbit/s systems.

Hitachi has focused on broadband access systems and is developing a gigabit passive optical network (PON) system that complies with IEEE 802.3ah.

It has the following several important features.

- (1) It complies with the IEEE 802.3ah international standard.
- (2) The PON interface at the optical line terminal (OLT) in the central office can accommodate up to 64 users enabling investment cost to be reduced.
- (3) It has the dynamic bandwidth assignment (DBA) technique. The DBA technique uses statistical multiplexing to ensure a minimum user bandwidth and to effectively utilize any unused bandwidth dynamically.
- (4) It provides a Layer 2 switching function, which enables flexible network design independent of the upper layer protocols.

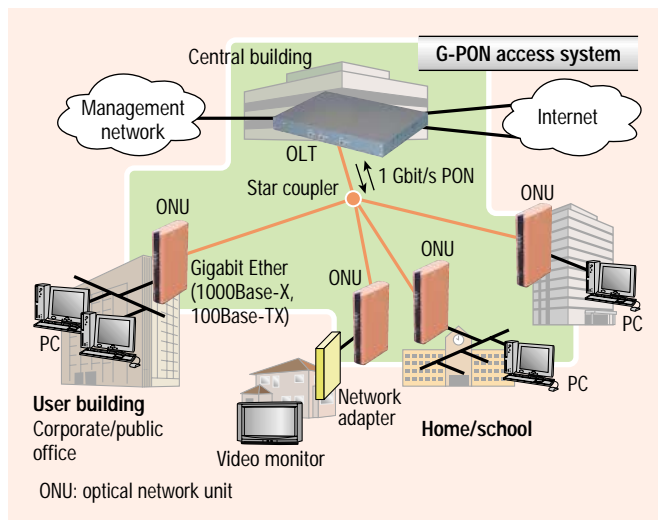

Gigabit PON access system

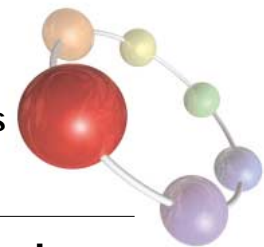

## Large-capacity DWDM System Supporting Broadband Optical Networks

The AMN6100/7100 Dense Wavelength Division Multiplexer (DWDM) system supports up to 16, 32, 64, and 128 wavelengths (expandable to a maximum of 128 channels) in the C- and L-bands. The DWDM system provides an open interface that supports many types of client traffic, i.e. any combination of STM-64/OC-192, STM-16/OC-48, STM-4/OC-12, 10GbE (10-gigabit Ethernet) and GbE is possible.

The AMN6100 consists of an end terminal (ET), a line amplifier (LA), and an optical add/drop multiplexer (OADM). The maximum transmission distance without regenerators is around 1,040 km (80 km x 13 spans). The AMN6100 OADM enables the DWDM system to add/drop wavelength channels at intermediate sites between ET sites. The AMN6100 can be used with conventional single-mode fiber (SMF: G.652), dispersion-shifted fiber (DSF: G.653), and non-zero dispersion shifted fiber (NZDSF: G655), and any combination of these optical fibers.

The AMN7100 (lambda terminal) consists of transponder cards for the various tributary signals of STM-64/OC-192, STM-16/OC-48, 10GbE and GbE, and of multiplexer cards with the multiplexing functionality of four STM-16/OC-48s or STM-4/OC-12s and of two GbEs. The multiplexer cards operate as tributary multiplexers for the DWDM equipment, thus achieving more efficient use of the lambda resources in a fiber. These cards provide a transparent transport function, transferring tributary overheads, such as for automatic protection switches, order wires and data communication channels, without modification through the 10.7-Gbit/s backbone

network. Optionally, an optical selector card is used to enhance system reliability by providing a 1+1 optical path protection function.

An ITU-T G.709 compliant OTN (optical transport network) overhead-processing function is used for DWDM network operation, administration and maintenance (OAM). A Telcordia GR-253-CORE and ITU-T G.707 compliant SONET/SDH overhead-monitoring function is used for the tributary signals. The transparent transport function is accomplished by transmitting the overhead of the tributary signals. Tributary-network providers are able to use this feature to transfer their own OAM via Hitachi's DWDM network.

The transmission capability has been improved (additional 6-dB gain for the optical signal-to-noise ratio) by adding a powerful FEC (forward error correction) function: 8-byte correction based on a Reed-Solomon code.

The AMN6100/7100 DWDM system has been awarded contracts from large carriers in the U.S. and Japan. Particularly in North America, the system has been used in commercial networks with over 20,000 km of network.

The AMN601A (DWDM) or AMN601GF (CWDM: coarse WDM) is an attractive and economical solution for metro/access/enterprise network applications. The AMN601A and AMN601GF support up to 32 and 12 wavelengths per fiber, respectively. They provide various interfaces, such as STM-16/OC-48, STM-4/OC-12, STM1-/OC-3, GbE, FC (fibre channel), FICON (fiber connection), and ESCON (enterprise system connection).

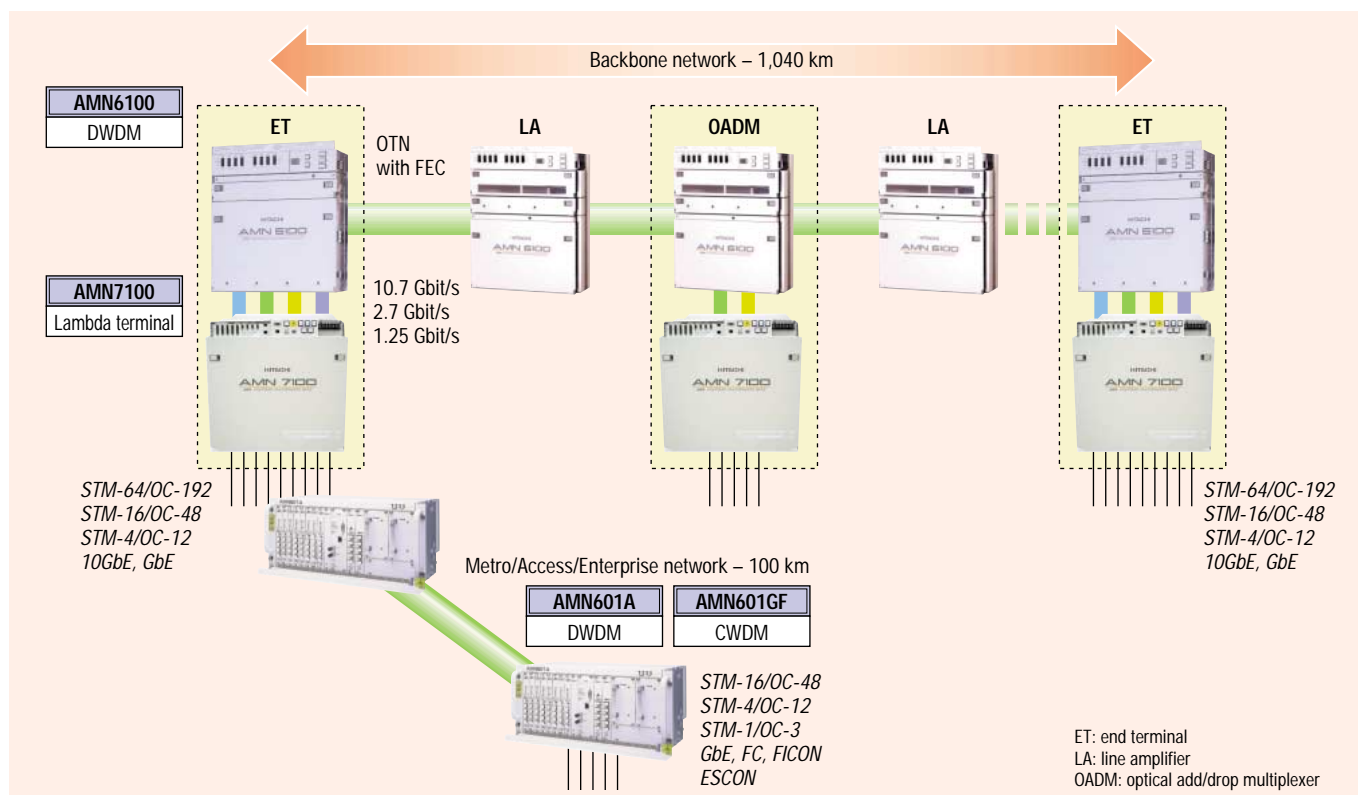

DWDM backbone and metro/access/enterprise network with AMN6100/7100 and AMN601A/601GF

## 1xEV-DO Overseas Model Base Station for IMT-2000 Band

Hitachi has developed the 1xEV-DO (1x evolution-data only) Base Station for the IMT-2000 (International Mobile Telecommunications 2000) Band. IMT-2000 has been approved by the International Telecommunication Union (ITU) as the third-generation (3G) wireless communication system.

One of the main features of the base station is its compact size (requires a floor space of only 300 × 400 mm). This is a significant reduction in the space required. To reduce cable loss, an optical interface is placed between each base station and high-power amplifiers which are installed near the antenna and are directly connected to it. Since the base station uses the universal IMT-2000 frequency band, seamless and fast mobile packet communications is possible on a global scale.

Hitachi has also developed a 1xEV-DO system that enables carriers of existing CDMA 1x services using a frequency band of 800 MHz to provide faster mobile data communication services.



1xEV-DO overseas model base station for IMT-2000 band (left) and high-power amplifiers

## PHS Cell Station

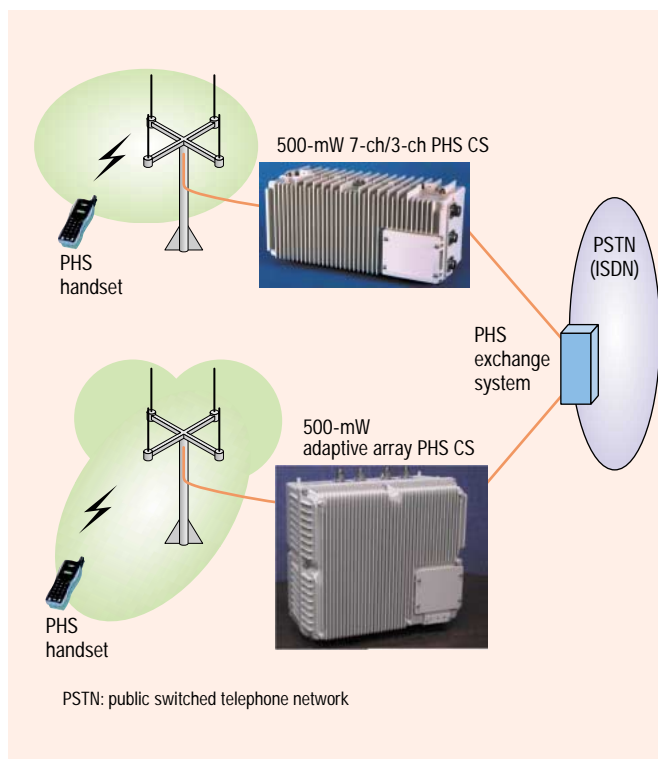

The Personal Handy-phone System, or PHS, originated in Japan, is a local wireless communication system. PHS features high-quality voice and data transmission up to 64 kbit/s. The PHS market in China is rapidly growing, and the number of subscribers exceeded ten million at the end of 2002. Hitachi has been supplying this market with PHS cell stations (CSs) since 2000. The total number of units shipped has reached tens of thousands, and they have been deployed in cities in China.

The PHS CS is connected to an Integrated Services Digital Network (ISDN) and communicates with PHS handsets using 1.9-GHz radio waves. To multiplex several voice channels, such as 3, 7, or 15 channels, time division multiple access (TDMA) is used. Hitachi's main products are 500-mW-output PHS CSs handling 3 or 7 channels. In addition, Hitachi has developed an adaptive array antenna for PHS CSs handling 15 channels. It has higher wireless penetration and mobility and can handle heavier traffic loads, enabling it to cover a wider area than by Hitachi's original adaptive array control method.

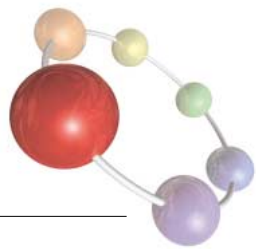

## 10-Gbit/s Optical Transceiver Modules for 80-km Transmission

We have developed a 10-Gbit/s optical transceiver module that fully complies with US Telcordia GR-253-CORE LR-2c and ITU-T G.691 L-64.2c specifications without an optical amplifier. Such modules are used in metropolitan area networks and high-speed router networks.

The transmitter part has adopted newly developed modulator integrated LD (laser diode) module that has low-chirp and high-output power characteristics; it uses an LD driver IC that has a large output amplitude and internal offset control circuits. This drastically suppresses waveform degradation even after 80-km transmission.

The receiver part uses a newly developed highly sensitive avalanche-photodiode preamplifier module that achieves sufficient receiving sensitivity to compensate for the loss resulting from 80-km transmission.

The module is 76 mm wide, 101 mm deep, and 13.9 mm high. Its alarm and monitoring features are compatible with multi-source agreement specifications.

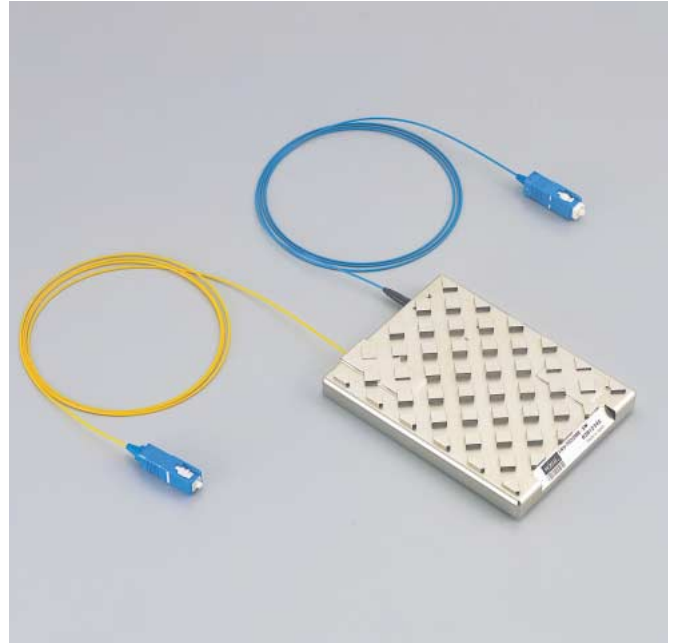

10-Gbit/s optical transceiver module for 80-km transmission

## Avalanche Photodiode Module for 10-Gbit/s Optical Communications

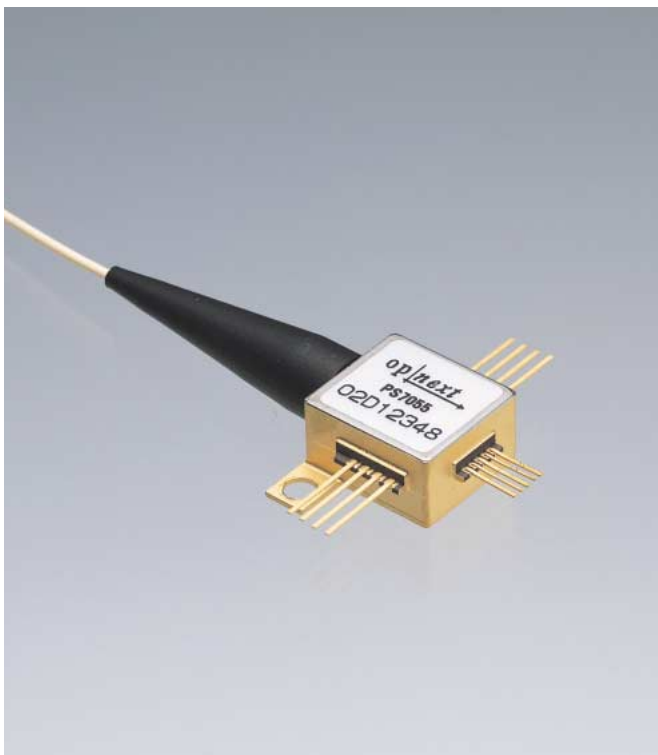

APD module for 10-Gbit/s optical transmission

High-capacity transmission systems are required for metropolitan area networks supporting high-speed wireless Internet data communication. High-performance receiver modules are needed to achieve a low-cost and simplified network architecture. We have developed an avalanche photodiode (APD) modules suitable for 10-Gbit/s transmission through 80-km fiber.

The module has a wide bandwidth and high gain APD (gain-bandwidth products: 120 GHz) with InAlAs multiplication layer, and a low noise transimpedance type preamplifier IC by using high speed SiGe heterojunction bipolar transistor process. The receiving sensitivity is  $-28$  dBm in the 1.55-micrometer wavelength region.

The APD and preamplifier IC are hermetically sealed in a 1.0-cm<sup>3</sup> package with a thermistor for monitoring the inner temperature.

## NX Series LCD Rear-projection Monitors

The NX series LCD rear-projection monitors were developed for a variety of applications including 24-hours-a-day/365-days-a-year operating mission control, command and control, and surveillance. The NX series thus makes use of many of Hitachi's advanced technologies.

Among the many factors affecting image quality, brightness and contrast are the most important ones. In the NX series high brightness and high contrast ratio are achieved simultaneously. Hitachi's optical technology is used to achieve high brightness (e.g. 1,000 cd/m<sup>2</sup> in a 50-inch monitor) using only one 100-W lamp. Use of Hitachi's black-stripe screen technology minimizes reflection of ambient light on the screen surface, resulting in a high contrast image even in bright surroundings.

A variety of technologies are used to achieve high-quality images. A four-channel digital purity adjustment function compensates for color shading within each screen, and a 10-bit digital gamma adjustment function compensates for color balance discrepancies between screens. Also use of Hitachi's thin mullion screen technology produces an almost physically seamless image across any configuration. Consequently, near seamless enlarged images with well-balanced color and brightness uniformity are produced on all screens across any configuration.



Rear-projection monitors designed for maximum visibility and reliability

## Wireless Network Projector: CP-X885



Wireless and network LCD projector: CP-X885

Hitachi has developed a wireless network LCD projector, the CP-X885. It has a number of outstanding features, including the following.

- (1) Its 3,500-lm brightness, short throw lens, and 1.5x zoom lens allow greater flexibility for use in restricted spaces, such as classrooms.
- (2) Its one-touch button enables quick keystone adjustments and input searches. Its jog dial facilitates switching of the input source and enables the selected input to be checked at a glance.
- (3) Its optional wireless network modules (IEEE802.11b) enable presentation without a PC by using a PC card. It can connect to up to four PCs without wires and project onto four screens.
- (4) When connected to a LAN, it can control and monitor multiple projectors, including on/off, input selection, and lamp and error status monitoring.

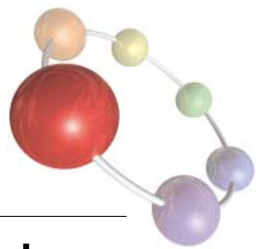

## Mobile Multimedia Communicator with Built-in Wireless LAN

The NPD-10JWL mobile multimedia communicator for corporate use is now on the market.

Main features:

- (1) Simple, palm-size, and lightweight configuration (155 g)
- (2) Simple operation through "pen touch" access and side jog dial
- (3) Easy connection to broadband networks via wireless LAN access points through built-in wireless LAN (IEEE 802.11b) and Windows CE.NET\* OS featuring high connectivity with wireless LAN
- (4) Intel PXA250 applications processor CPU enabling extensive multimedia functions such as browsing by horizontally oriented display and full-screen moving-picture playback

\* See "Trademarks" on page 87.



NPD-10JWL mobile multimedia communicator

## Portable Internet Appliance



Portable Internet appliance

The Internet's rapid and widespread diffusion has made the Internet an important tool for both corporate and individual users. In spite of the widespread use of PCs, most people would prefer to use a more user-friendly device, a system that has maybe only one or two specific purposes. Given this potential market, Hitachi introduced the webpad, the wireless tablet to the U.S. market in 2001.

The product is easy to use, has quick response, and is reliable. The third-generation model is now available. It is similar to a tablet PC, which is positioned as a sophisticated, high-value-added PC. In contrast, the webpad is positioned as a thin client for the mobility conscious, so the concepts of these two products differ greatly. The webpad supports only the functions customers really need, making the system load lighter.

The webpad is now being used in various business areas, from healthcare to hospitality and industry. Hitachi has established a new 'wireless thin client' product area to provide its customers with such solutions.