

Information Systems



Hitachi is delivering its promise to become one of the best solutions partners for its customers by developing powerful new products in the area of information systems, communication systems and multimedia tools. Accelerating IT revolution or e-Revolution, these products not only contribute to the success of our customer organizations, but also make society more convenient and comfortable for users and consumers. An example is our Job Management Partner 1 that provides integrated solutions for Internet service quality management.



Job Management Partner 1 Version 6i: Integrated Solutions for Managing the Internet Service Quality Management

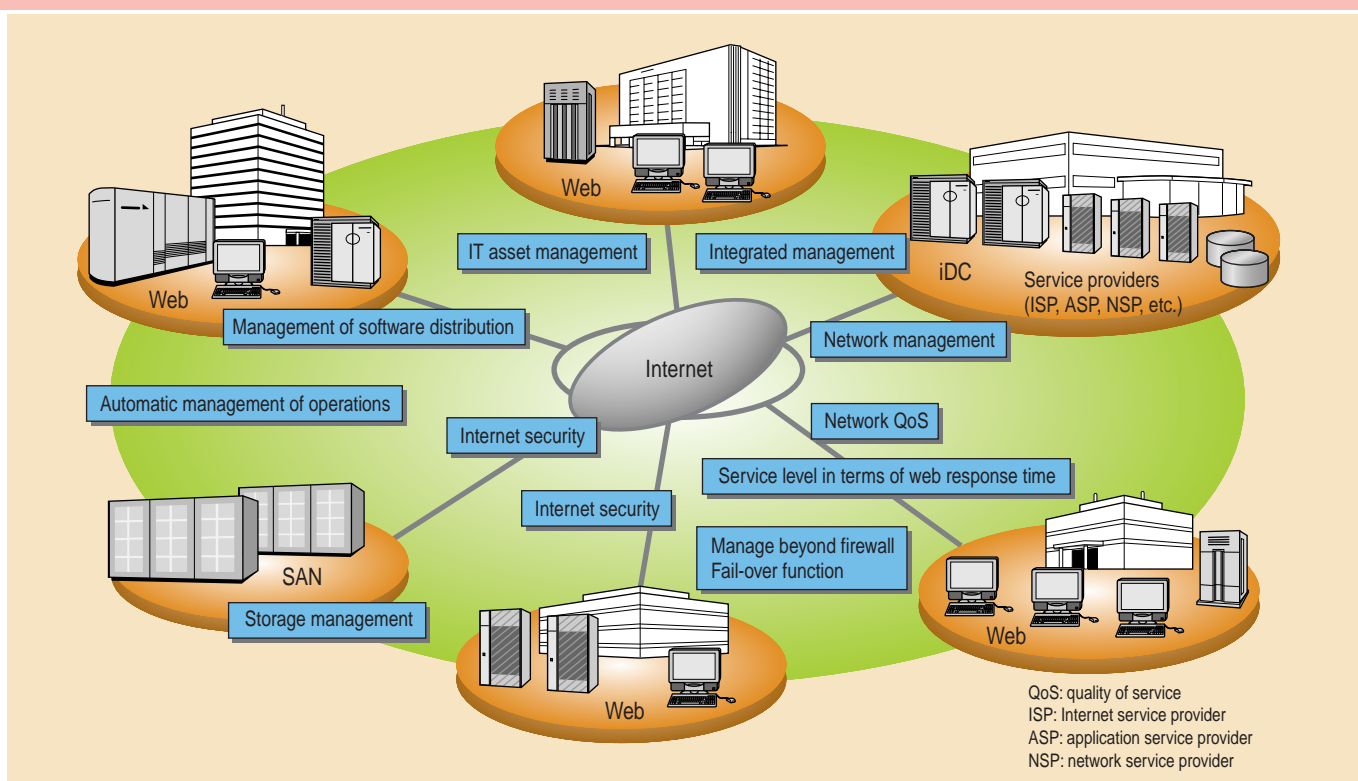

Concept of Job Management Partner 1 Version 6i

Job Management Partner 1 (JP1) solutions support management of the integrated information systems that are required by e-business. In today's highly competitive e-business market, the requirements for the operation and management of information systems are rapidly changing. In addition to support for Internet technologies that provide security and broadband delivery, the assurance of a quality of service as agreed to in a service level agreement (SLA) and improvements in the quality of system management are now being demanded. Hitachi has enhanced Job Management Partner 1 to produce Job Management Partner 1 Version 6i. The package supports the building and operation of highly reliable and secure information systems on the basis of the concept of Internet Service Quality Management that supports improvements in the quality of service delivered in an Internet environment.

JP1, currently deployed in more than 5,000 corporations, is an industry-leading software package for system management and is highly rated throughout the world. In addition, JP1 supports a wide variety of solutions that cross the lines that separate industries and businesses. These include solutions for enterprise resource planning (ERP), data warehouse (DWH) and Web-computing.

JP1 has evolved from being a job-management solution (in Version 5) to become an integrated system-management solution. Version 6 came soon after Version 5 and added support for service provider (SP) and Internet data center (iDC) environments. With Version 6i, JP1 has been further enhanced to support Internet service quality management. JP1 continues to grow as a system-management tool for new business environments.

New features of JP1 Version 6i are described below:

(1) Enhanced Service-management Functions

JP1's enhanced service management functions include:

- the collection of such performance information as web-site response time and Internet service performance so you can keep track of the system usage rate and reduce bottlenecks, and thus maintain high quality for your service on the Internet;
- reporting on tasks such as analyzing trends in their performance and verifying the degree to which an SLA is fulfilled; and
- managing Internet Protocol (IP) resources to enable the control of network bandwidth required to fulfill the SLA, as well as assigning and securing particular network bandwidths for specified Internet users, and selecting optimal routes for efficient network operations.

JP1 also provides a network-management product that assists in the building of a network address translator (NAT) environment that you can use to centrally monitor and manage multiple network environments and to simplify the building and operation of Internet-based systems.

(2) Enhanced Security-management Solutions

JP1 manages security by detecting illegal intrusions and executing protective action on the basis of a defined security policy to prevent damage or loss. This security management function even detects intrusions of the type that slip through firewalls and prevents damage, and prevents the leaking of confidential information thus improving reliability and system stability.

JP1 also controls access to protect Web pages and files against security leaks and falsification of data.

(3) Enhanced Asset-management Solution

Software-license management is provided for the central monitoring and control of software-license usage in corporate network environments. This enables you to operate and monitor the execution of predetermined numbers allowed by licenses.

Solutionmax with EAI Dramatically Reduces System Development Time

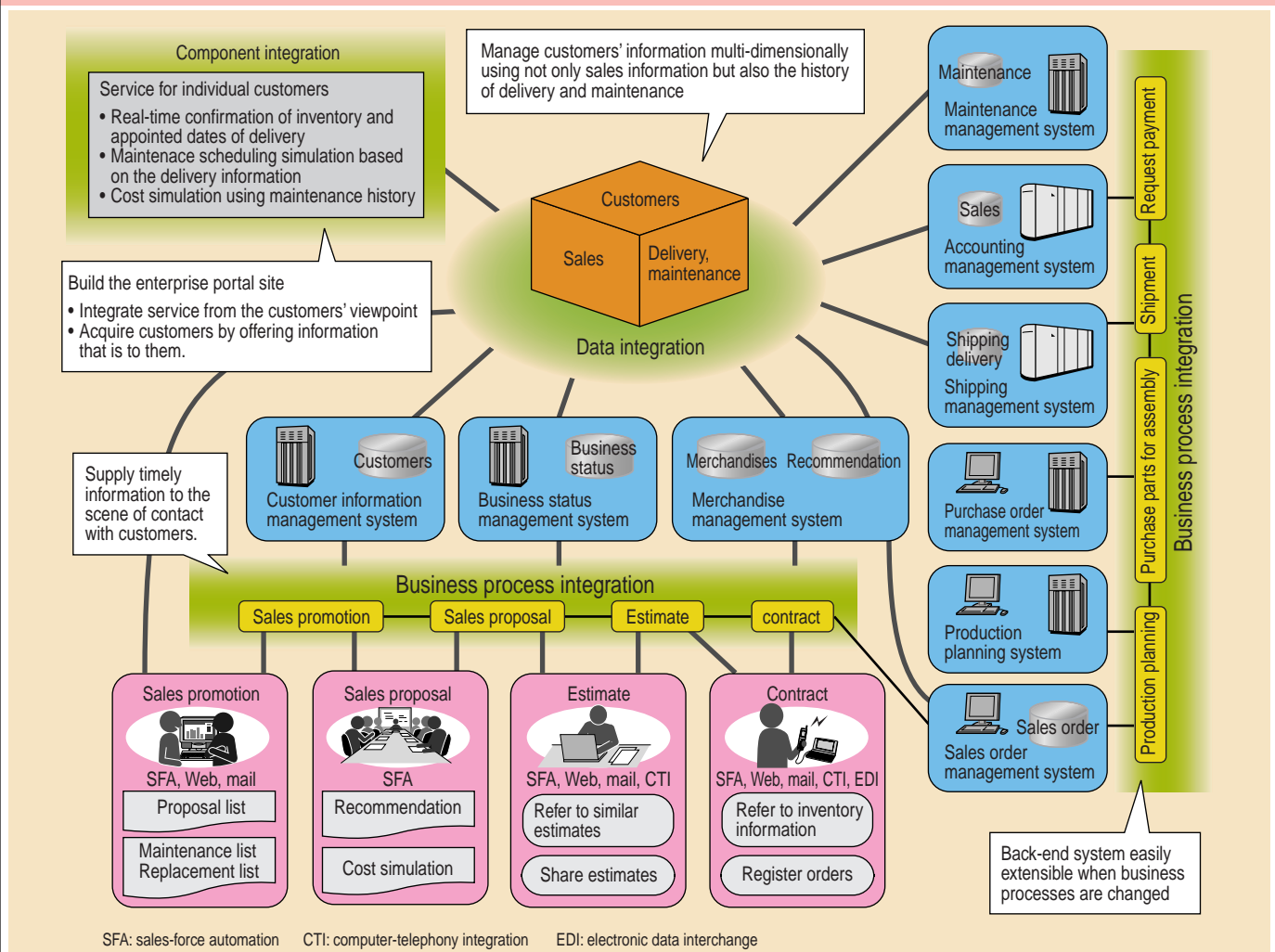

CRM solution for the manufacturing industry

Enterprise application integration (EAI) has recently been attracting attention because of its ability to build enterprise information systems in a short time and in a step-by-step manner. However, simply introducing EAI products does not have the intended effect. To achieve a dramatic effect, the EAI concept must be adopted from the system-design phase.

Solutionmax with EAI provides a complete set of services for EAI from the business-design phase to the system-implementation phase and dramatically increases system productivity. This is realized by the following processes.

- Standardizing and storing business-process templates and data-model templates
- Standardizing and storing system-design patterns
- Standardizing and storing of integrated applications
- Preparing system-integration products that are appropriate for EAI

Solutionmax with EAI is classified into three areas.

(1) Business Process Integration (BPI)

BPI uses a workflow-middleware platform to build an operational system such as a system for planning sourcing based on the standardized business-process template. The system is easy to

extend when business processes are changed to make a more effective business.

(2) Component Integration (COI)

COI uses a message-broker middleware platform to build a front-end system integrating several back-end applications by messages based on a standardized message format.

(3) Data Integration (DAI)

DAI uses a data-transformer middleware platform to build a data-warehouse system, such as a customer management system, on the basis of the standardized data-model template.

EAI can be applied to business systems of many types by combining these patterns. The CRM (customer relationship management) solution for the manufacturing industry consists of EAI in the above three areas and provides a sales portal system for customers (see the figure).

The effectiveness of the EAI is demonstrated by an example of its application to the sourcing process of a certain assembly-level manufacturer. The EAI solution reduces the manpower required for system development to about one-fourth of that required by previous methods.

Trade Finance EDI Solutions

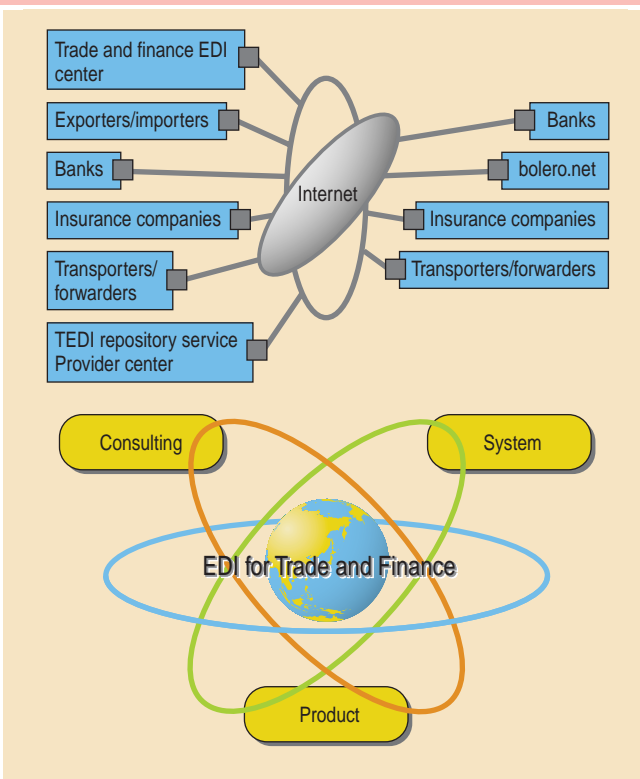

EDI solutions for trade and finance

EDI (electronic data interchange) for trade and finance is a core part of the infrastructure that connects electronic marketplaces within an industry, such as for manufacturers of automobiles, iron and steel, or electrical goods.

There are two EDI systems for trade and finance. One is an infrastructural development and accompanying on-site verification project for trade and finance EDI, named TEDI (trade EDI). This system was financed by Japan's METI (Ministry of Economy, Trade and Industry). The other is "bolero.net" which has been offering commercial services, mainly in Europe, since 1999.

Hitachi released server software named TF21 and offered related solution services in April 2001. The TF21 supports connection to "bolero.net," which is already in operation.

The TF21 consists of messaging functions, as core functions, that enable the safe transfer of trade documents through "bolero.net," and document-creating functions, as optional functions, that co-operate with application package softwares by automatically transcribing trade documents.

To provide a wider range of solutions and solution-related services, we are going to support consulting services for introducing trade finance EDI, based on our experience in applying and evaluating the system in experimental trials among Hitachi group companies. We will also support system integration services, ranging from stand-alone system solutions to legacy-system integration solutions.

Document Management Solutions for Pharmaceuticals

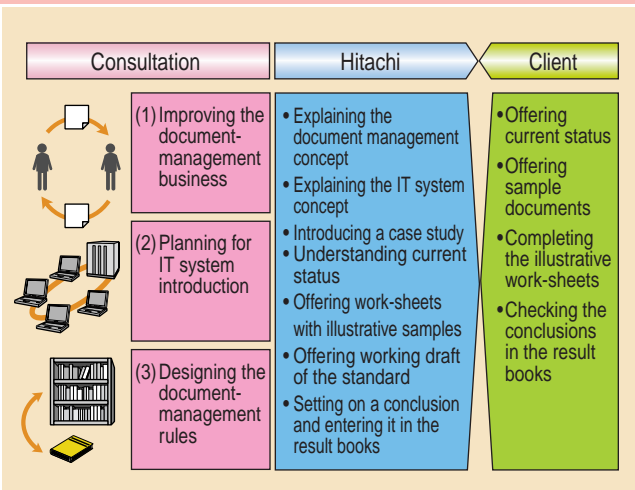

The execution of the consultative procedure

The mission of the pharmaceutical industry is to put epoch-making new drugs on the market. When putting a new drug on the market, a pharmaceutical company is obliged to provide documents on the quality, safety and efficacy of the new drug to relevant regulatory authorities as application materials. In recent years, the harmonization of the structures required for such application material and the electronic submission of applications has been promoted by ICH (International Conference on Harmonization). This is in order to promote the more rapid international circulation of new drugs. As the ICH makes progress, there is a pressing need for the pharmaceutical industry to establish an infrastructure by which it is possible to further improve the quality and reliability of application materials, and to systematically share and utilize them.

To successfully manage documents for new drug applications, Information Technology is necessary, but a suitable business process is also essential. Moreover, it is necessary to create standard in-house rules to systematically control a huge amount of documents. It is however difficult to suite the requirements of all involved in the project at the company level due to the vast scope of the documents.

The choices in terms of consultation that Hitachi offers give solutions to these problems in terms of specific project.

Figure shows the execution of the consultative procedure. (1) In the first phase of improving document management business, so as to achieve a mediation of the conflicting requirements between those involved in the project and a suitable business process, we offer some case studies of how business process have been improved and offer examples. (2) In the phase of planning for IT system introduction, so as to understand the vision of the future and the solutions that will be available in the near future, we introduce some case studies, and offer some education on standard functions of our document management system. (3) In the phase of designing the document-management system's rules, so as to establish standard in-house rules, we introduce some document-management system evolution method or checkpoint list and offer work-sheets with the illustrative examples.

As the result of the processes outlined above, confusion regarding new business procedure after the document management system has been introduced is reduced, the quality and the reliability of the documents are enhanced systematically and put to practical use, and electronic submissions to regulatory authorities are made possible.

e-Government Solution

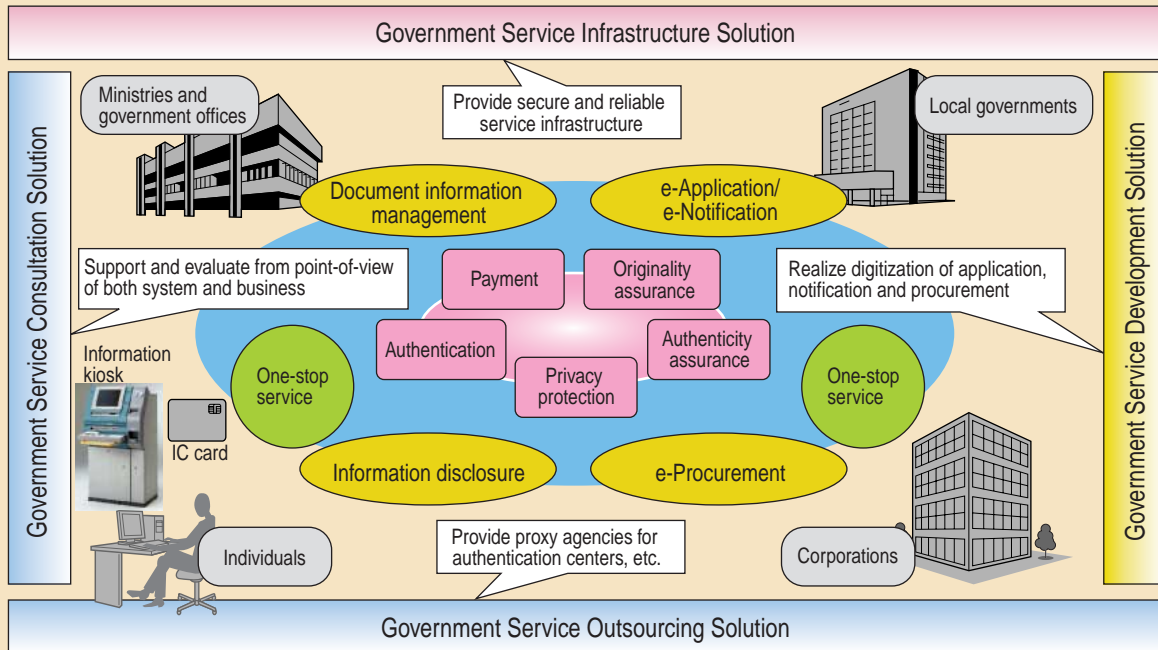

Overview of e-Government Solution

e-Government Solution strongly supports digitization of government administration by using "network technology" and "security technology" in order to meet the needs of both the people providing services and those receiving them.

As the Internet spread throughout society and the idea of 'information society' became more spread in both public and private sectors, operations such as e-applications and e-procurement are becoming commonplace. In response to this trend, the Japanese government announced 'Millennium Project' in August 1999, in which they proposed to realize the world's best standard e-Government by 2003.

Hitachi, Ltd. thinks that the most important factors in realizing speedy government administration are "instantaneousness via the Internet" and "high reliability" such as privacy protection. Accordingly, Hitachi has developed e-Government Solution with the network technology and security technology in its core.

e-Government Solution comprises the following four solutions:

- (1) "Government Service Infrastructure Solution" provides the infrastructure technology needed for digitization of government administration, such as assurance of originality and authenticity, privacy protection, authentication, and payment administration.
- (2) "Government Service Development Solution" supports

development of various administrative services such as e-application, e-notification, e-procurement, information disclosure, and document information management.

(3) "Government Service Outsourcing Solutions" provides proxy agencies for authentication centers, etc.

(4) "Government Service Consultation Solution" supports and evaluates government administration from point-of-view of both system and business.

By using these solutions, Hitachi's professionals specialized in system development at central and local government offices or private corporations can provide a comprehensive system by combining the appropriate system components according to the client's request.

In accordance with these movements, Hitachi has opened e-Government Showroom in Shimbashi, Tokyo, in March 2000. This is Japan's first dedicated e-Government Showroom and has attracted over 5,000 visitors, mainly from central and local government offices, within one year of its opening. At the showroom, people can experience a demonstration of the e-Government system and receive valuable information on products and infrastructure technologies that make up e-Government Solution.

“Administrative Electronic Window System” for Electronic Application/Registration

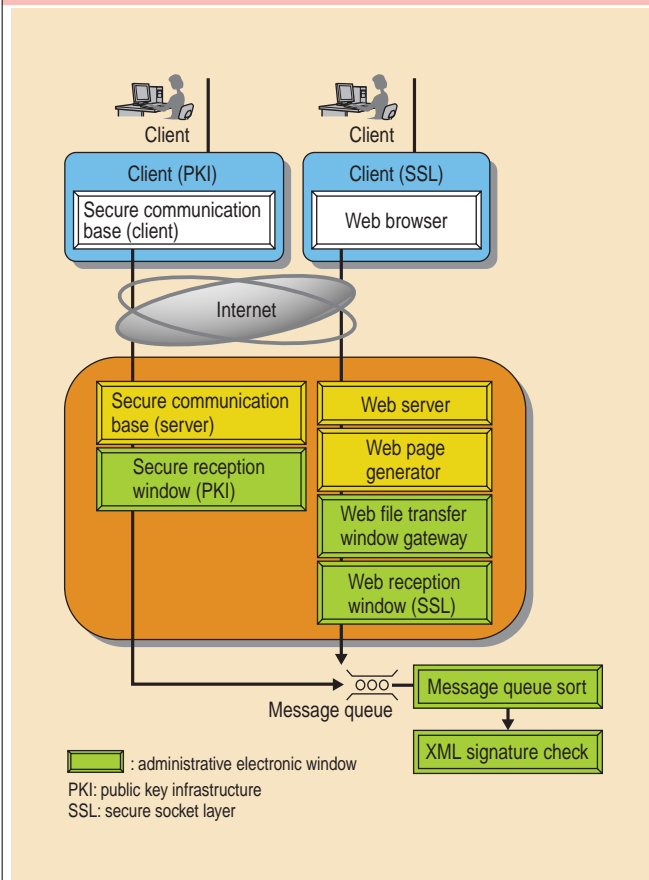

Implementation image of electronic administration window system

To establish the so-called “electronic government” (one of the goals of the Japanese government’s “Millennium Project”) by the year 2003, application and registration procedures at central government and local government offices are being computerized and a network is being established. Hitachi, Ltd. has developed the “electronic administration window system” as one solution for electronic administration.

Main features of the system:

- (1) Secure and reliable electronic application and registration procedures through the Internet.
- (2) Two-level security system and digital signature protects privacy and prevents falsification of applications/registrations.
- (3) Multi-layer architecture (including asynchronous processing) achieves stable response characteristics and simplifies system tuning to deal with load swings; excellent scalability under high-load conditions.
- (4) Industrial standard XML (Extensible Markup Language) document format supports digital signature.

The Internet-marks Solution: Authentication for Web Pages

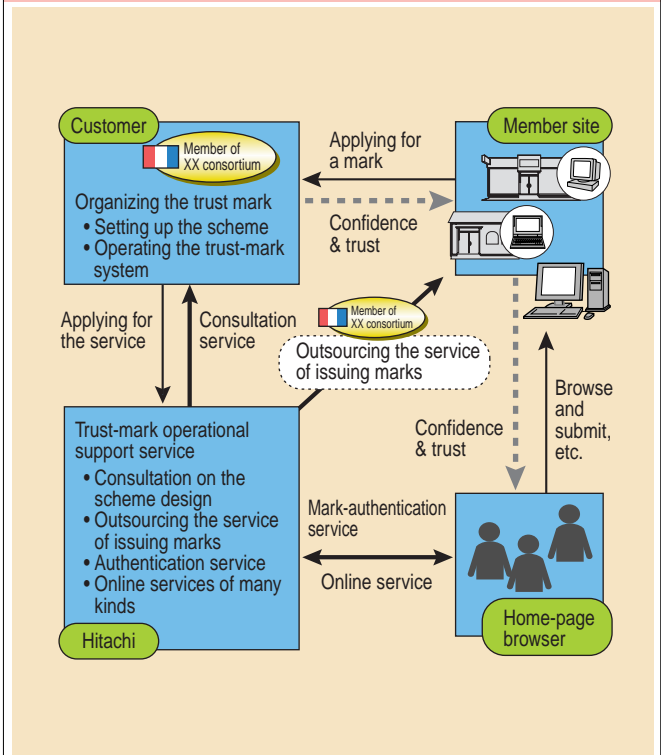

The application of an Internet-marks solution to a trust-mark system

The world-wide Web has become an important social infrastructure. For business in particular, it provides access paths for electronic commerce, so methods for the authentication of Web pages are essential. Trust-mark (or seal) programs have been put forward as a way of ensuring the authenticity of Web pages. In such programs, an authority evaluates and authorizes a Web site from a viewpoint such as that of consumer protection, and issues a mark for that authorized Web site. Hitachi has developed and launched a range of solutions for ensuring home page authenticity, which can be applied to such mark programs. The technique of marking applied by this solution consists of a digital watermarking technique and a digital signature technique, and is based on the result of research and development entrusted to Hitachi by the Telecommunications Advancement Organization of Japan. The solution enables the operation of trust-mark systems of many kinds and also allows determination of the authenticity of company logos. The system has, in fact, been adopted and used in the Japan Chamber of Commerce and Industry’s trust-mark system.

Hitachi will apply the technique to many trust-mark systems, and will also enhance the technique so that it covers ensuring the authenticity of the content of Web pages as well as the authenticity of the sites, itself. The technique will thus enable the integration and utilization of trust information on the Internet.

“Fingerprint Registration/Authentication System” for Centralized User Management and Large-scale Operation in a Distributed Environment

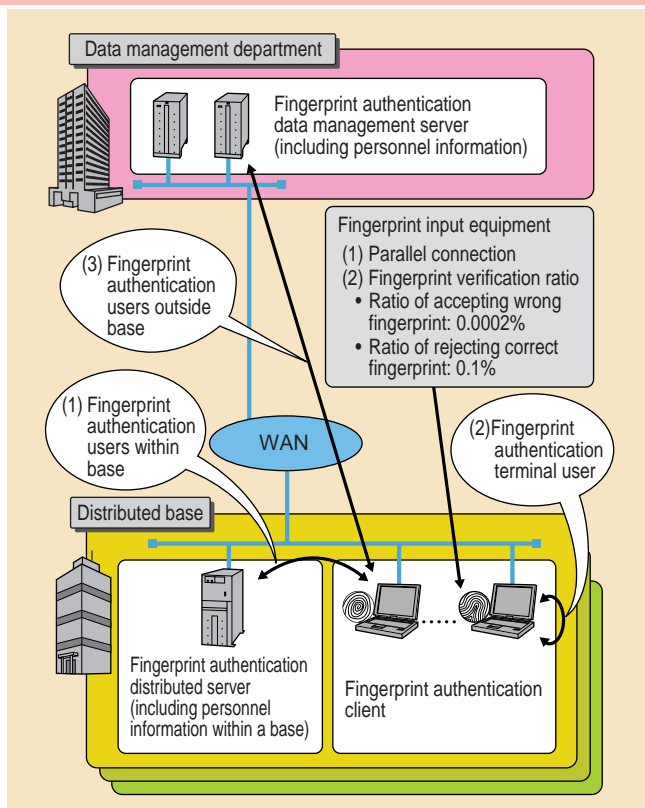

“Fingerprint Registration/Authentication System” for large-scale operation in a distributed environment

Among the various security technologies, authentication of individuals by using fingerprints has been proven to be highly reliable by its long usage history and actual performance results. Such authentication systems contain a centralized management function, which is constructed as a directory service, and are configured to accommodate large-scale operation in a distributed environment. They thus enable large-scale fingerprint authentication and registration.

Main features of the system:

- (1) Data batch management in the server enables easy management of user information (including fingerprint information). Changes in user information (due to personnel changes) are automatically sent to each distributed server.
- (2) Linking between Windows NT® log-in and fingerprint authentication.
- (3) API (application program interface) can handle fingerprint authentication requests from business applications.
- (4) A connecting server is automatically selected when a fault occurs in a distributed server.
- (5) 24 authentication levels can be set in units of individuals.

Security Software “DARManager Hacker Safe”

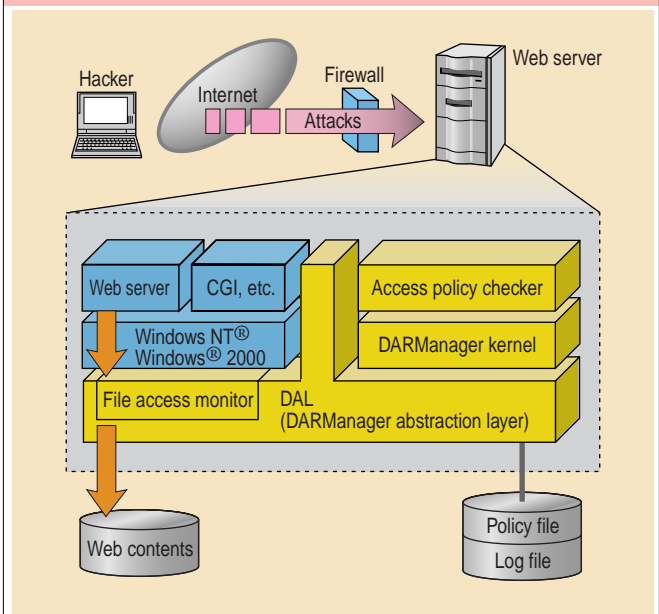

Hacker Safe is software for minimizing damage to attacked Internet server hosts. This software is developed by applying Hitachi's proprietary DARManager technology. With this technology, the operating system and DARManager kernel are able to operate independently. This makes it possible to create an environment with tight security.

The vulnerability of computer systems to security holes is a serious issue. A security hole in a program on an Internet server may allow serious damage to be inflicted on the system as a whole. Typical security products such as firewalls do not completely protect a system against attacks on its security holes. DARManager Hacker Safe has an access-control mechanism that protects information from attacks that may pass through the firewall.

Preventing the vandalization of homepages by hackers secures the social value of the pages. Blocking dishonest access to files, even by industry insiders, protects valuable data. Hindering improper leakage of business information and customer data can avoid massive losses and protects confidential relationships, so that a business enterprise's reliability can be greatly improved.

Basic functions are as follows:

- File access control: Every file access is monitored and checked against the access policy. Only specified users and specified programs are allowed access, and write access and read access by unauthorized users or programs are prevented.
- Logging of unlawful access: A log of access that violates the access policy is maintained. This log can be a key to finding the security problems (such as security holes) of an operational system.
- Setting of access policy: Access policy can be set with a user-friendly GUI tool in three different modes; file, user, or process.
- Remote control: Having a policy on access to the system consoles, which are dispersed through the network, allows tight security to be achieved. It is also possible to set an access policy and view logs of unlawful access from system consoles.
- Application to business and institutions: Regardless of the type of organization, whether enterprise, public office, bank, or school, it is possible to run Hacker Safe on any Web servers and database servers that run Windows NT® or Windows® 2000 Professional.

* Windows® and Windows NT® are registered trademarks of Microsoft Corporation.

“System Manager” Realizing Centralization and 24-hr Monitoring of Information Systems Through the Internet

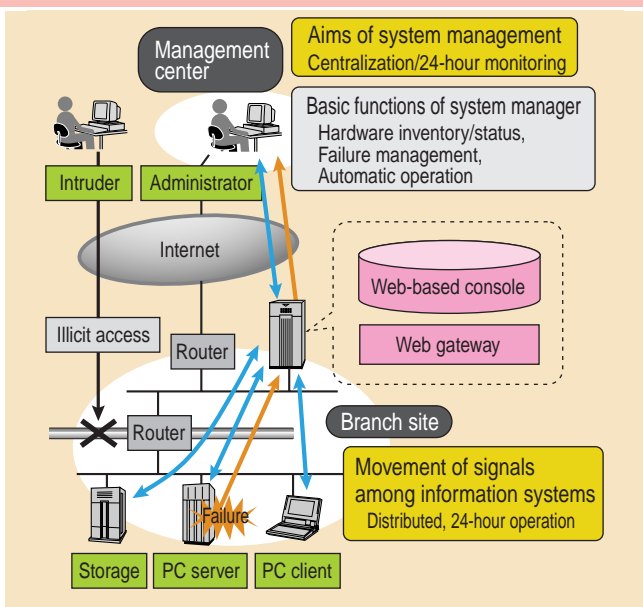

System management using the Internet

System Manager provides an infrastructure for the management of the hardware operations of PC servers, PC clients, UNIX** servers, and storage systems. It provides functions for the management of hardware inventory and state information, for the quick indication of alerts, and for automatic operation to reduce the cost of managing operations.

As information systems have a more important role in business than ever before, the requirement for information systems has radically increased. Recent movement in information systems is characterized by two key expressions, “distributed” and “24-hour operation.” Today’s enterprise information system is distributed over the world. Many branch sites have their own systems. In this case, the total cost of managing operations may be higher if each branch has its own administrator. A network-dependent business, such as an electronic-commerce business, requires 24-hour operation because the non-availability of the service caused by the system going down may be the direct cause of huge losses.

Against this background, system management tool must provide functions for the centralization of management of information distributed across the world and for monitoring failures of the system. To provide solutions to these problems, we have developed a Web-based console, which includes a Java applet, and a Web gateway. These systems allow administrators to manage information systems, 24 hours a day, and even from remote places, through the Internet.

Main characteristics:

- (1) Prevention of illicit access to the internal network by mediation of the Web gateway.
- (2) Real-time alert indication via Java***

Administrators are thus able to remotely manage hardware over information systems by using Web browser. This is possible at any time from any place, whether it be a management center, or the administrator’s home. System manager lowers the cost of system administration.

DARMA Technology for Business-purpose PCs

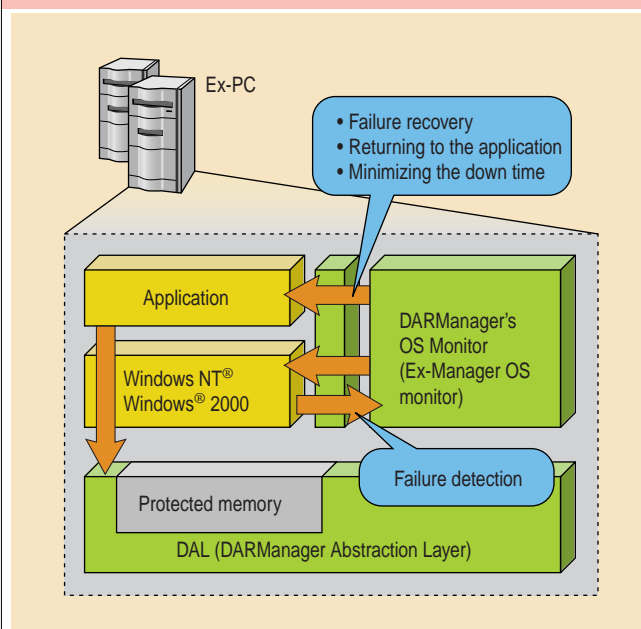

DARMA technology allows the monitoring OS to coexist with Windows NT® or Windows® 2000 in a PC. Ex-Manager makes the PC reliable, steadily available, and more manageable.

It is common to use PCs to shorten software development cycles and reduce the TCO (total cost of ownership). The deployment of PCs in business situations is, however, limited, because the PC operating systems, Microsoft®* Windows NT®* and Windows®* 2000 are neither reliable enough, available enough of the time, nor are they manageable enough.

To resolve these problems, we have developed the DARMA (dependable autonomous real-time management) technology that allows two operating systems to coexist and cooperate in a single PC. We have applied this technology and developed the highly reliable PC monitoring software package DARManager OS Monitor for our Expert-PC business-purpose PC. We have shipped PC systems with DARManager OS Monitor to many customers. For example, we have shipped such PC systems for use as the teller-terminal PCs of banks, and as reliable servers for the government.

In DARManager OS Monitor, the host OS (Windows NT® or Windows® 2000) is monitored by the special monitoring OS that is allowed, by DARMA technology, to coexist with the host OS of a PC. DARManager OS Monitor’s monitoring OS is able to tell when the host OS hangs, analyze the cause of the failure, and automatically restart the computer. This can reduce the down-times of PCs for mission-critical applications. DARManager OS Monitor also has a memory protection facility that keeps data critical to the customer’s business even in the event of unexpected crashes. Application software is able to make use of this to return to the business process after the computer has been rebooted.

* Microsoft, Windows NT, and Windows are trademarks or registered trademarks of Microsoft Corporation in the US and other countries.

** UNIX is a registered trademark in the United States and other countries, licensed exclusively through X/Open Company Limited.

*** Java and all Java-based trademarks and logos are trademarks or registered trademarks of Sun Microsystems, Inc. in the US and other countries.

Lightning9900 Series Disk Array Subsystem with the World's Largest Capacity and Highest Performance



The composition of the Lightning9900 Series disk array subsystem

With the rapid increase in Internet business, the amounts of traffic and data in corporate information systems are also increasing remarkably. Moreover, with joint-venture operations and partnerships between companies, efficient integration of information systems is a key to successful corporate strategy. Accordingly, to achieve storage enhancement, improve the value of information, and increase the efficiency of storage operations and management, the concept of storage integration on a company-wide basis is gaining momentum. To meet such needs, we have developed the Lightning9900 Series disk array subsystem with the world's largest capacity and highest performance.

(1) Large Capacity

Storage integration is a very effective means of cutting the operating costs of corporate-wide information systems. To implement storage integration effectively, increasing the capacity per disk array is crucial. With conventional systems, however, the number of disks connected was limited because the magnetic disks were controlled via the small computer system interface (SCSI).

For this reason, we have used the world's first 73-Gbyte mass magnetic disk and developed a new fiber channel control system, which enables a remarkable increase in the number of magnetic disks connected by controlling them through fiber channels. With this system, the storage capacity of each magnetic disk and the number of magnetic disks connected have been doubled. As a result, the world's highest level large-capacity disk array has been developed, with a maximum storage capacity of 27 Tbyte.

(2) High Performance

With the advent of Gbit-class fiber channels, the transaction performance is the key to the efficiency of corporate information systems. In particular, the transaction performance is crucial to success in Internet business, where quick access to and from the public is essential. In the past, improvement of the transaction performance was limited, because data was transmitted from the magnetic disks to the host side through the SCSI interface and the internal data transmission line with a bus configuration.

Therefore, we developed the world's first hierarchical star network architecture with a switch configuration and used the configuration to connect magnetic disks through fiber channels. With this system, we have improved the internal data

transmission performance to 6.4 Gbyte/s, an eightfold increase, and the transmission speed with magnetic disks to 100 Mbyte/s, a fivefold increase. As a result, the maximum transaction performance has been improved by 5 times or more compared to a conventional system, thus achieving the world's highest performance disk array.

(3) High Reliability

For corporate information systems, 24-hour, 365-day operation is crucial. In the case of Internet business, this operation is becoming more important because system failure can directly cause all business to stop. Similarly, performance degradation at the time of failure and during replacement of failed parts is also becoming manifest. For example, a duplicate bus configuration reduces performance by 50% if either side fails.

Therefore, in addition to duplicating conventional major components and the using a configuration allowing extension and replacement during operation, we developed a new multiplex switch configuration based on the hierarchical star network architecture. This minimizes the performance degradation of the data transmission line at the time of failure to only 6%. Consequently, the disk array can minimize the performance degradation at the time of failure while maintaining 24-hour, 365-day operation.

(4) Intelligent Functions and High Connectivity

The intelligent functions and high connectivity of the disk array improve the operating efficiency of corporate information systems configured in the SAN environment. This effect is particularly impressive in an environment consisting of devices from multiple vendors, a so-called heterogeneous environment.

For this reason, the data protection function, data sharing function, and storage management basic function are installed in the disk array, while at the same time, connections with mainframes, major UNIX servers, PC servers, switches, and hubs are guaranteed. This makes it easy to perform data backup, failure recovery, and other storage operations and management in a multi-vendor environment, thus enabling operation in a heterogeneous SAN environment including mainframes.

As mentioned above, the Lightning9900 Series provides the world's highest level disk array, which largely surpasses other systems in its class in terms of performance, capacity, reliability, and operability.

Thunder9200™ as SAN Generation Products

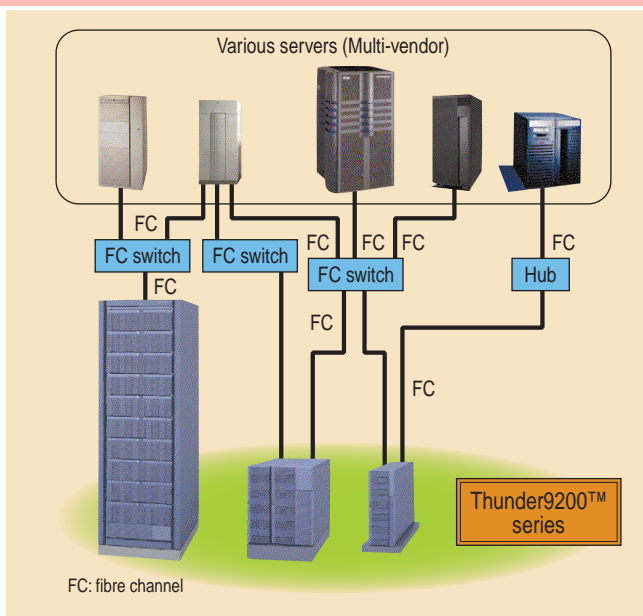

The Thunder9200™ provides customers with flexible connectivity to various servers via FC switches, hubs, and direct connection

Hitachi has developed the Thunder9200™ high-performance disk array storage subsystem as storage for SANs (storage area networks).

These new products provide the basic features of the previous product, while achieving higher performance, larger capacity, and high reliability. The Thunder9200™ can also be widely connected to low-end PC servers through high-end cluster servers in the SAN environment.

(1) High Performance

The front-end interface can be optionally selected from between a fibre channel or a SCSI interface. Transfer rates of up to 100 Mbyte/s (fiber) or 80 Mbyte/s (SCSI) per port are available. In addition, changing the back-end interface to a fiber channel and improving the performance of the controller itself enabled more than triple the performance compared with the previous product.

(2) Scalable Capacity

Up to 100 HDDs (18-/36-/72-Gbyte HDDs are available) can be mounted in a single subsystem, and the total subsystem capacity is 6.6 Tbyte. The subsystem is configured with a basic unit, which can contain dual controllers, power supplies, and up to 10 HDDs, and up to 9 extended units, which can contain power supplies and up to 10 HDDs. With these units, customers can easily expand the subsystem capacity according to their increasing demands for storage capacity.

(3) Easier Management

The Thunder9200™ includes several management programs. The disk array management program, which is used to set up the Thunder9200™, monitor failures, and so forth, includes GUI and CLI versions and runs on several platforms to improve operability and maintainability. In addition to this program, the failure notification program, SNMP (simple network management protocol), etc. can be used to manage failures of the Thunder9200™.

(4) SAN Connectivity

The Thunder9200™ provides customers with flexible connectivity to various servers via SAN, by supporting various connection devices such as switches and hubs. In addition to the above, SAN functions built into the subsystem and high availability software supported by the Thunder9200™ enable redundant and flexible system configuration.

Stand-type Image Scanner “Blinksan BS20”



Stand-type image scanner “Blinksan BS20”

Progress in information network technology has made it easy to use various kinds of image contents via networks and on PCs. Under these information environments, the stand-type image scanner, Blinksan, is so useful that it can convert various objects to electronic data, such as business documents, color copies, by using non-contact reading.

Moreover, it can scan a color page of A4 size in only about 3 seconds. It is thus suitable for a wide range of business applications, such as web content production, printing, and publishing, where jobs must be finished within a short period, and for presentation use as a document camera with a PC and projector.

Main features are as follows:

- (1) In only 3 seconds: Scan time is about 3 seconds for A4 size color forms — the fastest of this type. Operation is very simple and easy — just place the form on the reading board.
- (2) 12 million pixels, high-resolution image: With the most advanced sub-pixel image processing technology, approximately 12 million pixels of image data can be captured. The high-resolution image capability allows various uses for OCR, color document reading, and document camera applications.
- (3) Accommodate a wide range of documents:

Blinksan does not contact the paper, so a wide range of document sizes, thicknesses and qualities can be accommodated. Paper jams are eliminated.

Basic specifications are shown in the table below.

Item	Specification
Maximum document size	297 x 216 mm
Resolution	200/240/300/400 dpi
Image data stream	Black and white/grayscale/color (24 bit)
Lighting	500 to 2,300 lx (natural light)
Scanning speed (A4, 200 dpi)	Black and white approx. 2 s, Color approx. 3 s
Device interface	PCI
Device driver	TWAIN32
Dimensions	340 mm (W) x 330 mm (D) x 550 mm (H)

A Multi-function Terminal (CommunityStation III) for On-line Services in Central/Local Government



CommunityStation III

A multi-function on-line service terminal called "CommunityStation III"—which issues official documents in the conventional way and has the additional features listed below—has been developed.

Main features are as follows.

Hardware

- (1) Compact (82% of the conventional terminal's size).
- (2) Universal design, 15-inch (approx. 38 cm) TFT display that supports Braille and sign-language.

Software

- (1) Provides various kinds of information on local government agency services.
- (2) Handles resident-register network, electronic administration, and access by magnetic and IC cards. In line with the current trends in the law, electronic application for certificate of residence—from any government office—will be available as a one-stop service.

Hitachi Worldwide Cash Module — Bulk cash recycling module with versatility and flexibility —



Hitachi worldwide cash module answers the needs of customers worldwide

This is a cash recycling module handling worldwide various banknotes. By using the function, cash recycling, deposited banknotes are immediately available for withdrawal transaction. It also enables efficient use of banknotes inside ATM and reduces ATM running costs.

Hitachi's advanced cash handling technology facilitates versatile and flexible designs, readily answering the needs of a range of applications, such as dispensing, depositing, and recycling in the ATM.

Versatile and flexible

This module can handle various sizes of banknotes of countries worldwide. A wide range of operational needs, such as cash recycling, non-recycling, or deposit-only functions, are addressed by selecting different types of loading cassettes. The number of cassettes can also be selected to allow for differences in the denominations handled. Furthermore, the cassettes can be accessed from either the front or rear side of the module, enabling installation under various conditions.

High speed and easy operation

With bulk deposit/withdrawal of up to 100 notes through a single cash slot, customers receive the benefits of high speed and easy operation. In addition, the straightforward layout of cassettes adjacent to each other provides bank staff with easy access to banknote storage.

Compact size and large capacity

A two-way paper path and smart stacking mechanism enable a reduction in the module size and provide a large capacity for banknote cassettes, with each cassette holding up to 2,000 – 3,000 notes.

Hitachi leads the worldwide market with these new concepts and advanced experience and technology in the field of banking automation.

Enhancement of Gigabit Router GR2000 Series



(GR2000-2S)



(GR2000-4S)



(GR2000-6H)



(GR2000-10H)



(GR2000-20H)

GR2000 series enhanced models

IP (Internet Protocol) networks have become a very important part of the communication infrastructure. Today, various types of new IP-based applications, such as animated image, voice, and mission-critical e-trading data, are all sent together over the same IP networks.

To meet the requirements of the advanced IP networks, Hitachi began shipping the gigabit router "GR2000" series, with high performance and high quality, in 1999. Since July, 2000 Hitachi has added five enhanced models with higher performance of up to 40 million packets per second (GR2000-20H). These enhanced models also have some new features, such as IPv6, MPLS, and so on.

(1) IPv6 (IP version 6): The explosive growth of the Internet is

causing a scarcity of IP (IPv4) addresses. This function resolves the scarcity problem. Many customers are now using GR2000 as an IPv6 router in their experimental networks.

(2) MPLS (multi protocol label switching): This function is mainly for common carriers to realize traffic control and VPNs (virtual private networks). GR2000 has hardware-based label insertion function of MPLS. GR2000 is thus suitable for high-speed MPLS-VPN service.

(3) Policy-based QoS (quality of service): GR2000 has QoS-control mechanism, such as Diff-Serv (differentiated services) based in hardware. Today, GR2000 can be in combination with a QoS policy server to support automatic dynamic QoS management network.

Outstanding 1,040-km × 1.28-Tbit/s ULH-DWDM System

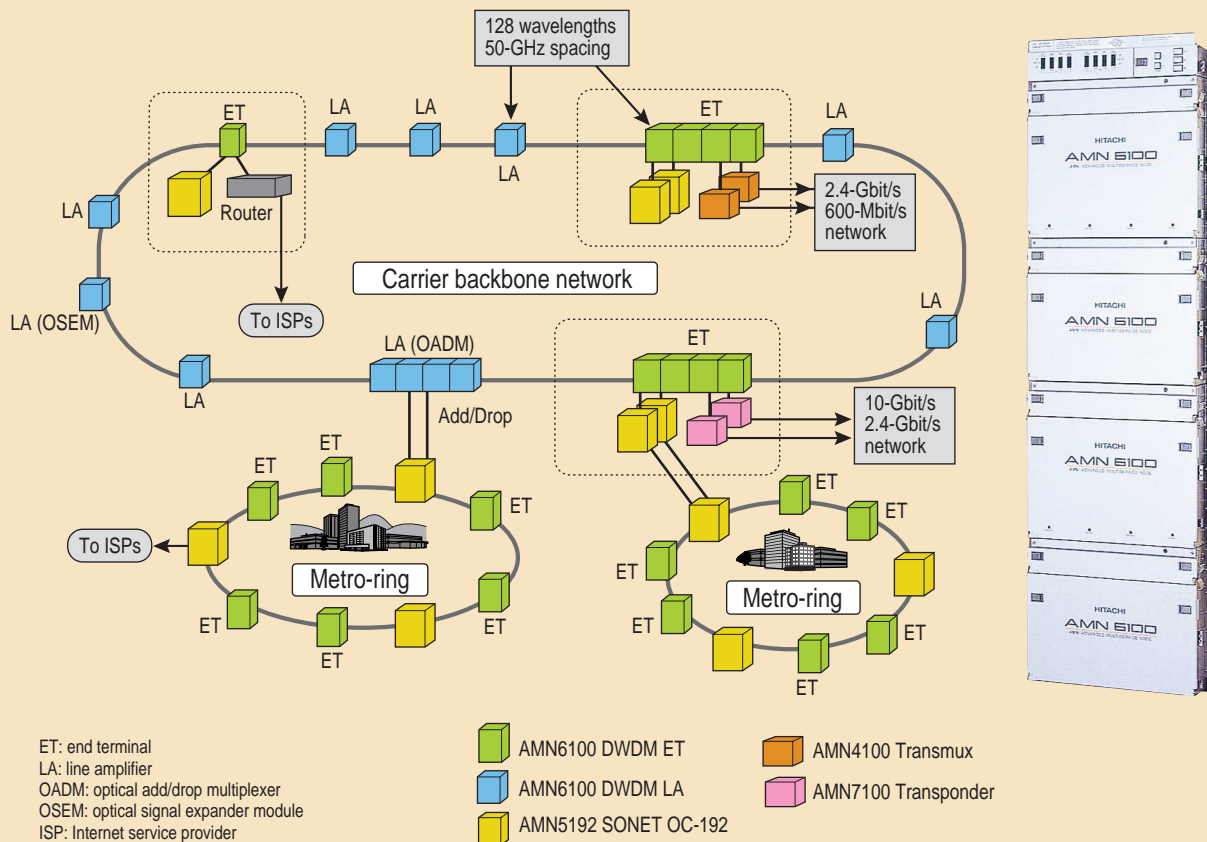

Example of optical network configuration (left) using Hitachi AMN series and front view (right) of AMN6100 end terminal with capacity of 1.28 Tbit/s

To cope with the rapid growth in Internet and electronic commerce demand, the dense wavelength division multiplexing (DWDM) system has been one of the hottest topics in the telecommunication market. By virtue of this system's capability to transmit many signals via a single fiber, the capacity of backbone networks has been increasing enormously. The topic is now shifting to the transmission distance, especially in vast areas, such as North America, Europe, and so on. Because large cities are highly dispersed, the technology to optically transmit signals over long distances is desirable.

Hitachi's DWDM system AMN6100 has been designed to respond to these market demands. It achieves ultra-long haul (ULH) transmission over a distance of up to 1,040 km, which doubles the transmission distance of a conventional system. With this ULH technology, AMN6100 can provide an exceedingly cost-effective solution by reducing the regenerator and installation area. Simultaneously, AMN6100 enables an enormous terabit-order transmission capacity, handling 10 Gbit/s × 128 channels, totaling to 1.28 Tbit/s in a single fiber. AMN6100 helps carriers and ISPs (Internet service providers) to use their resources more efficiently.

The following are the major features of AMN6100:

- (1) AMN6100 provides 1,040-km ULH transmission without regeneration. The technologies of gain tilt compensation (GTC) and low noise figure (LNF) amplifier provide the core of ULH.
- (2) AMN6100 consists of a 16-channel unit expansion system improving the performance for channel expansion to its highest level. By adopting 50-GHz spacing obeying an ITU-T grid, up to 128 channels, providing 1.28 Tbit/s can be installed in one bay.
- (3) Hitachi's automatic gain tilt control (AGC) substantially suppresses effects due to various external factors, thereby suppressing deviation among wavelengths at the optical output stage to within ± 1 dB.
- (4) An optical Add/Drop multiplexer (OADM) device enables 4 channels to be added or dropped for each 16 channels at a line amplifier site.
- (5) Optimizing the control circuit of each package decreases power consumption, thus minimizing customers' operating costs.

In addition, the AMN6100 system will be improved to provide further transmission capabilities. With the new upcoming technology, the optical signal expander module (OSEM) extends the transmission distance up to 8,000 km. AMN6100 system keeps improving as the world's networks develop.

10-Gbit/s Transparent Multiplexer System

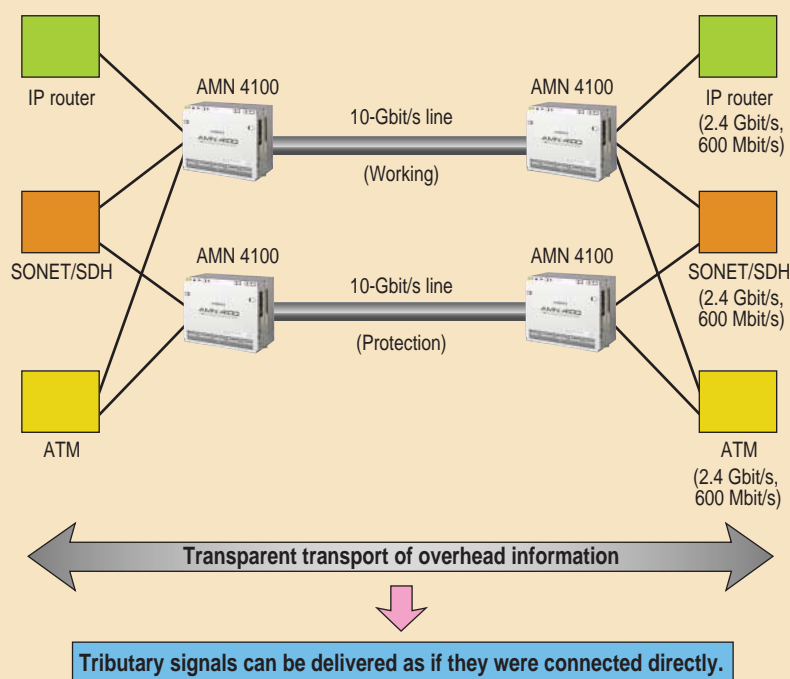

10-Gbit/s transparent multiplexer system

IP: Internet protocol
SONET: synchronous optical network
SDH: synchronous digital hierarchy
ATM: asynchronous transfer mode

Example of optical network using 10-Gbit/s transparent multiplexer system (ANM4100)

The AMN 4100 transparent multiplexer system is a SONET (synchronous optical network) OC-192 TDM multiplexer, which multiplexes and transmits lower level OC-12 and OC-48 signals to the OC-192 line rate in a backbone network and provides a powerful yet economic solution for network capacity growth.

The AMN 4100 offers a transparent transport function, which transfers low-speed-signal overhead information about operation and management, such as APS (automatic protection switching), DCC (data communication channel), and Orderwire, without modifying the information as it passes through the 10-Gbit/s backbone network. The transparent transport function is achieved by transmitting overhead information within the unused part of the OC-192 overhead bytes. Thus, Hitachi's AMN 4100 can support multi-vendor UPSR (unidirectional path switched ring), 2F-BLSR (bi-directional line switched ring), 4F-BLSR, and linear protection OC-12/48 SONET equipment.

The combination of the multiplex and transparent transport functions enables service providers to maximize their utilization of valuable fiber infrastructure and protects existing investments in SONET, while providing lower cost, high-bandwidth transport. In addition, the modular design of the AMN 4100 provides the flexibility required for timely response to increases in traffic capacity demand.

Hitachi's AMN 4100 system has been deployed to the "North American Crossing" network of Global Crossing Ltd., which covers more than 100 major cities in the US. Also the system has been deployed in the company's US-and-Europe undersea cabling system, which connects New York and London. In addition, the system will be deployed to the US network of Norlight

Telecommunications, Inc. named "Future-Proofs."

The major features of the AMN 4100 are as follows:

- (1) The AMN 4100 achieves maximum capacity on 10 Gbit/s per fiber. It provides transport at the OC-192 line rate and has traffic drop-and-insert capability at the OC-48 or OC-12 SONET signal rates.
- (2) The AMN 4100 maximizes the channel capacity of DWDM systems. It can operate as a tributary multiplexer with DWDM equipment. OC-192 optical interfaces are compatible with the Hitachi AMN6100 DWDM system.
- (3) The transparent transport function maintains SONET protection and survivability in ring, 1+1, and 1:N configurations. APS protection protocols pass through the AMN 4100 to maintain 50-ms switching.
- (4) Forward error correction (FEC) can be turned on or off without impairing traffic. This feature allows errors on OC-192 lines to be corrected by using Reed-Solomon code to improve the effective bit error rate.
- (5) A single shelf supports up to 10 Gbit/s (up to 16 OC-12 or 4 OC-48 tributaries, or a combination of OC-12/OC-48 up to 10 Gbit/s), with up to 4 shelves in a single bay.
- (6) The AMN 4100 provides facility and terminal loop-back on tributary interfaces.
- (7) The AMN 4100 features a user-friendly element management system that can manage DWDM transponder systems or stand-alone multiplexing systems. The AMN 4100 also supports the existing North American TL1 interface over TCP/IP data communications channel (DCC) and LAN/WAN stacks. DCC messages are carried by using a standard TL1 over TCP/IP.

Next-generation Mobile Communication System Using HDR Technology

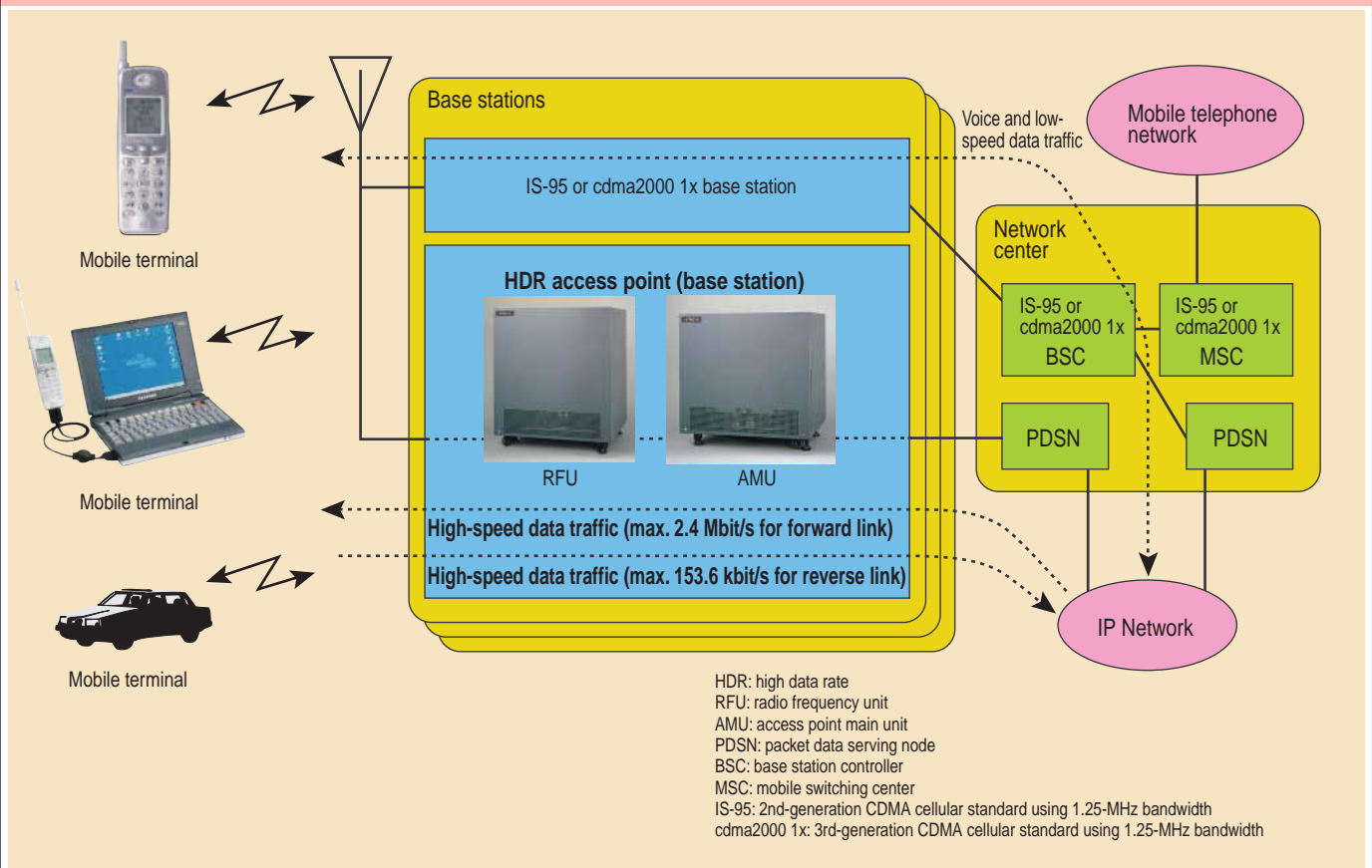

HDR system configuration

Hitachi has developed and delivered a trial system for high-speed wireless packet communication using HDR (high data rate) technology to IDO Corporation (currently, KDDI Corporation).

High-speed mobile Internet access is one of the key applications of HDR systems. Optimized for IP (Internet Protocol) traffic, HDR's air interface allows flexible implementation of this system in a high-performance, cost-effective way.

The trial system has been installed in the Tokyo metropolitan area, and it has demonstrated high-speed mobile Internet communication in a real application.

Major features of the HDR commercial system are as follows:

- (1) By using a variable-rate modulation and demodulation method between mobile terminals and base stations, maximums of 2.4 Mbit/s for forward-link and 153.6 kbit/s for reverse-link high-speed communications are possible.
- (2) Connecting the HDR access point directory to IP backbone equipment, HDR allows cost-effective implementation for data networks.

The system was delivered in June 2000.

MSA-based 10-Gbit/s Optical Transceiver Modules with Integrated MUX and DEMUX

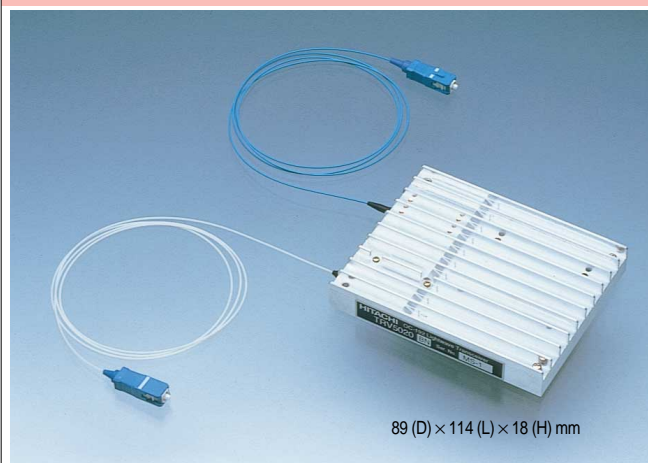

MSA-conforming 10-Gbit/s optical transceiver module with integrated MUX and DEMUX

OpNext, Inc. (formerly Hitachi Fiber Optic Components Business Unit) has developed 10-Gbit/s fiber-optic transceiver modules with a 16:1 multiplexing (MUX) and 1:16 demultiplexing (DEMUX) circuit. These modules can be used in high-speed optical network systems, Internet protocol (IP) switches, and IP routers.

The maximum transmission distances of the transceiver modules are 12 km and 40 km for the 1.3- μ m and 1.5- μ m optical wavelength versions, respectively. The optical and electrical interface of the modules conforms to the 10-Gbit/s transceiver multi-source agreement (MSA) originally proposed by OpNext, Inc., Agere Systems, and Alcatel Optronics. Consequently, these modules are compatible with transceiver modules made by other MSA member companies.

By using high-speed, low-power silicon-germanium ICs, the transceiver modules are integrated into a compact size (89 mm \times 114 mm \times 18 mm), and achieve low power consumption (9.5 W). The modules consist of an optical transmitter and receiver, a 16:1 multiplexing circuit with clock synthesis, a 1:16 demultiplexing circuit with clock and data recovery, and a transmitter-reference-clock jitter filter that provides good jitter performance.

MSA-based 2.5-Gbit/s Optical Transmission Modules

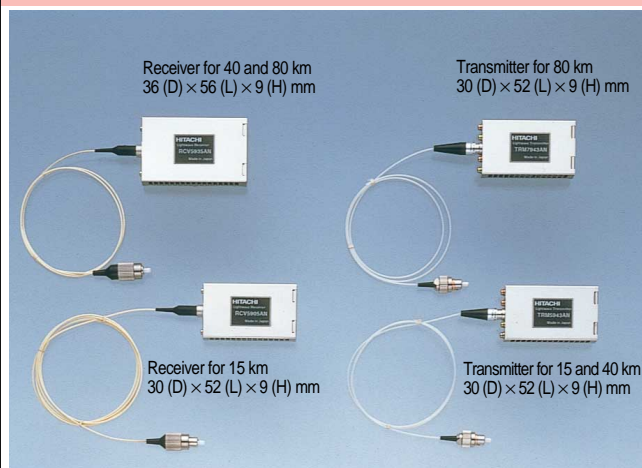

MSA-based 2.5-Gbit/s optical transmission modules

OpNext, Inc. (formerly Hitachi Fiber Optic Components Business Unit) has developed 2.5-Gbit/s optical transmission modules based on the multi-source agreement (MSA) between a group of six companies consisting of Agere Systems, Alcatel Optronics, Ericsson, Mitsubishi Electric Corp., Sumitomo Electric Industries, Ltd., and Hitachi, Ltd.

The main features are as follows:

- (1) Very large-scale integrated circuit enabled by high frequency Si-IC technology
- (2) Development of FCA (flip-chip attachment) mounting technology
- (3) Adoption of a WTR-LD (wide-temperature range laser diode)
- (4) Implementation of a high-precision optical input level monitor function
- (5) Coverage of 15-, 40- and 80-km transmission distances
- (6) Suitability for dense wavelength division multiplexing (DWDM) transmission equipment, etc.

cdmaOne Cellular Phone



cdmaOne cellular phones. C309H in silver body (left) and orange body (right)

Hitachi has been developing advanced features for KDDI's cdmaOne* service, such as EZweb (IP connection service), polyphonic ringer, packet data transfer, and color picture contents.

Hitachi is devoted to developing leading technologies for cdmaOne cellular phones. In 2001 and beyond, such leading technologies include GPS (global positioning system) and Java**. GPS is expected to lead to new services, such as location-base services for users. Java is expected to be used to distribute contents, such as games and information. Java has been developed as a common language for computing by Sun Microsystems.

In addition, cellular phones will be a new medium for video and

music distribution. Hitachi believes the cellular phone market will reach an era of innovation in 2001 or 2002 with the emergence of high-speed data transfer technology and new services based on this technology.

Hitachi has been and will be devoted to developing new cellular phones with leading technological advances and new services.

* cdmaOne is a registered trademark of the CDMA Development Group.

** Java and all Java-based trademarks and logos are trademarks or registered trademarks of Sun Microsystems, Inc. in the US and other countries.

Micro-portable LCD Projector



Micro-portable LCD projector, "CP-S220"

Hitachi launched a micro-portable LCD projector, "CP-S220." Because of its B5 size and 2.4-kg weight, it is convenient to carry and easy to set up in a small room. In developing this new projector, we targeted four features appropriate for use in small rooms: short-distance projection, quietness, light weight, and low price.

Major features are as follows:

(1) A large screen display became possible even for a small room

by using a newly developed lens with the world's shortest focus length. The CP-S220 has the capability to project a large, 60-inch screen image from a distance of 1.5 m (5 ft) and a 100-inch screen image from 2.4 m (8 ft).

(2) A low noise level of 34 dB was achieved. Such low-noise operation is especially important for use in a small room.

(3) The CP-S220 generates 800 ANSI lumens in a small body as compact as B5 size, 60 mm in height, and as light as 2.4 kg.

Digital High-definition VCR DT-DR20000

Hitachi has introduced the digital high-definition (HD) VCR, DT-DR20000 which records and plays digital HD broadcasting programs, which began in December, 2000. In the DT-DR20000 a DBS (digital broadcasting satellite) HD tuner or HD TV is connected with a built-in DBS tuner by an IEEE1394 connection.

Main features are as follows:

(1) By incorporating an MPEG2 encoder, this VCR can record analog broadcasting programs, such as terrestrial or BS (analog broadcasting satellite) signals, in a high-quality digital format.

(2) It has four digital recording modes, so that users can select the mode depending on the program. A 420-minute tape will record 3.5 hours of DBS HD programs with the highest quality (HS), or 7 hours with standard quality (STD), or even 14 hours (LS2) or 21 hours (LS3) in long recording mode.

(3) It is also compatible with S-VHS and VHS systems.



Digital high-definition VCR "DT-DR20000"

37- and 42-inch High-definition Plasma Displays



37-inch (left) and 42-inch (right) high-definition plasma displays

The Hi-Plasma® CMP307X is the first plasma display model on the market that is compatible with the 1,024 × 768 pixel high-definition XGA format with a 4:3 aspect ratio. Depending on the image displayed, the CMP307X can be set for reproduction in either 2.09 million-color mode to optimize sharpness and brightness, or 16.77 million-color mode to optimize picture quality. This model also has a new feature to reduce image retention for still pictures.

The Hi-Plasma CMP4120HD is a fully HDTV-compatible 16:9 aspect-ratio plasma display that combines stunningly high 1,024 × 1,024-pixel resolution with significantly brighter images and much

higher on-screen contrast than any previous plasma model (panel brightness: 600 cd/m² at white peak; contrast ratio: 700:1, no ambient light). This model also has the feature to reduce image reduction.

Future trends of plasma displays are higher brightness, higher picture quality, lower power consumption, and better cost performance. In the near future, the brightness is expected to be double the current level due to improvements in the driver method and phosphors, and increased aperture.

* Hi-Plasma is a registered trademark of Hitachi, Ltd.

High-resolution Liquid-crystal Rear Projector Series



Stand-alone type (above) and multi-display unit (below)
(Screen images shown here are artificially overlaid.)

Hitachi has developed a new lineup of Liquid-Crystal Rear Projectors, which feature high brightness, resolution, and reliability, save space, are easy to install with their cube structure, and are compatible with various kinds of input signals.

The new lineup consists of a multi-display type with a 70- or 50-inch screen and a stand-alone type with a 70-inch screen. In addition, stand-alone types with larger screen sizes, such as 80 inch, 100 inch, and 110 inch will be added to the lineup. A 74-inch type compatible with HDTV and a 60-inch multi-display type will further reinforce the lineup.

Hitachi's display systems have been used in a wide variety of applications as security and control systems, such as disaster prevention and traffic monitoring systems, and also as presentation systems. The high-quality presentation capability and high reliability meet the requirements for monitoring and control systems resolution.

Hitachi has also developed an MGT (multi-graphic terminal) system for the multi-display type. The MGT enables multiple operators to place their own information and data on the screen without being limited to the base screen size. The easily operated of the MGT requires fewer operators.

With this new lineup of projectors, Hitachi aims to be the best solutions partner while satisfying the various demands of various applications in Japan.