



# Industrial Systems

Industrial Systems  
Environment  
Steel and Chemical Plants  
Public Facilities  
Automotive Systems  
Transportation  
Building Systems  
Healthcare Systems  
Semiconductor Manufacturing  
and Inspection Equipment  
Materials

## Development of 22-kV/400-V Pad-mounted Transformer

A new type of 22-kV/400-V PMT (pad-mounted transformer) has been developed to support promoting 22-kV/400-V distribution systems. The apparatus is compact [same as 6-kV PMT:1,100 mm (W) × 450 mm (D) × 1,450 mm (H)] and has a large capacity.

The 22-kV switch, the first part of the PMT, uses reliable vacuum insulation, which is environmentally clean. It has three LBSs (load break switches) and two ESs (earthing switches) are contained in its phase-divided vacuum housing. The transformer, the other part of the PMT, uses silicon oil for insulation because of its high breakdown voltage and its robustness to high temperature. It also uses a 24-kV current-limiting in-oil fuse, which is installed in the same tank as the transformer. Moreover, the effectiveness of heat dissipation from the upper part is increased by arranging the conservator in the lower part of the transformer. These features contribute to its compactness and its large capacity.

To ensure safety if ground faults occur, the 22-kV switch has a completely separated phase-by-phase structure and the inner and outer boxes are double insulated.

[Main specifications]

Rated primary voltage: 22 kV

Rated secondary voltage: 400/230 V

Power-frequency withstand voltage: 38 kV

Thunder Impulse withstand voltage: 75 kV

Transformer capacity: 300 kVA

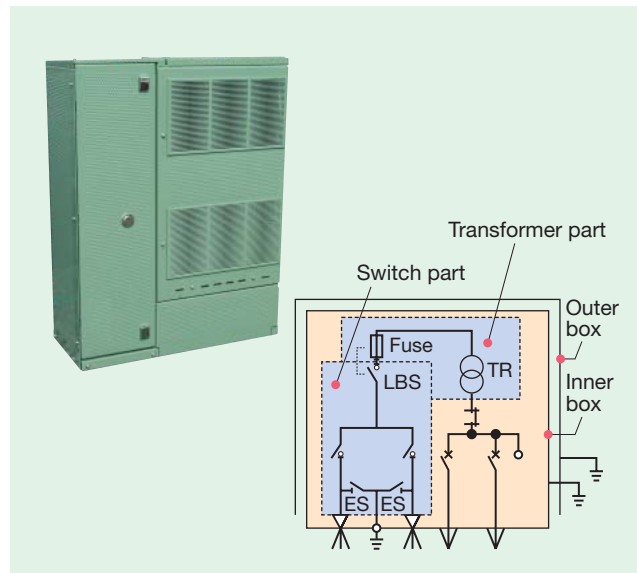

Appearance of 22-kV/400-V pad-mounted transformer, and single line diagram

## Mini UPS with Various Functions

Stable and affordable system operations for system administrators are urgently required in the information technology field for ubiquitous computing. To meet this, Hitachi has released a new series of small capacity UPSs (uninterruptible power supplies), which have various functions and a range from 1–8 kVA.

[Main features]

(1) Various UPSs can be controlled in coordination with Job Management Partner 1, an open middle-ware for systems administration.

(2) UPSs can be controlled in coordination with a function for scheduled operation of the 9500 series disk array subsystem.

(3) It is easy to expand the system with functions that connect multiple servers with one UPS providing a cluster architecture for servers.

(4) 2% higher reliability with on-line UPS than the conventional Hitachi model

Hitachi is also going to improve the large-capacity UPS series by applying the same functions and facilities, and provide highly reliable power supply systems with this lineup of multi-function UPSs.

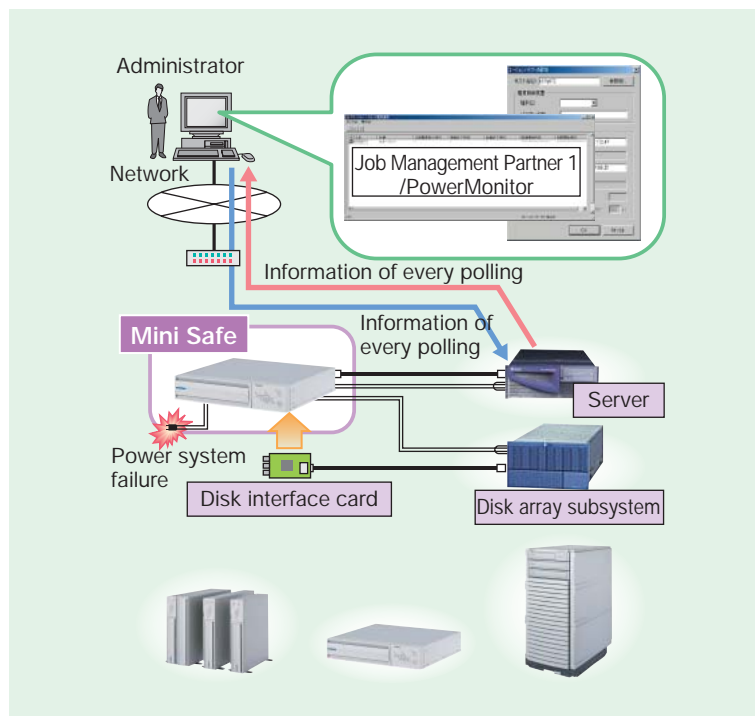

System using new mini UPS (above) and appearance of new mini UPS



## Three-phase Induction Motor with High Starting Torque and Low Starting Current



Three-phase induction motor with high starting torque and low starting current

Hitachi released a new induction motor, which has high starting torque and low starting current. The new motor is squirrel-cage type and tough in operation, and can be used for pulverizers and crushers. In general, a squirrel-cage type induction motor requires a high starting current because of its high starting torque. Auxiliary equipment (e.g. reactor or autotransformer), or a wound type motor is used when the above characteristic is needed. High starting torque is obtained at a low starting current in the new motor due to sophisticated design based on the latest electromagnetic analysis.

[Main features and specifications]

- (1) High starting torque and low starting current
  - (2) Cost saving — Additional equipment (e.g. reactor or autotransformer) is not required.
  - (3) Low maintenance work — No brushes or slip rings
  - (4) Motor specifications — Output: 55–5,000 kW, Voltage: 3–6.6 kV, Poles: 2, 4, 6 and 8 poles
- In addition to the above uses, this new motor is suited for use with pumps and fans for the purpose of reducing starting current.

## Direct-drive Variable-speed Wind Turbine System for Remote Islands

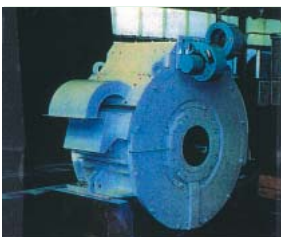

115-kW permanent magnet synchronous generator (above left) and 100-kW power conditioning system (below right)

Hitachi developed key electrical components used in a small wind turbine system for remote islands, which consists of a PMG (permanent magnet synchronous generator) and PCS (power conditioning system).

The PMG is configured with multiple poles that enable direct connection between the wind turbine rotor and PMG rotor. Mechanical equipment can be made smaller and simpler with this configuration.

The PCS controls the PMG speed to the most suitable according to wind speed through variable-speed control, where sensorless vector control is adopted to detect the rotor position of the generator, so that it can generate electric power efficiently regardless of wind speed.

Functions such as soft starting and reduced harmonics to improve power quality can also be applied to the PCS.

[Main specifications]

- (1) PMG — Rated output power: 115 kW, Rated output voltage: 360 V, Poles: 60 poles, Stator winding: concentrated
- (2) PCS — Rated output power: 100 kW, Output voltage: 300 V

## Programmable Controller: S10V

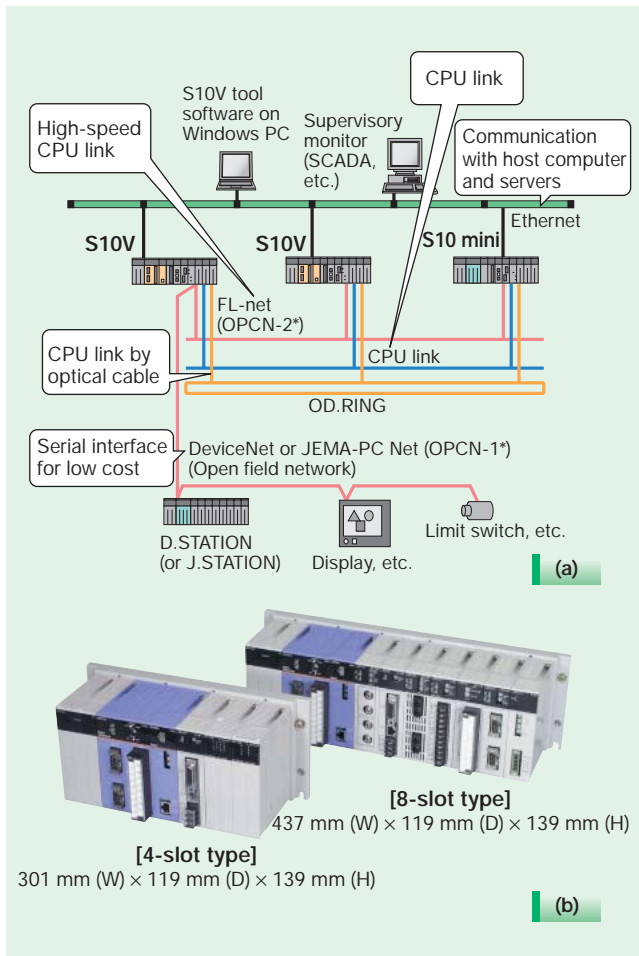

The new S10V model can be used for various controls and factory automation systems on automobiles and in tire production lines. The S10V supports not only the popular Ladder language but also a flow chart language for the controls. Because the flow chart program shows an image of the machine movement, even complicated machinery controls can easily be programmed. Since monitoring and debugging are possible on the flow chart program, software productivity improves. The user's C language programs can handle data processing easily because of the real-time multitasking OS (operation system).

### [Main features]

- (1) Flow chart language for sequence controls
  - (a) Multiple flow processing
  - (b) Easy debugging because of flow chart execution monitoring
- (2) C language for data processing
  - (a) High performance using SH-4 160-MHz processor
- (3) Ladder language for inter-lock controls
  - (a) High speed execution  
Basic instruction: 15 ns per step

\* OPCN (Open PLC network)-1: The open network of a device level where JEMA (The Japan Electrical Manufacturers' Association) is advancing standardization

\* OPCN (Open PLC network)-2: The open network of a controller level where JEMA (The Japan Electrical Manufacturers' Association) is advancing standardization

Example of network system configuration (a) and external view of S10V (b)

## New 55/75-kW Machines in HISCREW2000 Series

The global awareness of the need to save energy led to the development of 55/75-kW oil-flooded air compressors, the HISCREW2000 series.

### [Main features]

- (1) The use of power-saving parts, etc. reduces total input power approximately 3% compared with conventional machines. The use of a new dedicated profile rotor increases the discharge air capacity by 2-6% and improves the functioning of the whole unit.
- (2) The machines with their built-in inverter are made more user-friendly by PQ wide mode, which can control the air capacity and pressure independently.
- (3) The use of a new synthetic oil reduces the ratio of oil in use by 25% compared to conventional machines.



OSP-55VA1: air compressor with built-in inverter



## New Super Amorphous Molded Transformer



Super amorphous molded transformers

A transformer is generally expected to be one of the most highly effective pieces of electrical equipment. However, when the amount of conversion energy is large, the absolute value of the loss is also large. Moreover, because electrical power is always supplied through the transformer as it is the main piece of equipment in a power substation, its total electrical loss becomes very large.

The new super amorphous molded transformer is constructed with an amorphous core and winding that are totally enclosed in high-quality biodegradable resin. The molded transformers are widely used in facilities such as hospitals, railway stations, underground shopping centers, and large department stores with fire and disaster prevention regulations. The “super amorphous molded transformer” conserves as much energy as existing molded transformers.

[Main features]

- (1) Due to its amorphous core construction and optimized winding structure, total losses are reduced to about 46%.
- (2) The amount of carbon dioxide exhaust per year is reduced by about 3.9 tons (compared with our current molded transformer: 3-phase, 500 kVA, 50 Hz, 40% load).
- (3) Prevention of a second disaster by adoption of biodegradable resin instead of insulating oil

## Hitachi Air Shower Series for Clean Rooms

Hitachi released a new Hitachi air shower series for clean rooms. Air shower equipment, which is installed at the entrance of clean rooms removes dust from workers with airflow nozzles, and prevents contamination from the outer atmosphere. Research was conducted to compare dust-removal efficiency of a conventional spot-jet nozzle that directly blows against workers and the new airflow-vibration nozzle that blows all over them. The airflow-vibration nozzle uses the Coanda effect and achieves much higher dust-removal efficiency than the conventional nozzle. The results indicate that the new nozzle can decrease the time to remove dust from 15 to 8 seconds and remove 11 % more dust than the conventional nozzle.

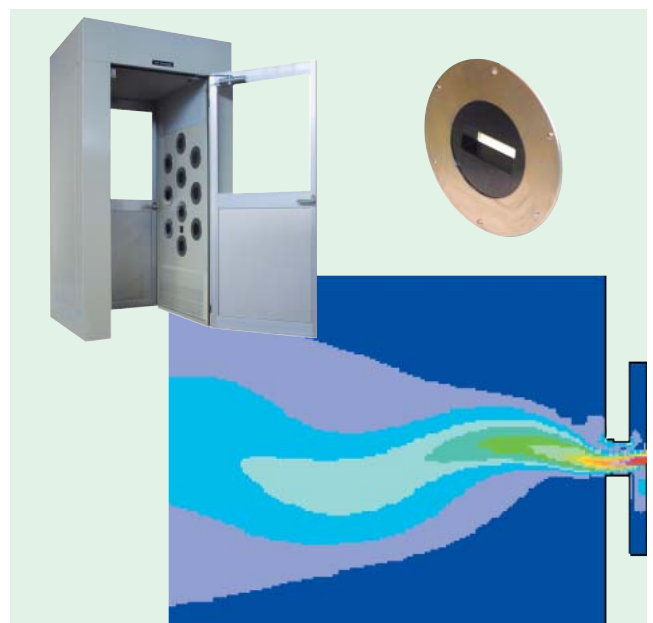

Hitachi air shower series for clean rooms

## Air-cooled Type/Air-to-water Heat Pump Type R407C Top-class-efficiency Water Chillers with Screw Compressors (40–120HP)

Besides the need that has increased in recent years in office buildings, plants, and other buildings to reduce energy costs, customers are now more strongly aware of the need to purchase products that consume less energy and are friendlier to the environment by using refrigerants with no ODP (ozone depletion potential) and also reduce the total volume of CO<sub>2</sub> emissions.

In order to respond to those needs, Hitachi worked jointly with Tokyo Electric Power Co., Inc., Chubu Electric Power Co., Inc. and Kansai Electric Power Co., Inc. to develop the ultra-efficiency AH Series of chiller units that realized the world's highest level of COP4.1/3.7 (cooling capacity of 160/180 kW: 50/60 Hz).

[Main features]

- (1) By utilizing a high efficiency screw compressor and a newly developed twin-bladed propeller fan, the highest COP was reached with an exclusive air-cooled type that does not use evaporative condenser.
- (2) Utilizes the new R407C refrigerant that has no ODP.
- (3) By reducing the amount of power consumption, contributes also to reducing CO<sub>2</sub> emissions.
- (4) Quantity of refrigerant is 15% less than in similar units Hitachi produced 15 years ago.
- (5) Through ideal positioning of refrigerant cycle parts, unit was made an average of 17% more compact. When replacing old

units to new units, installation space can be utilized more efficiently.

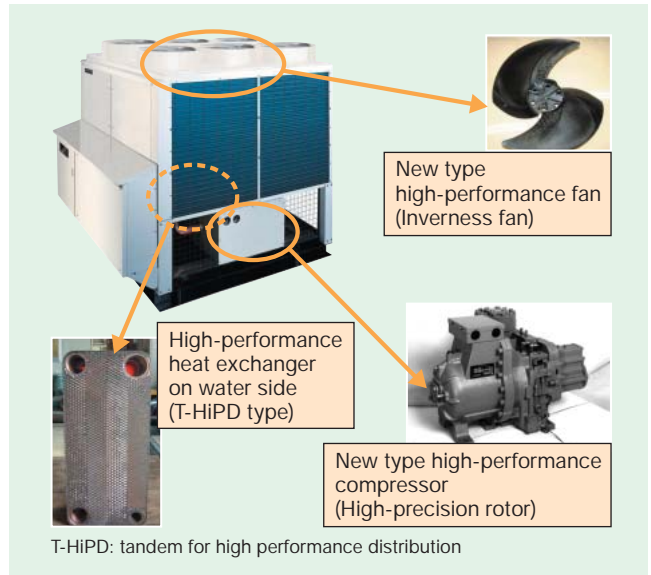

Air-cooled type, air-to-water heat pump type R407C top-class-efficiency screw chiller units (40 – 120HP)

## Highly Efficient, Compact Multi-split System Air Conditioner for Medium/Large Buildings

There is increasing competition today for conserving electric power and other forms of energy. In that backdrop, Hitachi has developed the new series of highly efficient, compact multi-split system air conditioner for medium/large buildings.

[Main features]

- (1) Efficiency has been raised 8 – 18% compared to Hitachi's conventional equipment, and required floor space for outdoor unit has been decreased a maximum of 37%.
- (2) Equipped with newly designed high-efficiency scroll compressor; scroll compressor efficiency has been increased 5% through optimized asymmetrical scrolls, sub bearings, and flow of lubricating oil.
- (3) In pursuing ultimate performance, the fan efficiency was raised 70%; a high-performance twin-bladed propeller fan is used with the fan unit emitting 5-dB less noise.
- (4) An R410a refrigerant is used that has no ODP (ozone depletion potential).
- (5) Using electric wires a new communication system was developed for transmitting control signals to equipment in several different rooms without requiring transmission lines or related installation work.

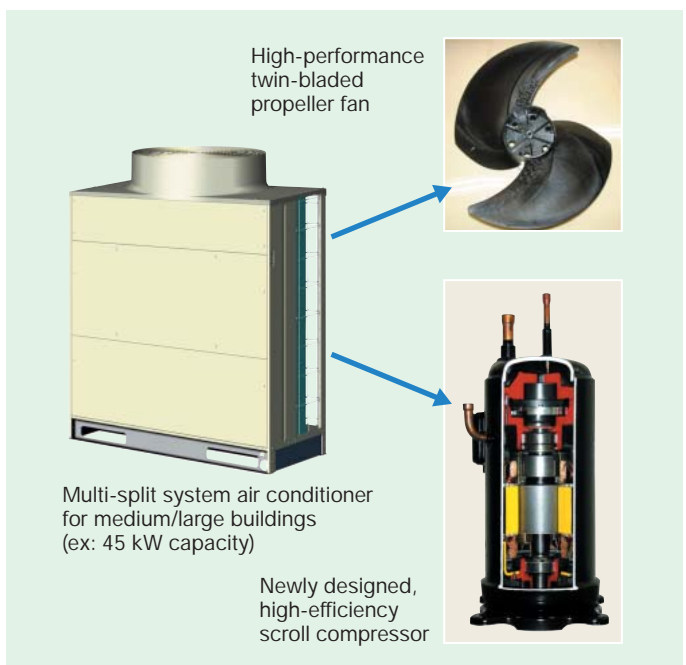

Highly efficient, compact multi-split system air conditioners



## Multi-beam Laser-drilling Machines with Increased Productivity

More printed wiring boards are being produced especially in areas where they are required to have higher interconnection density and higher bandwidth. To meet these demands, two new multi-beam laser-drilling machines, the first with a CO<sub>2</sub> laser and the other with a UV (ultra-violet) laser, enabling increased productivity have been developed.

[Main features]

(1) Two full-size (560 × 620 mm) panels for printed wiring boards can be mounted at a time on each of the two machines. As a result, the drilling productivity of each machine is increased by approx. 35% compared to that of the previous multi-beam model that processed one panel at a time.

(2) Cutting-edge digital servo-technology to reduce the short-pitch via-hole drilling time has been incorporated into the new CO<sub>2</sub>-laser drilling machine, which can directly drill via-holes as small as 50 μm in diameter in a resin-insulation layer without the need for a mask. Conformal mask drilling, large-window drilling, and copper-direct drilling are all thus possible.

(3) The new UV-laser drilling machine whose beam has an even power distribution can directly drill via-holes as small as 30 μm in diameter in a resin-insulation layer.



Multi-beam CO<sub>2</sub>-laser drilling machine: LC-2F212 (below) and multi-beam UV-laser drilling machine: LU-2F212 (above), that can process two panels at a time

## P2C Electrical Control System Delivered to POSCO in South Korea

The P2C (Pohang No. 2 Cold Mill) electrical control system delivered to POSCO (Pohang Iron and Steel Co., Ltd.) in South Korea is a completely renewed system. The P2C is cold rolling mill for producing a variety of materials, including high-quality strip for use in automobiles. In the renewed P2C system delivered to POSCO, the combination of strip thickness control utilizing optimum control theory and a high-response hydraulic gap control system makes it possible to assure a high-quality plate thickness deviation of ± 0.4% or less for a strip entire length. In addition, new dynamic draft control technology was developed to modify the set up values for thickness and tension at odd times during cold rolling processes. Use of this technology improved the production efficiency of high strength materials, whose stand balance collapses easily, to 1.3 times the previous level.

P2C began commercial operation in April 2003; it has been operating smoothly ever since.



P2C equipment (above) and operation room showing one-person operation

# API Manufacturing Plant for Sankyo



API manufacturing plant for Sankyo Co., Ltd.

Hitachi constructed an API (active pharmaceutical ingredient) manufacturing plant for clinical trial materials for Sankyo Co., Ltd., a leading pharmaceutical company, at Hiratsuka, Kanagawa, Japan. This state-of-the-art chemical hazard API plant will produce various clinical trial materials to enable human drug development. The contract for the plant was concluded on a lump-sum basis, including equipment, piping, HVAC (heating-ventilation air conditioning) and electrical construction in February 2002. Following the construction completed in November 2003, Hitachi successfully conducted IQ (installation qualification) in January 2004.

# Solutions to Effect of Global Warming

Japan has to reduce its average national GHG (green house gas) emissions by 6% from 1990 levels to conform with the "Kyoto Protocol," during the first crediting period (2008-2012). To attain this target, "GHG management" has become more important for corporations in manufacturing industries, especially, electrical power and steel. The "Kyoto Mechanism" such as in ET (emissions trading) and overseas GHG emission reduction projects; e.g., the CDM (clean development mechanism) in developing countries and JI (joint implementation) in obligated countries, are essential to ensure continued economic prosperity. Against such a background of environmental issues, Hitachi will provide more environmentally friendly products and services to companies, municipalities, and government ministries. For example, Hitachi can provide solution menus under each process, from project design to plant system operation, through Hitachi Group technologies.

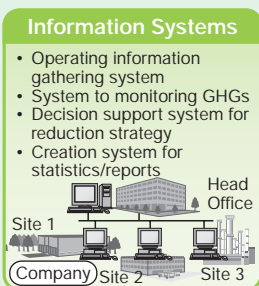
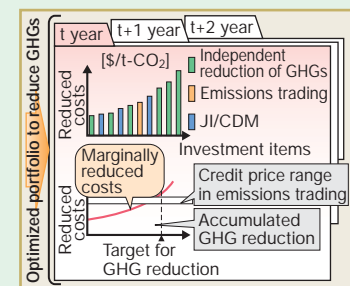
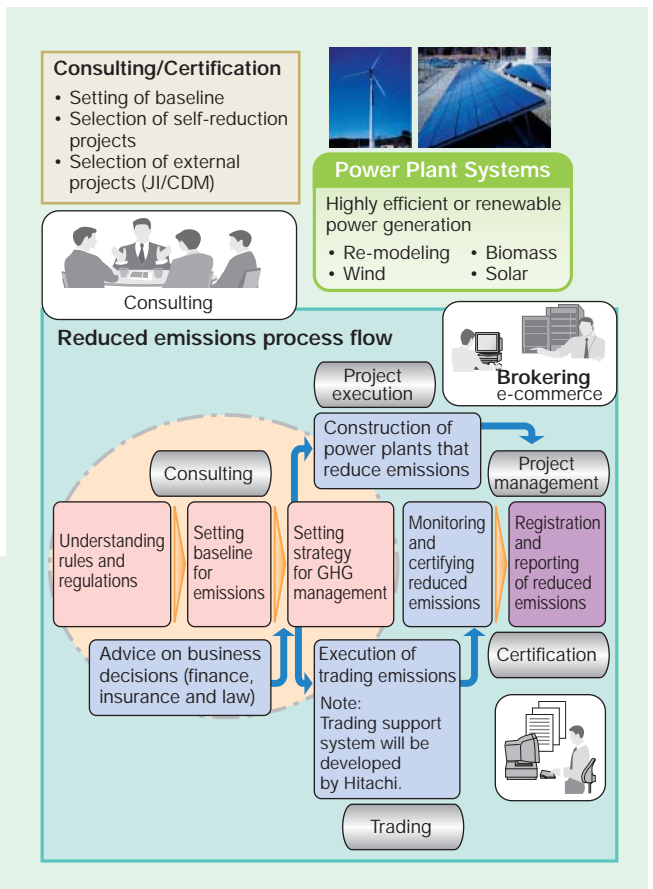

Outline of GHG management



## Hybrid Renewable Power Generation System

In recent years, several "Kyoto Protocol" ratifying countries, i.e. Japan, England and the Netherlands, have been promoting overseas GHG (green house gas) emission reduction projects, such as the CDM (clean development mechanism) and JI (joint implementation).

Moreover, as new methods of generating energy are some of the most effective ways of reducing GHG emissions, a new regulation called the RPS (renewables portfolio standard) has been introduced into environmentally advanced countries. This regulation obliges power companies to buy predetermined rates of renewable power, and renewable portfolios (a kind of "credit"), which cover the relatively expensive costs of power generation compared to fossil fuel, can be sold separately from electric power generated by renewable systems.

Based on its extensive experience with wind power generation systems, Hitachi group has selected suitable generation methods (solar, mini or micro hydro and biomass) to promote the introduction of renewable hybrid power generation systems providing a more stable power supply.

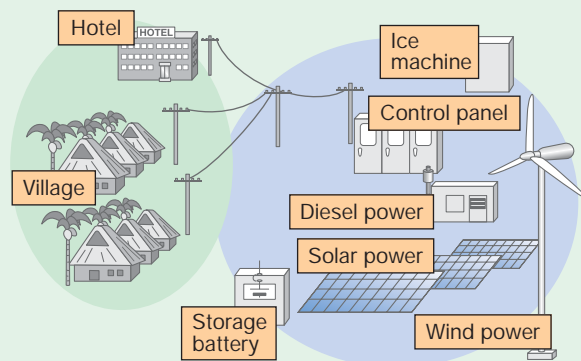

Hybrid renewable power generation system delivered to Myanmar

## Data Sharing GIS for Kochi Prefectural Government

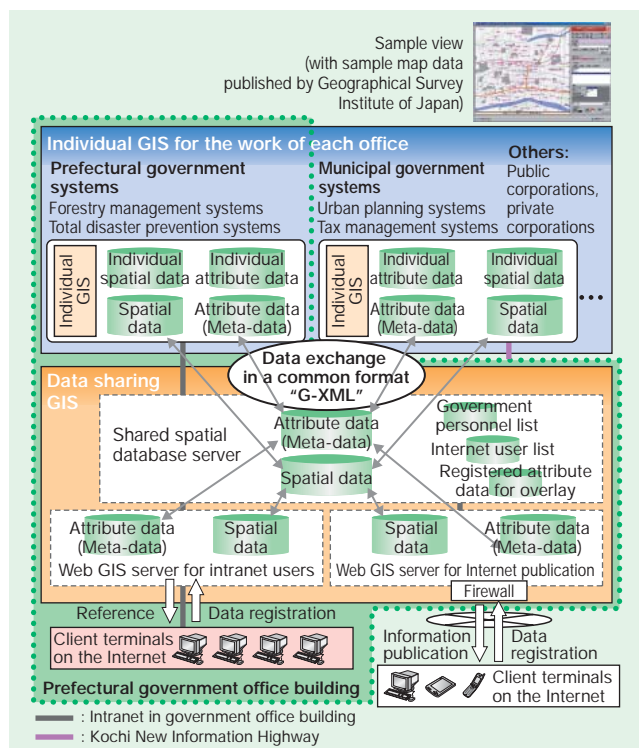

Hitachi has developed a data sharing GIS (geographic information system) that features the capability of sharing geography-related data between prefectural government offices, local agencies and municipalities in the prefecture, and its residents. The system became operational in April, 2003 for the Kochi Prefectural Government.

[Main features]

(1) The Data Sharing GIS was constructed based on a suite of Hitachi Geomatics Solutions to an integrated GIS. These were a clearinghouse, a shared spatial database, and Web GIS systems for the intranet, Internet, cell phones, and PDAs (personal digital assistants).

(2) The shared spatial database at the core of the system integrates and manages all the spatial and attribute data in the system. The database exchanges its data with local individual GIS systems in other offices in a common format, the G-XML (geospatial extensible markup language), which was standardized in Japan as a JIS (Japanese Industrial Standards) in 2002.

Sample view (above) and system overview (below) of data sharing GIS for Kochi Prefectural Government

# Mubarak Pumping Station

The monumental Mubarak Pumping Station completed in 2003 in the Arab Republic of Egypt, bringing life to the Toshka desert, has a pumping capacity of 334 m<sup>3</sup>/s with maximum lifting of 54 m to the 72.5-km long Sheikh Zayed Main Canal. After five years of construction, Aswan's main hydropower station supplies the 250 MW required for operation and water flows to the first two branches, irrigating an initial area of 10,000 acres. Egypt's hope for the 21st century has now begun. In September 1997, the Ministry of Water Resources and Irrigation of the Mechanical and Electrical Department called for proposals and bids for the design and construction of this pumping station. Out of six groups that responded the Egyptian-European-Japanese Consortium (EEJC), comprised of Kvaerner Construction, UK (now Skanska), Arabian International Construction, Egypt and Hitachi, Ltd. was awarded the bid in 1998 by getting a high point in its design proposal. Hitachi was in charge of mechanical and electrical system design for the pumping station, as well as supplying equipment, and thus played an essential role in the plans to construct it by making available its experience in the implementation of a large-capacity high-lift pump it had sub-contracted to its design consultants from Lahmeyer International of Germany and Hamza Associates of Egypt.

The main basic design elements involved the effective use of space in the pumping station, easy operation, and maintenance. Hitachi and its design consultants repeated surveys and did a hydraulic model study before moving ahead with design, eventually establishing an island type pumping station of 70-m high, 45-m wide, and 140-m long rising high above the surface of the Lake Nasser Reservoir. Total excavation reached 13.1 million m<sup>3</sup>

and 252 thousand m<sup>3</sup> of concrete was used with 36 thousand tons of reinforcement according to German standards DINs 1045 and 4227.

Hitachi supplied and commissioned all the main electromechanical equipment in the station such as 21 pumps with a rated capacity of 16.7 m<sup>3</sup>/s, 12,000-kW variable-speed synchronous motors, and all the electrical equipment systems with the central supervisory control system. These pumps were operated with the water level ranging in Lake Nasser from 147 to 178.5 m against a maximum pumping height of 201 m with variable speed control. Consequently, the water passage related to pump performance had to be newly developed to achieve high efficiency and highly stable performance across the entire flow range. As the motor was direct-driven by a variable speed drive, to minimize torque ripple, two parallel coil connections were adopted at an electrical angle of 30-degree difference, and a heat pipe cooling system was used to reduce the coolant temperature of the water. An AC exciter was adopted to achieve maintenance-free running. Hitachi's operation and monitoring system was installed to achieve optimum operating conditions with minimum power consumption for the required volume of downstream water sent from the canal management system. Extra PLCs (programmable logic controllers) were used to ensure reliable operation. Pump operation and maintenance guidance functions were also adopted to ensure stable/easy operation and maintenance of the 21-pump system.

All 21 pumps were commissioned in 2003 to irrigate the Toshka dessert. Hitachi will continue to support the operation and maintenance of the pumping station and promote research and development into irrigation systems for the deserts of Egypt.

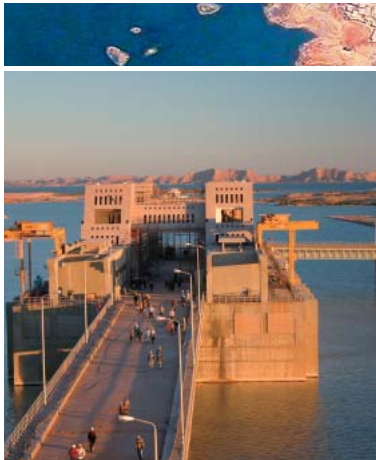

Overview of Mubarak Pump Station construction project  
The pump station was built as an island on the shore of Lake Nasser. It is located about 280 km southeast of Aswan, and about 50 km northeast of the Abu Simbel temple.



## Free-flow System: Next-generation ETC

ETC (electronic toll collection) systems currently in place use radio communications between a transponder mounted in a vehicle and an antenna mounted at the tollbooth gate to identify the road user and automatically debit the user's card so that the vehicle can pass through the tollgate without stopping. The next-generation ETC free-flow system has the added merit of allowing the road user to pass through the toll plaza without being overly concerned about the tollgate.

Ordinary road users currently pay a standardized charge on urban toll roads no matter how many sections of the road they use. In the free-flow system, ideally installed at all toll road exits, the entrance where vehicles mounted with ETC transponders accessed the toll road can be identified and their drivers will be charged a discounted toll depending on how many sections of the toll road they used. For road users who formerly paid the toll charge for the entire length of the road even though they used only one section, subscribing to the free-flow service means they will be charged only for the sections of the toll road they actually use.

The free-flow system has another feature aimed at vehicles whose drivers forget to insert their ETC card into the onboard card

unit, a function that supplements toll charging by utilizing image processing to identify the number plate of vehicles. The free-flow system thus provides a high level of dependability.

Some sections of urban toll roads in Japan have already introduced the new free-flow service. By providing the equipment used in this next-generation ETC system, Hitachi, Ltd. is contributing to alleviating traffic congestion, reducing the generation of CO<sub>2</sub>, and lowering toll charges.

At present, Japan's Ministry of Land, Infrastructure and Transport is promoting the concept of "smart interchanges" as it aims to lower the cost of interchanges. The Tokyo Metropolitan government, meanwhile, is planning to introduce an "environmental road pricing system" for management of vehicles that enter the Tokyo city limits. It is expected that more and more onboard equipment for vehicles utilizing the ETC system will be used in the future. The demand for the free-flow system is also expected to increase proportionately.

Hitachi has promoted the development of wide-ranging technologies after concluding that the free-flow system will eventually enjoy widespread use.



Equipment for free-flow system installed on test course (above left), and exit lane of Metropolitan Expressway in Tokyo (below right)

# Location System for Tobu Buses

Tobu Bus introduced a location system for buses on routes assigned by its Nishiarai branch in April, 2002. Hitachi delivered the whole system including 17 onboard controllers that transmit information on present bus locations to a central system via a digital packet radio network. The central system collects location information from all running buses and distributes this to 26 bus stops in the vicinity, which display the locations of approaching buses.

The advantage of a bus-location system for passengers is that they can see the locations of arriving buses while waiting to decrease irritation. The advantage for bus operators, on the other hand, is that they can monitor bus locations at the center and change scheduled bus operations temporarily if necessary. For example, if the operator estimates the bus will be late at the depot because of traffic congestion and will continue to be behind schedule, he can dispatch another to maintain services. Also, bus operators can make use of their running records to plan better time tables and operation schedules.

Hitachi has other references for bus location systems in Asahikawa, Nagoya, and Toyohashi and for systems to monitor moving fire engines, police cars, taxis and trucks using radio networks. The bus-location system is one of Hitachi's tracing solutions provided by radio.

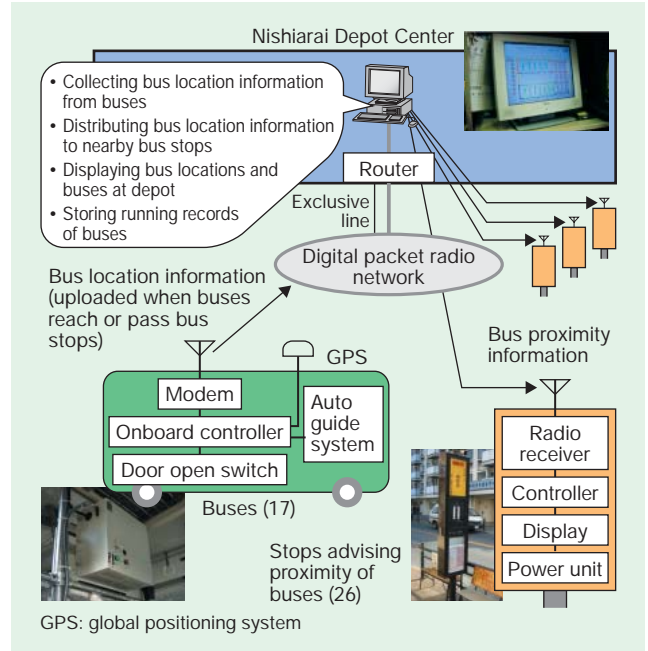

System configuration of bus-location system introduced to Tobu Bus' Nishiarai branch

# IPv6 Network Solutions

Hitachi's IPv6 solutions are based on its capabilities, experience, and know-how in developing the network and its advanced IPv6 products. It can be used in various applications as an ITS (intelligent transport systems) network platform, and Hitachi began

to evaluate its conformity to the specifications set by the Internet ITS Consortium in September 2003. Hitachi's IPv6 network solutions represent a smooth transition from IPv4 and provide high-level security functions that will satisfy customer needs.

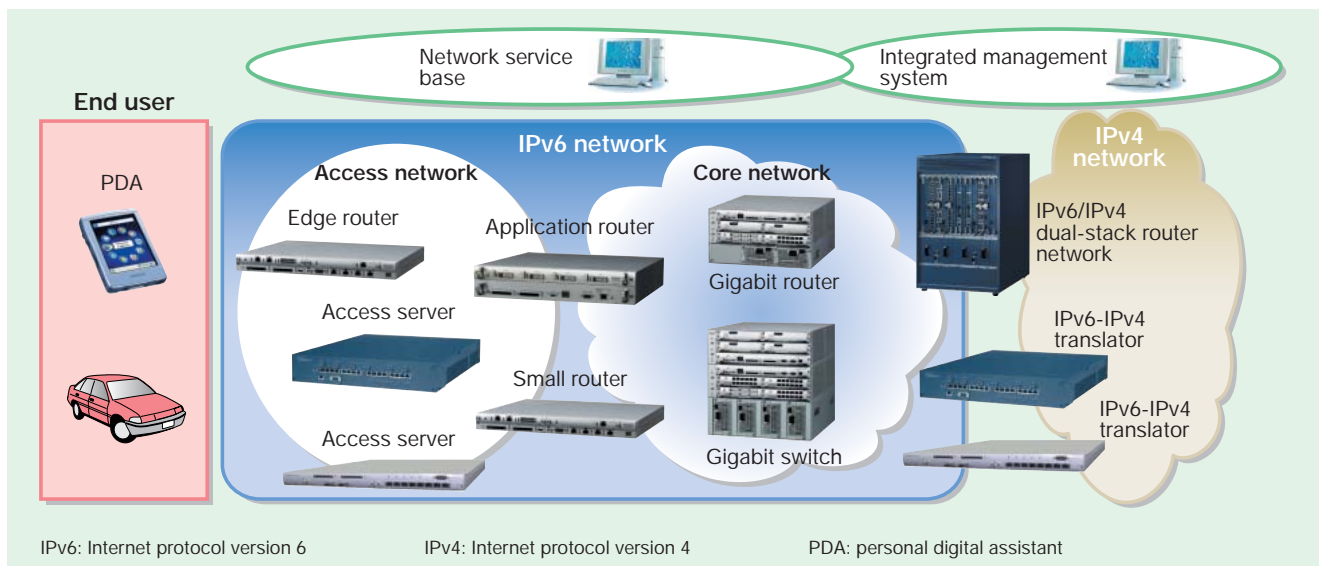

IPv6: Internet protocol version 6

IPv4: Internet protocol version 4

PDA: personal digital assistant

IPv6 network solutions



## System for Providing Traffic Information

After Japan's Road Transport Law was revised in June 2002, it became possible for private businesses to collect road traffic information on their own, process it, and provide information services to customers.

Hitachi, Ltd. already has much experience in collecting road traffic information and providing it to prefectural police offices. In order to provide even more reliable road traffic information in the future, Hitachi has developed a method of forecasting highly accurate trip times based on a statistical database comprised of past road traffic data categorized into various types of days, such as Sundays, holidays, and special seasonal days. Various needs exist for the forecast of highly accurate trip times to destinations, based on date and time-of-day information, such as for parcel delivery services that must schedule deliveries and providers of contents for car navigation equipment and mobile phones. At present, technology that Hitachi has developed for forecasting traffic congestion is being used to provide traffic congestion forecast services for mobile phone users.

Hitachi is also developing a system that will make it possible to provide highly accurate wide-area traffic information by using probe information to supplement other traffic information at locations where there are no sensors for collecting road traffic data.

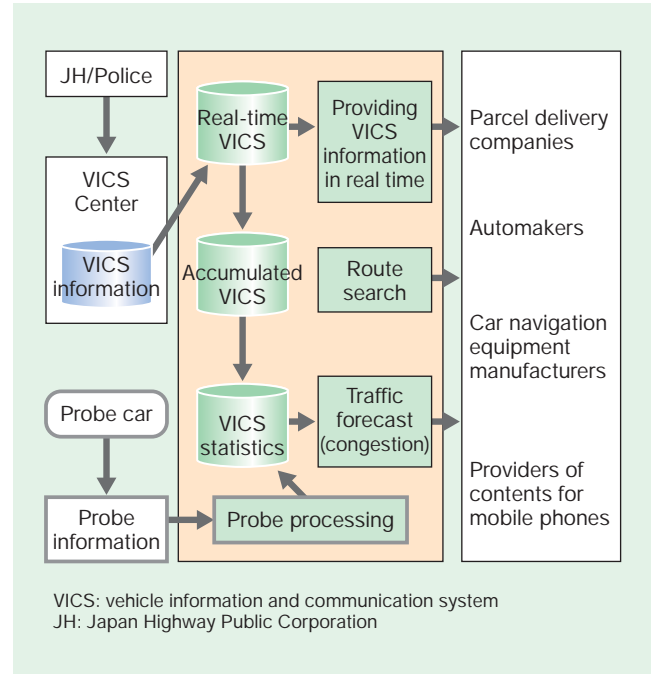

System for providing traffic information

## 100-kW Motor and Inverter for Super Strong HEV

The HEV (hybrid electric vehicle)'s series-parallel motor and inverter, aimed at preventing global warming and reducing CO<sub>2</sub> emissions, have been newly developed to provide a unique driving experience.

[Main features]

Motor

- (1) Max. torque: 225 Nm
- (2) Max. power: 100 kW 1 min rated
- (3) Max. speed: 12,000 r/min
- (4) Weight: 62 kg

Generator

- (1) Rated power: 30 kW /2,500 r/min
- (2) Weight: 35 kg

Inverter

- (1) Max. capacity: 60 kVA
- (2) Weight: 32 kg

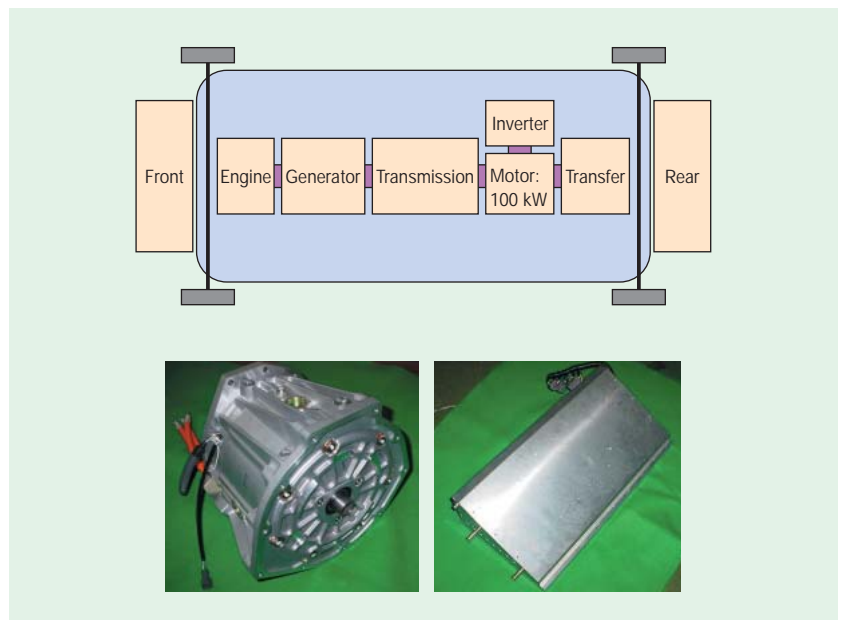

HEV configuration (above) and newly developed motor (below left) and inverter (below right)

## Millimeter-wave Radar for Subaru ADA System

Subaru adopted Hitachi's 76-GHz millimeter-wave radar for their 2003 Legacy Touring Wagon 3.0R. This is used as an intelligent sensor combined with a stereo camera for their ADA (active driving assist) system to measure the distance, relative speed, and azimuth of the target vehicle(s). The ADA system supports safe driving through various functions such as ACC (adaptive cruise control) and LDW (lane departure warning).

[Main features of Hitachi radar]

(1) It is small, inexpensive and highly reliable due to the following technologies.

(a) Monopulse technology, which uses two receiving antennas to detect the azimuth of the target without any moving (scanning) mechanisms.

(b) A 76-GHz frequency band MMIC (microwave monolithic integrated circuit) chip set, which was designed for the 0.15  $\mu\text{m}$ -gate GaAs-based PHEMT (pseudomorphic high-electron-mobility transistor) process.

(2) Very close (from 1 m) detection capability by FSK (frequency shift keying) modulation, which is suitable for "stop and go" applications as well as ACC.

(3) Improved "zero doppler" performance to achieve smart and comfortable ACC.

Millimeter-wave radar is expected to be a key sensor for ADAS (advanced driver assistance systems) functions such as "pre-crash detection" and "blind spot detection" as well as "ACC" and "stop and go."



Subaru Legacy Touring Wagon 3.0R with ADA system (above) and Hitachi millimeter-wave radar (below)

## Low-cost Automatic Transmission System with AT Shift Feeling and MT Fuel Economy

AMT (Automated manual transmission) is being put to practical use with the tightening fuel efficiency requirements for automobiles, particularly in Europe. AMT has fuel efficiency that exceeds that of MT (manual transmission) by automating shifting. However, it suffers from torque interruption during shifting. Therefore, many companies are developing next-generation AMT systems. One of these next-generation AMT systems is "Twin Clutch AMT," which transmits torque just like conventional AT during shifting. At the same time, Hitachi is developing another next-generation AMT called the "Torque Assist AMT," which completely differs in structure and principle compared with the Twin Clutch AMT. It consists of a conventional MT frame and a new torque transfer mechanism, which is called an "Assist Clutch" to transmit torque to the wheels during shifting. The Assist Clutch is attached to the existing MT section, without the need to change its frame. The Torque Assist AMT therefore satisfies all the following. It is cheaper and more fuel efficient than MT and has shifting quality approaching conventional AT. Because of this, the Torque Assist AMT is especially suitable for small front-wheel-drive vehicles.

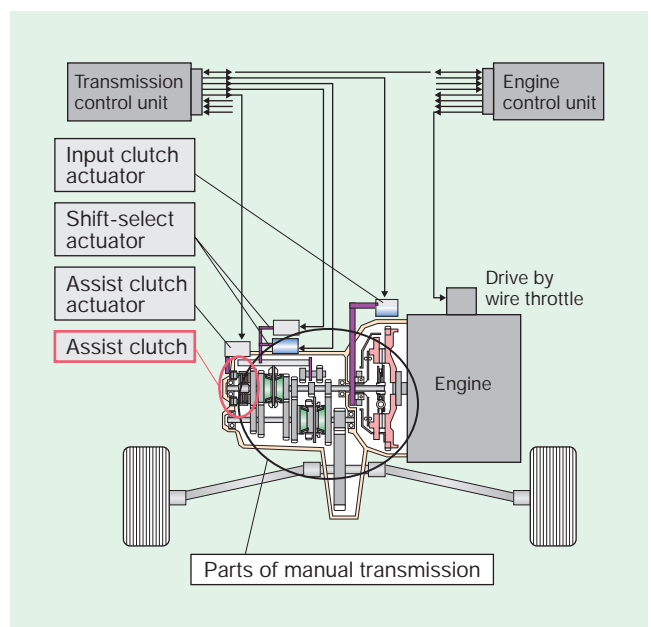

Torque assist automated manual transmission system



## High-pressure Fuel Pump for Direct Injection Gasoline Engine

The direct injection system is the most effective method of reducing CO<sub>2</sub> emissions in gasoline engines, and is expected to become widely used around the world. The high-pressure fuel pump is one of its main components. Hitachi has developed a single cylinder pump directly driven by the engine camshaft, which makes it possible to reduce engine consumption energy-loss through variable flow rate control. This pump only supplies fuel in response to fuel being consumed by the engine.

It has a large degree of freedom for mounting on engines due to its low height design and light weight achieved by adopting an aluminum body.



High-pressure fuel pump for direct injection gasoline engine

## Series 800 Shinkansen for Kyushu Railway Company



Nose of Series 800 Shinkansen

In March 2004, the Series 800 Shinkansen (bullet train) started its passenger service on the Kyushu Shinkansen line, operated by the Kyushu Railway Company. All of the five train sets (six cars for each train set) of the Series 800 Shinkansen were manufactured by Hitachi.

Although the Series 800 Shinkansen is technologically based on the Series 700 Shinkansen, developed by the Central Japan Railway Company and the West Japan Railway Company, Hitachi added some new features to this new train.

For example, the front of the Series 800 was designed on Hitachi's nose shape optimization theory (three-stage paraboloid) to reduce micro-pressure waves. External train nose was reduced and stability was improved, verified in wind tunnel tests and through CFD (computational fluid dynamics).

Also, its interior was redesigned to express the Japanese appreciation of nature in innovative ways, such as employing natural wood for the passenger seats and interior walls.

## Okinawa Urban Monorail

The Okinawa urban monorail (known as Yui-rail), which started services in August 2003, is the first post-war railway traffic system in the prefecture.

Hitachi supplied key components for the system including the vehicle (body, bogies, air conditioners, and on-board electrical equipment), ATS (automatic train supervisory system), SCADA (supervisory control and data acquisition), PGS (platform gates system), communications, power substation, and track switches.

[Main features]

(1) Passenger demand requires the train to have a two-car configuration, which severely strained equipment allocation in the limited space at the front.

(2) The platform gate door effectively assists the driver's task and enhances passenger safety.

(3) A simplified computer system for ATS and SCADA

(4) Vehicle and the control room were designed to fully harmonize with Okinawan tradition and the environment.



Okinawa urban monorail ("Yui-rail")

## Tsukuba Express Dual-voltage AC/DC Electric Trains for Metropolitan Intercity Railway Company

Dual-voltage AC/DC electric trains are being built for the 58.3-km Tsukuba Express route from Akihabara to Tsukuba, which is scheduled to open in autumn 2005.

The trains are formed of six cars, and have a maximum speed of 130 km/h on lines without grade crossings. Two cars on each train have transverse seating bays, while the remaining four cars have longitudinal seating. The trains were built based on Hitachi's "A-train" concept, with unpainted aluminum vehicle bodies used to ensure light weight, high recyclability, and reduced environmental load. State-of-the-art FSW (friction stir welding) is used to achieve aesthetically pleasing vehicle bodies with minimum distortion.

Extensive modularization of components reduces the number installed, and simplifies assembly.

The control systems use the latest converter and inverter equipment to ensure high performance, energy savings, and reduced maintenance.



Tsukuba Express dual-voltage AC/DC electric trains



## Finger Vein Attester System

Finger vein verification is a powerful biometric personal identification technology. The finger vein pattern is different for each person. Hitachi therefore used this human trait as the key to the access control system.

[Main features]

- (1) Highly secure: It is difficult to fake or steal samples of finger veins because it uses human characteristics that exist inside the body.
- (2) Highly acceptable: It is smooth and user friendly. Verification does not depend on finger surface status such as grime, dryness, or sweatiness.
- (3) Hygienic: The finger vein scanner has a non-contact sensor. Therefore, attesting is clean compared with finger print verification.

Finger vein verification system is not only stand-alone but can also have a network configuration through an Ethernet LAN connection to manage the access of buildings/offices. It adopts the combination of an ID number and finger vein verification as 1:1 recognition in systems with over 100 users. However, finger

vein verification can be used as 1:N recognition in systems with less than 100 users. For the purpose of access control, Hitachi can provide software which manages personal data, history records, scheduling, and door/gate status.

An application for finger vein verification provides high security gate clearance systems for buildings, banks, universities and laboratories.

Finger vein verification can also provide combined IC card systems to strengthen existing security systems.



Finger vein scanner detecting the finger vein pattern

## Hitachi IT Condominium System and Services Networked by Hitachi Customer Center

Hitachi installed IT Condominium System to provide various kinds of services by connecting a home server in each residence and a condominium controller with the Hitachi Customer Center to Soleil Esaka (Osaka).

The main features of Soleil Esaka are as follows.

High-quality security services are achieved such as locking/unlocking with electronic keys and operating elevators with an IC card with personal identification capabilities. Useful information is also confirmed through an IT board and conve-

nient services are provided by mobile phone.

In addition, Hitachi opened an IT Condominium Showroom in Guangzhou, and will open more in Beijing, and Shanghai to demonstrate its system to marketing hubs to help establish bases of business for integrated management of condominiums and buildings in China.

[Completion dates of Showrooms]

Guangzhou: Oct. 2003

Beijing and Shanghai: July, Oct. 2004

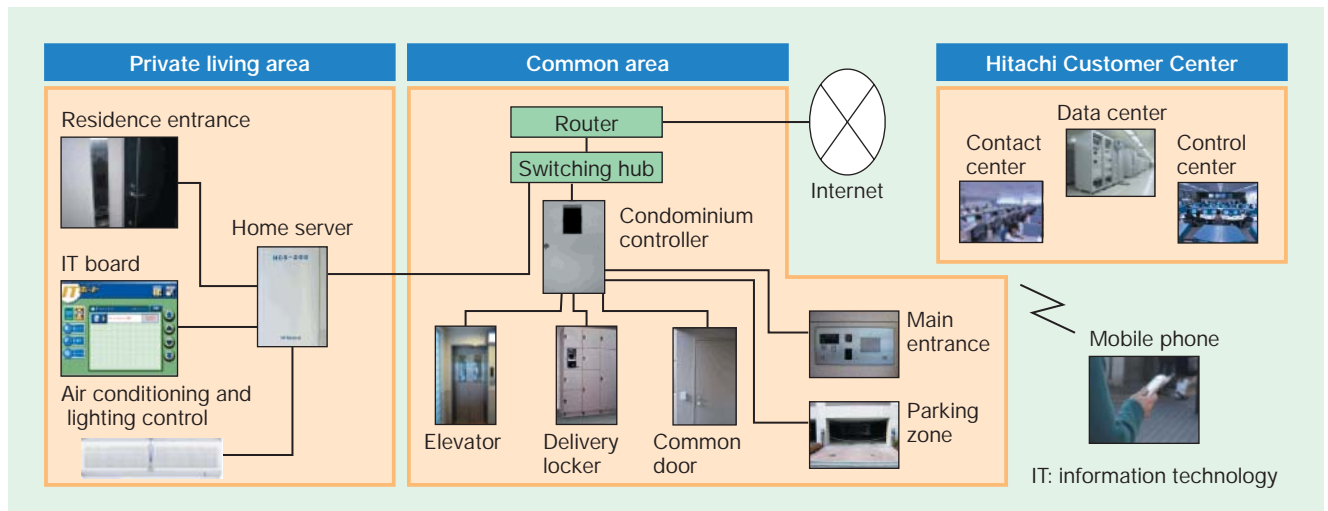

IT Condominium System

## Release of Built-in Station Platform Elevators for Easier Station Accessibility

Hitachi has launched a new model of built-in station platform elevators. This elevator drastically reduces the installation period and has a Universal Design enabling convenient use of the station.

[Main features]

(1) Universal Design

- (a) 50-mm diameter hall button that is easy to press and see
- (b) 10-mm gap between sill to sill and 10-mm sill groove reduce the anxiety of passengers when getting on and off.

(2) Space saving

- (a) Pit depth reduced to 750 mm, which enables easy installation in the station platform.
- (b) Through opening and corner opening models will allow ease of getting on and off the elevator.

(3) Reduced installation period

By manufacturing elevator and hoistway in the factory, the installation period can be reduced to 2 weeks.



Sill design (left) and car design (right)



## 99 Moving Sidewalks for Thailand Suvarnabhumi International Airport

Siam-Hitachi Elevator Co., Ltd., Hitachi's elevator and escalator sales and manufacturing company for the Southeast Asian region, will supply 99 moving sidewalks for the Suvarnabhumi International Airport, which is being built by the New Bangkok International Airport Company Limited (NBIA).

Hitachi and Siam-Hitachi Elevator are aiming to provide delivery in November 2004.

The order is for 66 units of the 1600 series (1,600 mm nominal effective width) and 33 units of the 1200 series (1,200 mm nominal effective width). These moving sidewalks will be used in the concourse building. The total length of the 99 moving sidewalks is about 6,400 m, and 4 units of these have overall lengths of 108 m.



Location of Thailand Suvarnabhumi International Airport (left) and expected view of airport (above)



## High-throughput High-resolution Computer-controlled Transmission Electron Microscope

The H-9500 300-kV TEM (transmission electron microscope) was developed by Hitachi to fulfill the demanding requirements of today's scientific community where the atomic resolution of new materials, such as semiconductors and nanoparticles, is of paramount importance.

The H-9500 utilizes Hitachi's proven high-voltage technology and incorporates modern computer control, a new GUI, and a fully integrated digital camera for image processing and archiving. A convenient automatic startup mode enables a stable 300-kV beam to be established in under five minutes. Specimen exchange can be completed in under one minute. An FIB (focused ion beam) compatible holder allows samples to be prepared in it and then transferred directly into the H-9500.



H-9500 transmission electron microscope

## H-7650 Digital Transmission Electron Microscope

A new 120-kV PC (personal computer) controlled TEM (transmission electron microscope), the H-7650, has been developed to increase efficiency in biomedical applications. Two operating modes, "HC (high contrast)" and "HR (high resolution)," are available. The HC mode is used for observation at higher contrast under a wider field of view and the HR mode is for higher image resolution. Four stages for the image-forming lenses allow a magnification range of 50× to 600,000× with compensated image rotation.

A model ER-B\* digital camera is integrated with the TEM displaying images at 16 frames per second and storing 1,024 × 1,024 pixels of 12-bit-depth images. Acquired images are displayed on a PC monitor and also input into an image processing unit to automate focusing and correct astigmatism. As the ER-B camera has 40 times higher sensitivity than photographic film, digital images can efficiently be obtained in "low dose" applications. Several operating-software functions have been newly developed to enhance the advantage of digital images. The auto-photo adjusts image focus and saves the image with one click. The digital auto-multi-frame (montage) function acquires the sequence of digital images to expand the field of view and multiply the number of pixels.

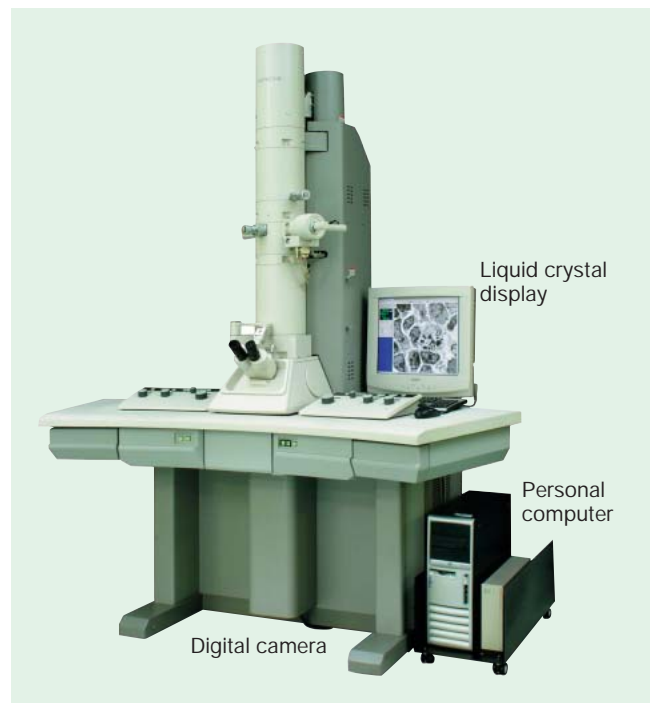

H-7650 digital transmission electron microscope

\* Model name of Advanced Microscopy Techniques Corporation, USA

## Multi Slice X-ray CT Device

Hitachi has developed x-ray CT (computed tomography) equipment that uses a newly developed high-speed computer-processing unit to calculate image data 0.2 seconds after scanning.

Together with the shift from single slice to multi slices of image data taken of the body using narrow x-ray beams, CT images today are comprised of much thinner multi slices. At this x-ray CT device's pitch 7 (table moved at 7× slice thickness), scans of a patient's stomach area are possible while holding his/her breath just one time. High-speed scanning at pitch 7 and image computing in 0.2 seconds are particular effective for obtaining images of the stomach area and large blood vessels. Since CT scanning and imaging display progress in parallel, the efficiency of the workflow from diagnosis to treatment is improved. Conversion from BMP (bit map) images to JPEG (Joint Photographic Experts Group) images is also readily accomplished, and accessibility to the CT images has been raised by a network connection function for PCs in clinics and hospitals.



Exterior view of multi slice x-ray CT device

## Partire System Fitted with Wide-vision FPD for Exclusive Use in IVR: SX-VA3000

SX-VA3000 fitted with a wide-vision FPD (flat panel detector), is comprised of an examination table and a device for attachment to the ceiling for holding a C-arm. It is most appropriate for IVR (interventional radiology) of the head or abdomen. The FPD has a wide 40 × 30-cm viewing area and high contrast. It thus provides high-quality real-time DSA (digital subtraction angiography) images not previously possible. Positioning is much easier, and fewer examinations are required. Overall radiation exposure is thus reduced, less contrast medium is needed, and great positive effects are realized by reducing examination time. Also, since the image-processing unit makes maximum use of the wide-vision and high-contrast functions of the FPD, automatic maximizing of the dynamic range compression processing and the display contrast (gradient) is applied to the fluoroscopic image and the projected image, thus considerably upgrading the visibility of the catheter. In order to maximize the fluoroscopic and scanning conditions, moreover, new algorithms were developed and loaded to the system.



Examination table and device for attachment to ceiling and holding C-arm



## ASP Service Supporting Stage from “Aha!” to Invention

Hitachi launched an ASP service for researchers who are on the frontiers of high technology. The service is a fast and easy-to-use patent data mining system combining Japanese and U.S. patent data with a high performance associative-search engine GETA\*1 developed through collaboration with NII (National Institute of Informatics) under the auspices of the IPA (Information-technology Promotion Agency) of Japan\*2.

The service enables (1) researchers to collect target patent entries based on written similarities by using not only key words but also multiple sentences as queries, and (2) it provides client software, displaying the patent-title list on the left and topic words graphically on the right.

A part of a manuscript, even half-finished, can be used as a query to search relevant patent entries to check for originality. Trends in technologies can be analyzed through patent data by searching with selected topic words presented in the right window, even if there were no hits on the right key word set.

This ASP service is a powerful tool to support the process from the idea to the right, including the realization of “Aha!” and strategy building for patent mapping.

\*1 <http://geta.ex.nii.ac.jp/>

\*2 <http://www.ipa.go.jp/>

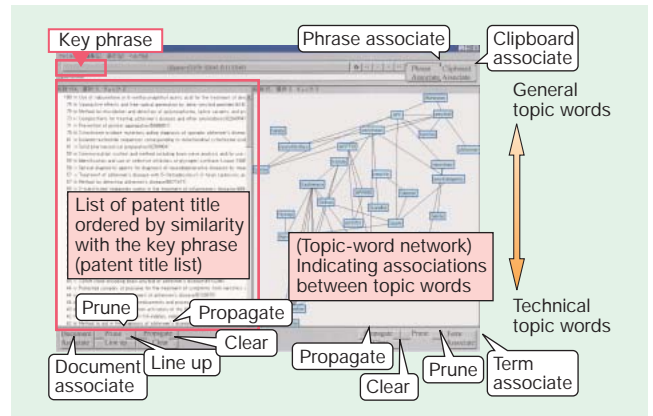

ASP service interface

List of patent titles ordered by similarity with key phrase (patent title list)

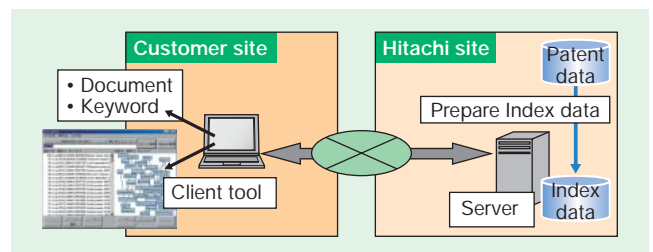

System organization for ASP service

## U-7000 Vacuum Ultraviolet Spectrophotometer

The U-7000 vacuum ultraviolet spectrophotometer corresponds to evaluations of needs in optical characteristics, which indicate a rise in the oscillation wavelength (157 nm) of F<sub>2</sub> lasers, a stepper light source to be used in next-generation semiconductor lithography. The U-7000 has a 130–380-nm measurement wavelength region, corresponding to i-line (365 nm), KrF-eximer (248 nm), ArF-eximer (193 nm), and F<sub>2</sub> stepper applications. It can easily produce high-throughput measurement through a sample turret mechanism that enables simultaneous and precise measurement of five or more samples. More precise and high-throughput measurement is available with the photo multiplier's differential-feedback system unique to Hitachi. The sample compartment and a monochromator are formed into one unit, corresponding to an optimal compartment for the user's unique sample. Valuable data with a selectable optical band path (0.5 to 8 nm) can broaden the user's analysis of the substance's features. The U-7000's unique exhaust system enables two different measurement conditions to be selected, vacuum and nitrogen purged. Vacuum conditions achieve high-throughput measurement while nitrogen purging provides an extremely clean sample compartment that prevents the sample from becoming contaminated.



U-7000 vacuum ultraviolet spectrophotometer

## High-resolution CD-measurement SEM: S-9380

Hitachi completed the development of the S-9380 high resolution CD (critical dimension)-measurement SEM (scanning electron microscope) which is compatible with 300-mm wafer at 65-nm process node.

The S-9380 has improved reliable hardware and software and allows a high throughput of 24 wafers per hour at 20 point measurements per wafer with a high imaging resolution of 2 nm or better. The S-9380 has an automated column alignment which has eliminated the conventional need for experienced operators. In addition, it minimizes measurement errors associated with individual operator's skills. It also offers long-term stability in highly precise CD-measurements.

Hitachi improved the accuracy of wafer alignment in the auto-measurement mode with the S-9380, addressing specific measurement points, auto-focusing, and image recognition of measurement patterns compared to its previous models. Due to these, the S-9380 has achieved a high success rate during automated measurement. The S-9380 is compatible with new materials and solves associated problems such as resist shrinkage and wafer charging. It has exclusive application software to control optical doses and focus of steppers. It also permits processed patterns to be evaluated, allowing detection of fine process variations in real time. Detected data can be fed back to processing lines to correct for variations. The S-9380 has a SEMI standard GEM 300 or S2-09 incorporated, which allows problem-free networking at users.

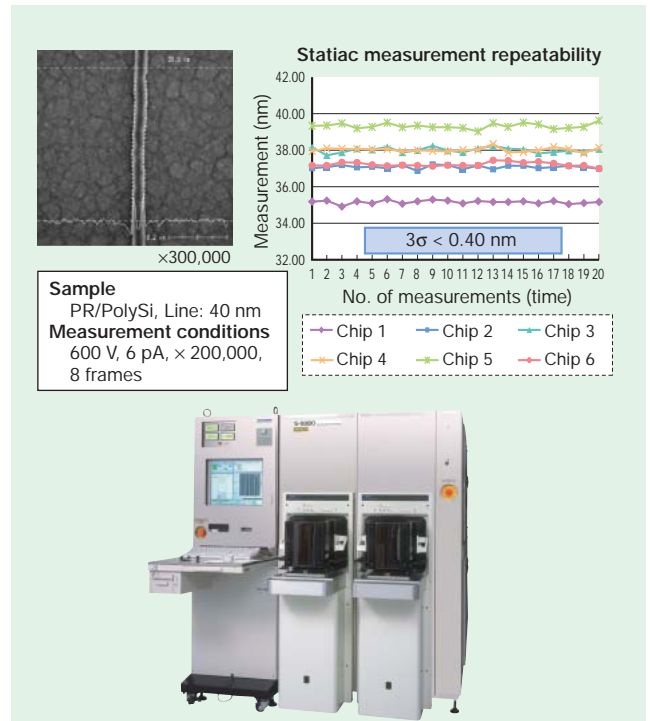

Measured sample, static measurement repeatability (above) and appearance of S-9380 (below)

## In-line Defect Review SEM: RS-3000 V5

The RS-3000 V5 is an in-line defect review SEM aimed for use in leading-edge semiconductor technologies.

Higher circuit integration and increased density in semiconductor devices, e.g. 90-nm process node, require quick, efficient detection and subsequent review of fatal defects. Hitachi has completed the development of the RS-3000 V5 in-line defect review SEM to enable fatal defects to be efficiently reviewed.

The RS-3000 V5 has an enhanced function that acquires 4 sets of images simultaneously. These images include a secondary electron image, left and right oblique images, and a voltage contrast image. In addition, the system includes ADR (automatic defect review) and ADC (automatic defect classification), which have been designed for improved performance, reliability and repeatability. Other features include review of defects in bare wafers, EDS (energy dispersive x-ray spectroscopy) for x-ray microanalysis, and a fixed-point observation mode for monitoring fluctuations during wafer processing.

When the RS-3000 V5 is used in conjunction with the RI-1000 review support system, the combined system is an extremely powerful tool for providing an understanding of defect modes and trends in wafer processing.



RS-3000 V5 in-line defect review SEM



## Gate Plasma Etching System with APC Techniques

Hitachi has developed a gate plasma etching system with APC (advanced process control) techniques. This system provides highly advanced etching of gate electrodes beyond 0.13 μm geometries through CD (critical dimension) control based on Hitachi's original APC techniques.

[Main features]

(1) Micro-fabrication with Hitachi's original method of CD control

This system aims at allowable CD change of less than 3 nm with single continuous etching from the resist layer (resist trimming) to the poly-silicon layer using *in-situ* thickness/depth monitors, an *in-situ* CD trim monitor, and "Run-to-Run Control."

(2) OEE (overall equipment efficiency) improved  
The purpose of an analysis and diagnosis system for APC is to improve the uptime ratio of etching systems, such as shortened TAT (turn-around time), reduced NPW (non-product wafer), and shortened MTTR (mean time to repair). It is also to reduce costs, maintenance time, and to prevent failures in etching systems.

(3) Highly advanced etching of 300-mm wafers  
High accuracy, such as that required to produce

highly uniform isolated and dense patterns and negative and positive patterns in wafers, can be produced with the U-712, a gate plasma etching system, and the APC system.

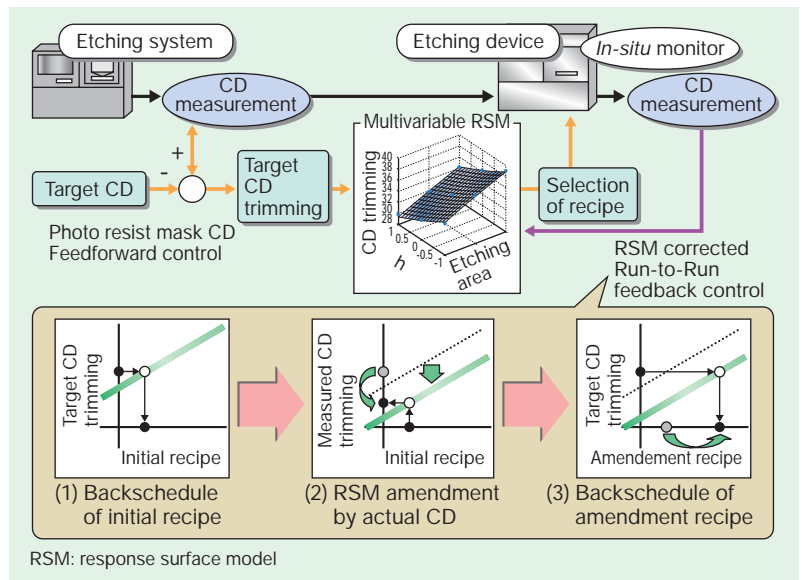

RSM: response surface model  
Concept of APC techniques with "Run-to-Run Control"

## Highly sensitive, High-speed, Dark-field Wafer-inspection System

The use of copper interconnections, high- or low-dielectric-constant materials, and new processes such as planarization by CMP (chemical-mechanical polishing) is steadily complicating



Highly sensitive, high-speed, dark-field wafer-inspection system: IS2700E

semiconductor fabrication processing. Under these circumstances, it is important to improve or maintain process yield in the early stages of line start-up by detecting particles and defects that occur during processing and promptly remedying them. Hitachi Group made it possible to conduct high-speed, high-sensitivity monitoring of defects and particles produced by beyond-65-nm-node processes by developing and installing the IS2700E dark-field inspection system for patterned wafers on the production line. The IS2700E made it possible to detect defects, such as particles, scratches, pattern short circuits, and cracks, on patterned wafers with a sensitivity of 0.07 μm. It can inspect all product wafers 300 mm in diameter at high speed, i.e. a throughput of 37 wph (wafers per hour). In addition, its user-friendly operation makes recipe creation easy, and it is equipped with an interface that provides defect analysis functions, automatic DFC (dark-field classification), and analysis through a high-resolution DUV (deep ultraviolet) defect-review optical system and SEM (scanning electron microscope) defect data link.

[Main features]

- (1) Highly sensitive, high-speed inspection at low cost of ownership
- (2) Dark-field real-time defect classification function
- (3) Ease of use

## Formation of Nanopillar Structure by Nanoprint Technology

Nanoprint technology is a new technique used to fabricate nano-scale patterns. These patterns are formed by applying a mold with correspondent nano-scale patterns onto the material to be nanoprinted. Nanopillar structures made in polymer materials with 100 – 250 nm diameters and 1 – 3  $\mu\text{m}$  heights were fabricated by nanoprint technology for the first time. The nanopillar sheets have been shipped as a new biomaterials for several uses. For example, Hitachi has exhibited a nanopillar chip for immune assay. The surface density of biomolecules on the chip is increased by the formation of nanopillars. A nanoimprint machine will also be sold; Hitachi has demonstrated nanoprinting on the entire 300 mm Si wafer. Nanoprint can be applied to boundless fields taking advantages of its high-resolution and simple process. Hitachi intends to expand the nanoprint business to medicines, cosmetics, electronic manufactures, and automobiles by offering total nanoprint solutions. Hitachi expects nanoprint technology as the nano-scale fabrication infrastructure for next generation.

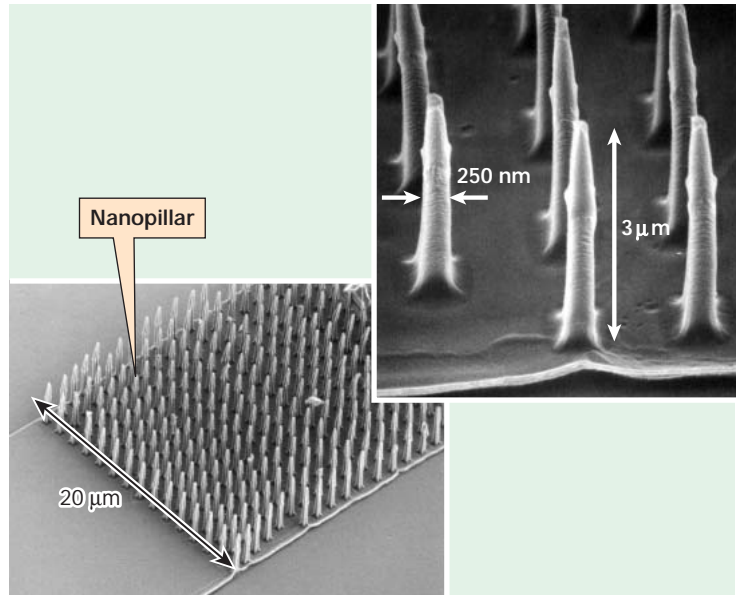

SEM (scanning electron microscope) images of nanopillar structure

## 2-kV Static Induction Transistor in 4H-SiC Technology

Hitachi developed a static induction transistor<sup>1)</sup> using a single crystal silicon carbide substrate material (SiC). Its features are: (1) The current path is in a perfectly vertical channel without internal lateral gates, and (2) the source and gate are overlapped. It is the most suitable structure and reduces the size of devices as a result. The newly designed chip was laid out with 4,486 units with a unit cell pitch of 10  $\mu\text{m}$ . Measured results were a drain current of 5A and the specific on-resistance of 15  $\text{m}\Omega\cdot\text{cm}^2$ . Therefore it is proved that on-resistance in a 2-kV-class device could be reduced to 1/60 or less compared with conventional silicon power devices. Greater miniaturization and reduced losses are expected by applying these technologies to power electronics equipment, such as electric vehicles, information terminals, and consumer products.

This development was carried out in response to a commission by NEDO (New Energy and Industrial Technology Development Organization).

1) J. Nishizawa, et al.: Field-effect Transistor versus Analog Transistor (Static Induction Transistor), IEEE Trans. on Electron Devices, ED-22, pp. 185-197, 1975

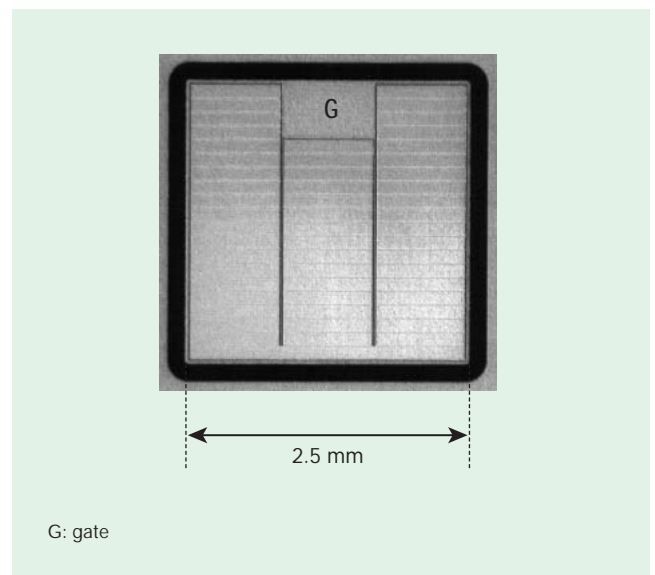

Top view of 2.5  $\times$  2.5 mm fabricated chip, consisting of 4,486 unit cells



## High-porosity Cordierite Diesel Particulate Filter for Commercial Vehicles

Hitachi Metals, Ltd. developed a large monolithic-structure high-porosity cordierite filter to reduce PM (particulate matter) emissions in commercial vehicles, and have been mass-producing these since fall 2003.

Diesel particulate filter systems for commercial vehicles require low pressure and efficient filtration because PM emissions and fuel consumption need to be reduced. Hitachi realized such filtration by optimizing the honeycomb structure and porous-wall microstructure. The new filter developed achieves both low pressure and high filtration efficiency, which are usually a tradeoff. Hitachi also made technological innovations in manufacturing, and was the first in the world to produce large, high-porosity filters for heavy-duty diesel vehicles.

[Main features]

- (1) Porous-wall thickness: about 0.3 mm
- (2) Cell density: about 0.63/mm<sup>2</sup>
- (3) Porosity: between 63% and 68%
- (4) Mean pore size: about 0.02 mm
- (5) Efficiency to filter soot: more than 95 mass % over a wide range
- (6) Standard monolithic structure: a 266.7-mm diameter and 304.8-mm length

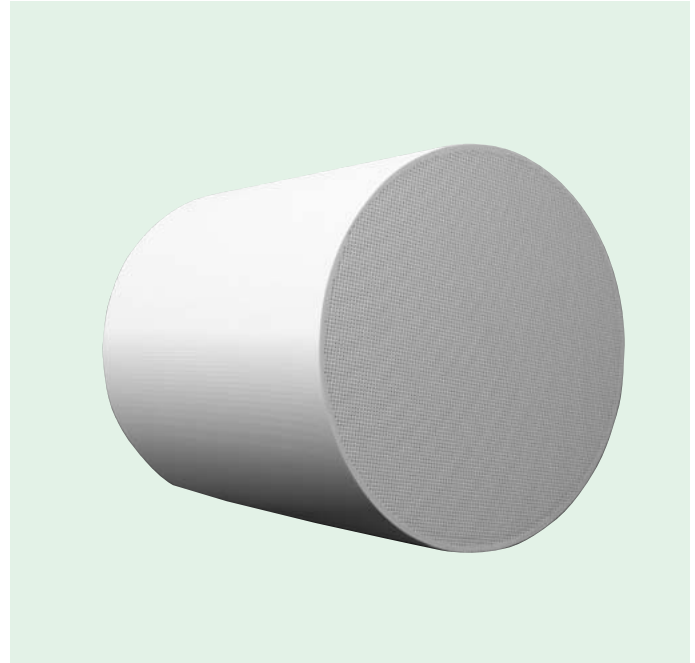

High-porosity cordierite filter for heavy-duty diesel vehicles

## New High-performance 3-axis Accelerometer

3-axis piezo-resistive accelerometers "H48A/B," produced by the MEMS (micro-electromechanical system) process, were introduced by Hitachi Metals, Ltd. in 2001. They were the first commercially available tri-axial accelerometers in the world. They feature simultaneous detection in 3D of "tilting," "vibration" and "acceleration," while the package is the smallest [4.8 × 4.8 × 1.25 (mm)] in the industry. In 2004, the H48A/B will evolve onto the market as the H48C. It is more reliable and functional than the current models. It is equipped with several new functions such as an analog pre-amplifier and calibration for variations with temperature in "sensitivity" and "offset drift." "Free fall flag" can also be hoisted if an instrument with the H48C installed falls down. It is highly resistant to shock, reliable against shocks up to 5,000 G. The H48C is an innovative accelerometer with the same footprint as the H48A/B. The H48C is expected to open doors to numerous non-traditional applications, across a host of potential markets, from airbag systems to video games and handheld devices such as PDAs (personal digital assistants).



New accelerometer: H48C (4.8 mm<sup>2</sup> × 1.5 mm thick)

Parameter	Unit	Current model (H48B)	New model (H48C)
Operating voltage	V	3 (Typ.)	3 (Typ.)
Supply current	mA	—	0.6
Measurement range	m/s <sup>2</sup> (G)	±29.4 (3)	±29.4 (3)
Sensitivity @9.8 m/s <sup>2</sup> (1G)	mV	2±25%	333±3%
Offset voltage	mV	±4.0	±10
Sensitivity drift*	%	±10	±5
Offset drift*	%	±40	±5
Non-linearity	%	±1	±1
Cross-axis sensitivity	%	6	6
Frequency response	Hz	~ 200	~ 200
Shock durability	m/s <sup>2</sup> (G)	49,000 (5,000)	49,000 (5,000)

\* Temperature range is -25 to +75°C.

Electrical performance

## GSO Single Crystal for PET

Hitachi Chemical Co., Ltd. has developed a large GSO (Ce-doped  $\text{Gd}_2\text{SiO}_5$ ) single crystal with a diameter of 105 mm.

GSO is a good scintillation material for high-speed  $\gamma$ -ray detection and is highly sensitive. It is used as a  $\gamma$ -ray detector in Philips' high-performance PET (positron emission tomography) device "ALLEGRO\*." Its superior energy resolution enables accurate PET, and ALLEGRO can detect cancer deep in the body.

\* See "Trademarks" on page 90.



Large GSO single crystal with size of  $\phi 105 \times 290$  (mm) (above), GSO-PET "ALLEGRO" (below right) and GSO scintillators (below left)

## Interlayer Dielectric Material: HSG-200X Series with Low Dielectric Constant for 65-nm-node Technology and Beyond ULSIs

Interlayer dielectric materials with lower dielectric constant ( $k$ ) than  $\text{SiO}_2$  (silicon dioxide,  $k = 4.0$ ) have been widely evaluated as representing a new technology in higher performance logic devices such as microprocessing units.  $\text{SiO}_2$  is mainly used in interlayer dielectrics in up to 130-nm-node technology; however, 65-nm-node technology and beyond ULSIs require interlayer dielectrics with lower dielectric constant ( $k < 2.5$ ) to decrease line-to-line capacitance. Such materials, especially porous ones, have not been introduced thus far. A serious problem is their poor mechanical strength, which results in damage such as delamination and cohesive fracture during CMP (chemical mechanical polishing) and packaging processes.

The HSG-200X series is siloxane-based spin-on low- $k$  ( $k = 2.3$ ) material, which will achieve a higher mechanical strength (Young's modulus of 12 GPa) and better adhesion to other layers by optimized siloxane skeleton composition and new pore technology. It can achieve fabrication of the HSG-200X through wafer and packaging processes. The HSG-200X series is a candidate for the interlayer dielectrics of 65-nm-node technology and beyond ULSIs.

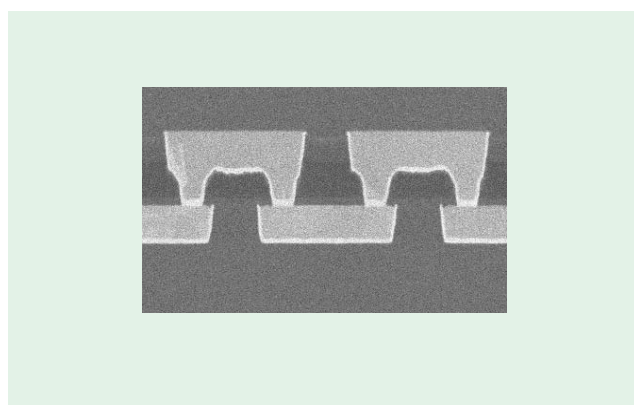

Damascene Cu wiring (cross-sectional) by HSG-200X series interlayer dielectric material  
S. Sone, et al.: VLSI, 125, Selete (2003).