

The background features a light pink grid pattern. Overlaid on this are several thick, semi-transparent, colorful bands that swirl and curve across the page. The colors include shades of orange, red, yellow, green, blue, and purple. A semi-transparent red rectangular box is positioned in the center-right area, containing the main title and a list of services.

# Information Systems

Solution Services  
Software  
Hardware  
Network Systems  
Image and Information Equipment  
e-Learning  
Communication Devices



## Momentum for Joint-outsourcing Electric Application System: Okayama Prefecture's Case

Today, local governments have begun to build e-local governments to improve services for residents and the efficiency of administrative procedures. Challenges such as securing financial resources, providing services 24 hours and 7 days a week, and securing human resources with IT specialization need to be overcome to create the e-local government. Joint outsourcing where multiple local governments use one information system is an effective method of resolving these challenges.

Recently, local governments were granted the legal right to take care of procedures on line, such as filling out applications or notifications between residents and the governments.

Hitachi has constructed an electric application reception system with functions necessary for the joint outsourcing and has delivered the first-ever system to the Okayama prefectural government in Japan. This system is a portal where local residents and businesses use the e-prefectural government and its core.

The government has set up the Okayama e-Prefectural Government Promotion Council to accomplish what is needed for the e-

prefectural government, and for establishing and operating the information systems. In addition, Okayama has developed a specific action plan: The Okayama Prefecture Digitized Administration Promotion Plan (for Comfortable e-Prefectural Government in Okayama). The intention is to switch to an advanced administrative system across the country.

Municipalities within Okayama Prefecture share the electronic application system installed in the data center in Okayama Prefecture through the Okayama Information Highway, which is a fiber-optic network. Therefore, municipalities can provide services for residents without their own equipment and functions. Also residents can conduct administrative procedures seamlessly with the system.

From now on, the number of online administrative procedures will be extended depending on the improvements in the individual authentication platform and the electronic settlement of this system.

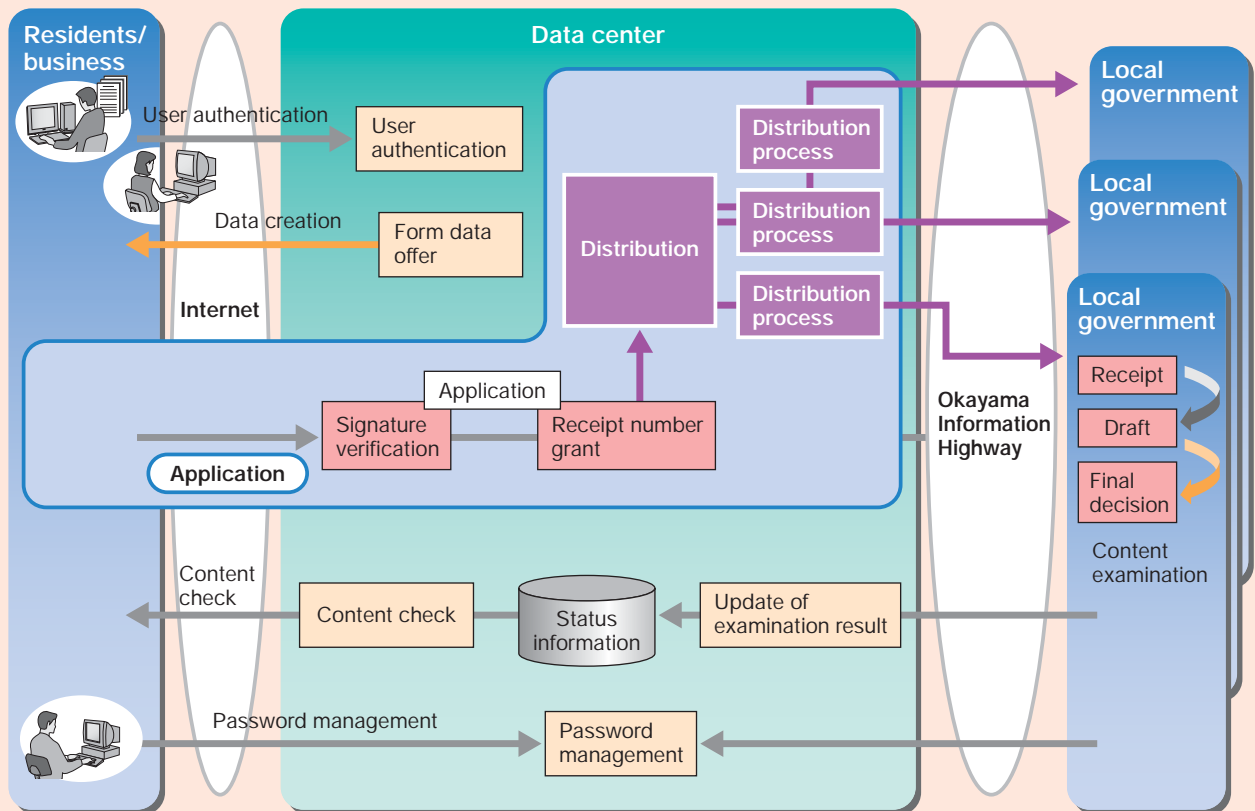

Block diagram of joint-use type electronic application receptionist system

# Business Start-up of Financial Solution in China

To expand our financial solution business activities to the Chinese market, Hitachi is now promoting the development and sales of products for financial customers with major SI partners there (NEUSOFT, TALENT, GUOGUANG). In collaboration with those SI partners, Hitachi provides customers with application and system know-how, acquired through its long-term experience in the Japanese financial market. In addition, the collaboration contains software consignment development for Japanese financial customers. In the past, the information system of the Chinese financial market was mainly core accounting system. New needs such as busi-

ness management system and financial CRM system have quickly emerged because of foreseeable increase in competition due to China's entrance into the WTO. To meet these emerging needs, Hitachi will provide financial solutions and consultations such as the Enterprise Management System (financial ERP), Customer Management System (marketing), Enterprise Audit System (profit/risk integration management), in addition to the hardware business consisting of ATMs (through local subsidiaries and partners), and RAID (through Hitachi Data Systems). This is an area in which Hitachi has established a business presence in China.

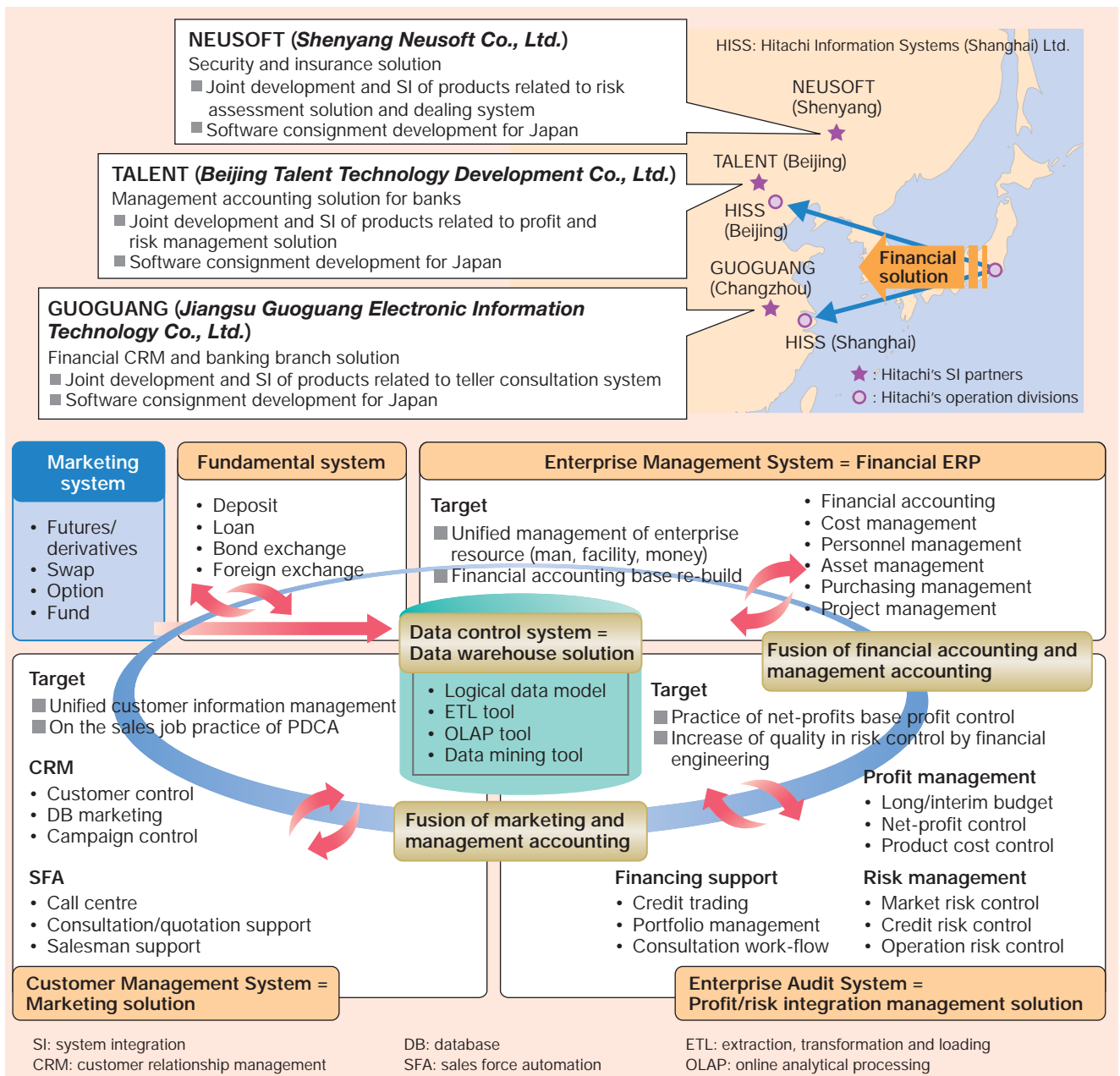

Important SI partners and location (above) and Hitachi's financial solution and environment (below)



## PG/Oneway: Unidirectional Gateway Device

As anti-cyber terrorist measures related to key social infrastructure such as electric power and transportation facilities, security measures in data control systems have become increasingly important. Hitachi, Ltd. has turned its PointGuard plant firewall into a series of products, and expanded its application to systems. One of the new products is PG/Oneway, having the principal feature of allowing data to travel in only one direction. Different from ordinary firewalls that control communications theoretically and via software, PG/Oneway is a firewall device that shuts out communications at selected layers in a network hierarchy using hardware.

Specifically, at the hardware level a plant's communications network cuts off one direction of communications from plant's external network to its internal system, thus preventing unauthorized access and protecting the plant. In contrast, PG/Oneway has a function for transmitting data from inside the plant to the outside, thus allowing supervisory screens from the

operation table to pass through PG/Oneway and be displayed on remote terminals connected to an external network. Remote supervision of a plant's operations can thus be conducted easily and securely.

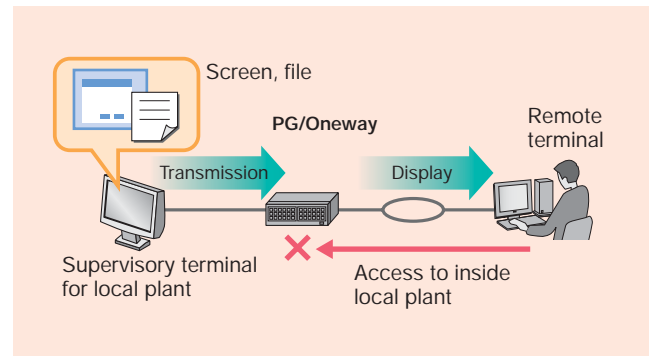

Secure remote supervision using PG/Oneway

## Digital Pen Solution for Information Tracing Application

Since July 2003, Hitachi has provided the Digital Pen Solution that enhances work efficiency with the conventional way of using pen and paper. When handwritten data stored in a pen is sent to the system, it recognizes the form the data was written in so that the data is automatically transferred to an appropriate application.

One of the virtues of this solution is that it facilitates recording, storing, and tracing of information. Therefore, logistics traceability has great potential.

In a traditional delivery service, a deliverer gets a signature or seal from a customer on a duplicate delivery slip. Several problems have been pointed out with this method: for instance, the time and effort needed to search for information and the cost of storing paper documents. With the Digital Pen Solution, the slip is stored with the customer, and the deliverer sends digital data back at his office. Then, the system recognizes the delivery has been completed, and it is recorded in the database.

This solution achieves the following benefits.

- (1) Creates a database of delivery information and enables quick searching
- (2) Ensures secure reliability of data as it records the signed image and the exact timing of the delivery
- (3) Reduces the cost of storing forms

Hitachi will apply this solution to other areas of traceability such as production management and positioning information.

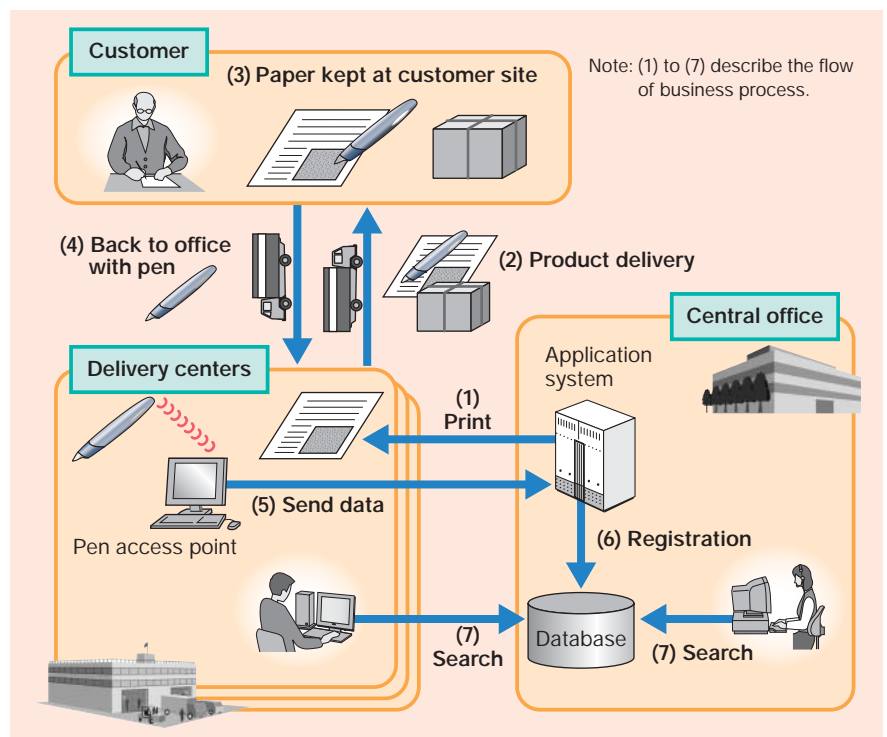

Note: (1) to (7) describe the flow of business process.

Delivery service with Digital Pen Solution

# Hitachi Performance and Learning Upgrade Support System

HIPLUS (Hitachi performance and learning upgrade support system) is an e-learning platform of Hitachi Electronics Services, Co., Ltd. It manages all types of learning such as WBT (web-based training) and classroom training. HIPLUS is composed of three systems that consistently achieve all processes from course development planning, implementation / execution, evaluation, to skill and competency management within all learning activities. The three systems are WBT, Blended Learning Management system and Human Resources Development and Management system.

## (1) WBT system

Learners study accessing e-learning content through ordinary web browsers.

The WBT system of HIPLUS has many functions for assuring highly effective learning. The learning portal page is prepared for each learner. The learner can find all activities that they have to do in their page. Many communication functions can be used such as mentoring, the virtual classroom and bulletin boards. These functions prevent failures in learning.

Course developers can easily create the ISO standard (Sharable Content Object Reference Model) content.

## (2) Blended Learning Management system

Blended learning is a combination of many learning types such as classroom learning and WBT. Using blended learning, users can increase the effectiveness of learning and reduce the classroom hours.

For example, users can use blended learning to the level all

learners are comfortable with before entering the classroom. Learners study prerequisite knowledge through e-learning. In this way, they will all be at the same level when they participate in the class. Thus, the period of learning in the classroom is shortened.

All resources such as e-learning courses, classrooms, and correspondence courses are intensively controlled by the Blended Learning Management system.

As a result, users can unify all management of resources that are included in all learning processes such as course development planning, developing courses, course guides, management of applicants, opening courses / executions, classrooms, and teaching materials. This function assures high efficiency in learning management jobs.

## (3) Human Resources Development and Management system

The Human Resources Development and Management system clarifies necessary skill and competency for accomplishing each business. It also manages the learning history, self-evaluation, and manager's evaluation. It manages all skills and competencies of the organization using this data. The differences between necessary skills for the business and skills which people have are clearly displayed as a skill gap. So, learners and managers can determine the learning plan needed to bridge it.

As a result, each learner acquires his/her skills and competencies through the best study pass.

Using this strategic learning management tool of HIPLUS, high business performance can be achieved.

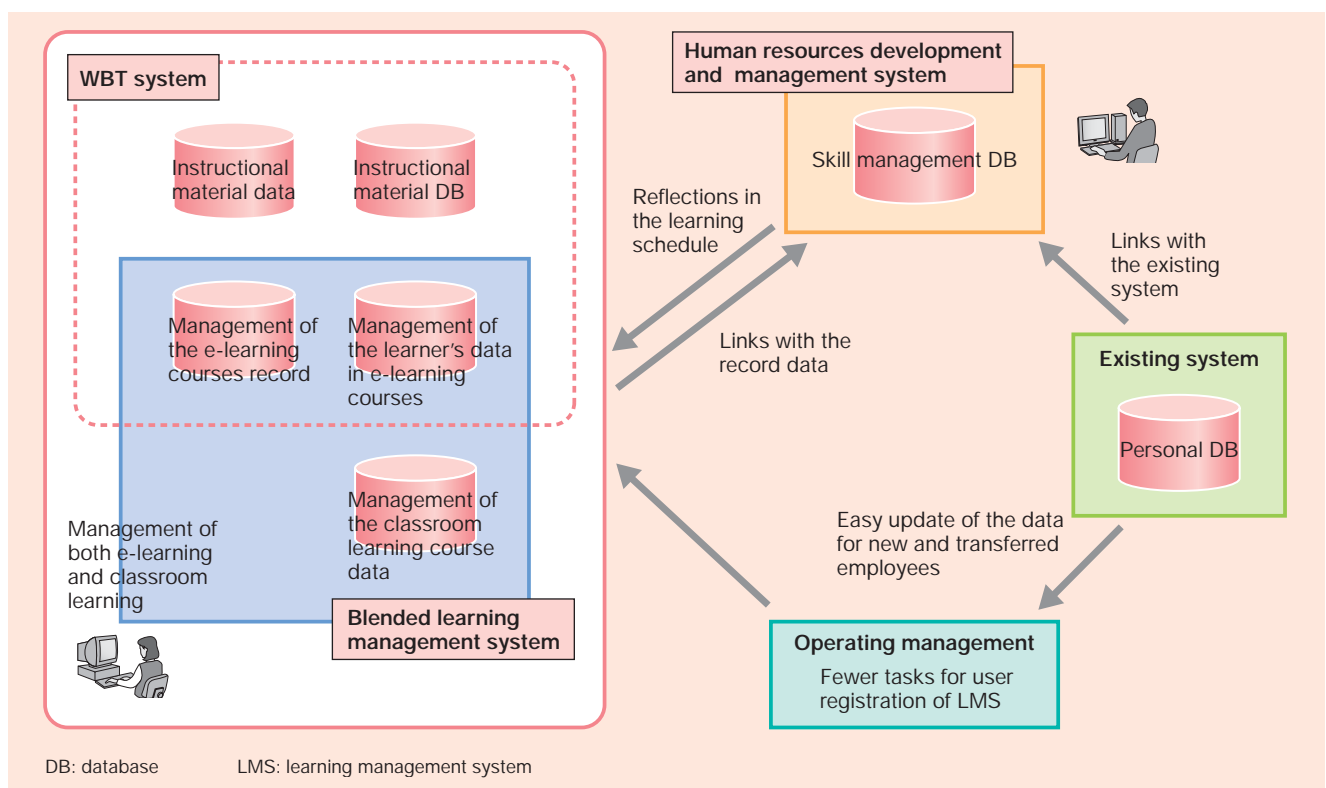

Hitachi performance and learning upgrade support system



# Job Management Partner 1 Version 7i: Moving Towards Achievement of Policy-based Autonomous Operations Management

Information systems are, in effect, the lifeline of a company's business activities, and must be robust and able to run continuously without stopping 24 hours and 7 days a week. To do this, an information system's operation and performance status need to be clearly understood.

Hitachi is working on achieving information systems that can, by setting policies based on customer businesses and operations, provide higher value service comfortably and easily.

The latest edition of Hitachi's job management partner 1 provides the first step in a series of enhancements for achieving policy-based autonomous operations management.

Its enhancements allow an administrator to understand and analyze performance information data from a wide variety of angles, including servers and other devices, applications, and Internet services, and it provides problem-solving assistance during system failures, while also providing functions that help the administrator to predict problems before they occur. It also allows the administrator to output reports of collected performance information. Using these new abilities, the administrator can achieve proactive management that prevents problems beforehand and also achieves autonomous operations.

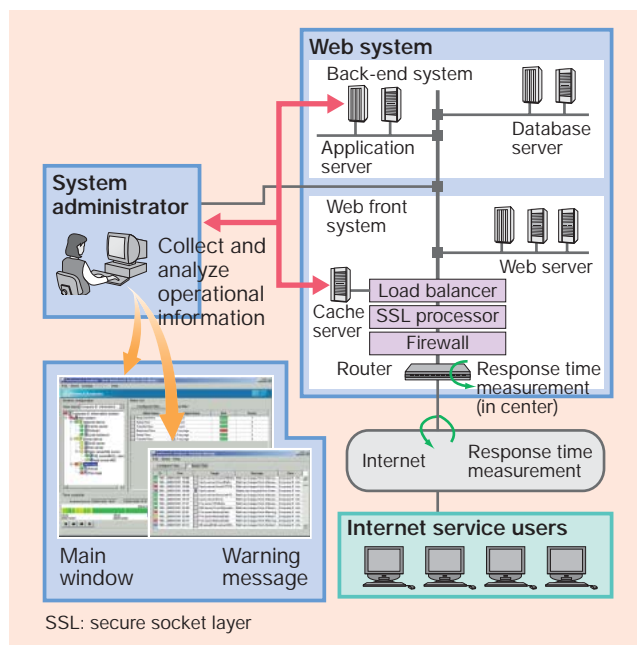

Example of Internet service performance analysis

# Hitachi Relational Database Management System Solutions for Disaster Recovery to Support Business Continuity

Because information provides a new lifeline service, database systems are required to be more reliable and available to keep our business stable.

The Hitachi RDBMS (Hitachi Relational Database Management System) securely supports the information lifeline with innovative functions such as non-stop reliability, security, and ease of operation, based on its reliable and high-performance technology. In addition to non-stop reliability in the event of a local failure, Hitachi RDBMS also provides disaster recovery solutions if an earthquake, flood, or regional power failure occurs. Even if a disaster happens, the user can quickly reopen his/her business by switching over to the remote replication site.

Figure shows Hitachi's real-time SAN replication solution for disasters. User data in the local site is replicated to the remote site using the Hitachi TrueCopy functionality\* of the Thunder/Lightning disk array subsystems.

A database system updates its data frequently, and it takes a long time to transfer the data block to a remote site synchronously. Hitachi RDBMS's novel checkpoint technology makes it possible to transfer data blocks asynchronously and system log blocks synchronously. Hitachi RDBMS's "hybrid remote copy technology" solves the issue of online performance decline for long-distance disaster recovery solutions. Because log blocks are transferred synchronously, no transaction will be lost. Using Hitachi RDBMS, a user can build mission critical IT systems that ensure continuity in business.

\* The Hitachi TrueCopy (server-free remote copy) functionality allows data to be copied between Thunder/Lightning storage subsystems without going through the host computer.

Note: This R&D was partly supported by the e-Society Leading Project (Development of foundation software: Storage Fusion, Tokyo Univ. and Hitachi, Ltd.) of the Ministry of Education, Culture, Sports, Science and Technology.

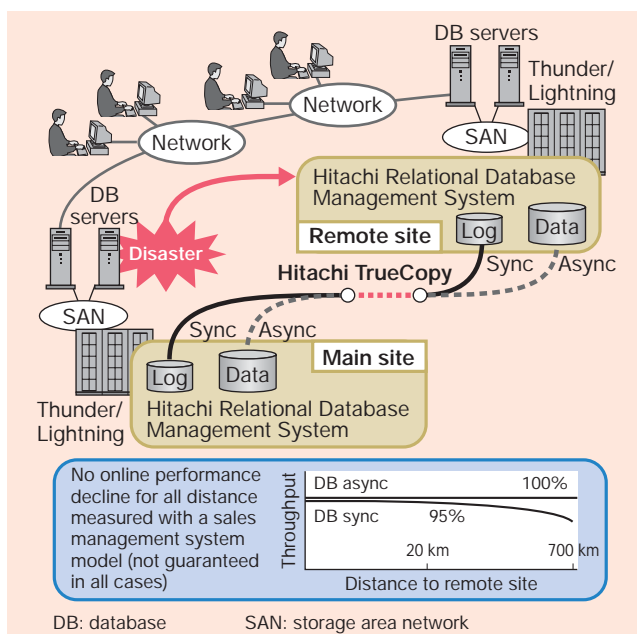

Real-time SAN replication

## New Super Technical Server

To meet the growing demand for large-scale scientific and technical calculations, Hitachi has developed the new super technical server, a high performance parallel computer with world class performance.

The server offers massive amounts of computational power and outstanding system balance by combining high performance processors and a high-speed inter-node network.

The Model H1, which is the first model of the new super technical server series, can be configured from 64 processors up to a maximum of 4,096 processors according to user requirements. With the maximum configuration, the processing capability is a world class 27.8 TFLOPS (tera floating-point operations per second). Compared with its predecessor, the Model H1 shows a 4-fold performance improvement.

Besides fluid analysis, crash analysis, weather forecasting, etc., the Model H1 also delivers high performance in new application fields, such as nanotechnology, biotechnology, and environmental simulations. It can also be applied to grid computing for scientific and technical calculations.

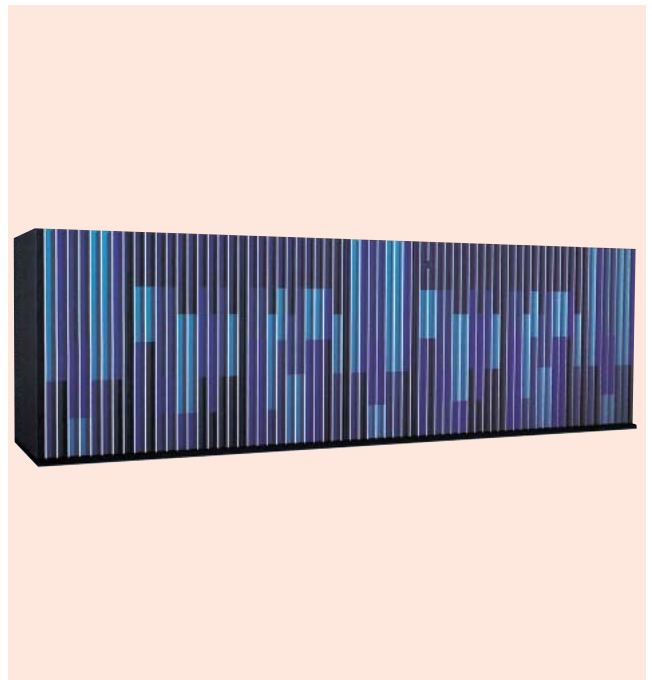

New super technical server Model H1 (512-processor configuration)

## Enterprise UNIX Server Series

The improved enterprise server 690 has been added to the lineup of Hitachi's enterprise UNIX\* server series, which uses the AIX OS (operating system) and was designed for the open and mission-



Enterprise server 690 (Power4+ 1.9 GHz)

critical marketplace.

The enterprise server 690, which can support up to a maximum of 32 processors, is a high-end server of enterprise UNIX servers. The new 690 adopts the newest POWER4+\* processor with a clock rate of 1.9 GHz and supports a memory capacity of 1 TB (tera byte). Thereby, compared with the 690, which uses a 1.7-GHz POWER4+ processor, the new 690 provides a performance 30% higher.

In addition, Hitachi is concentrating on enhancing the reliability and availability of the system with enterprise UNIX servers.

The software developed for enterprise UNIX servers enables a high-speed switchover for hot-standby systems running Hitachi's database management system and high-availability software. This shortens switchover latency from several 10 seconds to nearly 10 seconds. This can minimize the damage caused by a system obstacle.

The Hitachi enterprise UNIX server series can serve a user's needs broadly from an Internet server to a large-scale database system or on-line transaction processing system.

\* See "Trademarks" on page 90.



## Enterprise Server Series Supporting Informational Lifeline

The enterprise server series for Hitachi's proprietary operating system has the high reliability and high availability needed for a mission-critical system. This series inherits Hitachi's proprietary program property in which users are already accustomed. And the cooperation of an open system and mission-critical system makes new business possible. This series supports a mission-critical system in the informational lifeline age.

(1) Enterprise server for powerful support of mission-critical work

This enterprise server features a 64-bit architecture based on newly developed CMOS (complementary metal-oxide semiconductor) processors. Therefore, this server can expand the scale of on-line operations as well as accelerate the database and batch processing, and it achieves high-speed large-scale data processing. Regarding the server's operating systems, Hitachi's virtual-storage operating system (which provides the main support for mission-critical work) and Linux are implemented. This combination of operating systems enables an "all-in-one" server configuration for supporting web applications.

(2) New-generation enterprise server

The new-generation enterprise server uses the POWER processor as an instruction processor, and supports Hitachi's proprietary operating system using emulation technology developed by Hitachi. Moreover, Hitachi provides a hybrid system in which

the proprietary operating system and the AIX work together using partitioning technology.



New-generation enterprise server (left) and enterprise server for powerful support of mission-critical work (right)

## Development of World's First NAS Blade Directly Attached to Enterprise Disk Array Subsystem

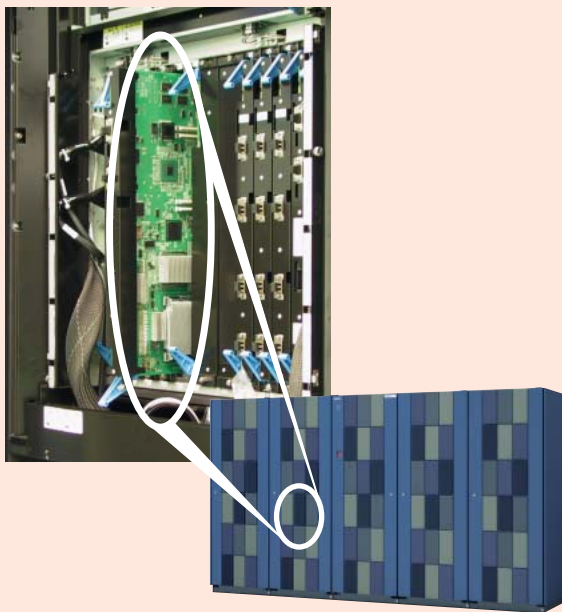

Appearance of enterprise disk array subsystem and world's first NAS blade that can directly connect to subsystem (upper left)

System environments are becoming more complicated as the amount of data in them increases rapidly. The use of adequate storage devices to address various needs has become common, so the need for effective storage consolidation is growing.

To meet these needs, Hitachi developed a NAS (network attached storage) blade for the enterprise disk array subsystem as the world's first product in its class. This NAS blade is directly connected to the inside of a disk array that uses the high performance architecture HiStar, and achieves intermix management of both SAN (storage area network) data and NAS data in the same cabinet. It is not necessary to prepare SAN components such as fibre channel cables or switches or to do complicated connections or settings, insuring simplified installation and configuration changes. This direct connection to the disk array enables data access without using the SAN components and improves reliability and reduces overhead impacting the access time compared with the conventional data access method through the SAN components.

Hitachi has a plan to also develop an iSCSI blade in the near future, and will strengthen the capability of handling Multi-network Environment using the enterprise disk array subsystem based on Hitachi's storage concept.

# Thunder9585V Disk Array Subsystem Realizing World-highest Class Performance in Midrange Class

The needs for effective storage consolidation are also growing in midrange class. To meet these needs, Hitachi developed the "Thunder9585V," designed to be the highest-end model in its lineup of modular disk array subsystems "Thunder9500V Series."

With compact 3U (about 133.4 mm) height enclosures, the Thunder9585V provides maximum 8 ports each for host interface and drive interface, which are double of the existing model Thunder9570V. This realizes world-highest class sequential access performance, which is 1.9 times higher than the existing model. The maximum number of hard disk drives within a subsystem has increased up to 449 and the storage capacity can be expanded up to 60.1 Tbyte, which is double of the existing model. The cache capacity has also increased up to 8 Gbyte, which is double of the existing model.

In addition to the existing functions such as Storage Pooling and Disaster Recovery, newly supported functions such as Volume Snapshot and Heterogeneous Copy with the high-end "Lightning9900V Series," enable Thunder9500V Series to sup-

port various backup systems and to consolidate storages in Multi-network Environment.



Thunder9585V disk array subsystem realizing world-highest class performance in midrange class

# Hitachi Enhanced HiCommand Suite to Satisfy Need for Multi-vendor Storage Service

Hitachi HiCommand Suite for SAM (storage area management) helps address the challenges organizations face from having an ever-increasing storage capacity. IT groups struggle to ensure the availability and performance of their organization's critical data, in part because they have no unified view of their overall storage infrastructure even if they manage to keep staff trained on a wide range of device-specific management tools. By tightly integrating Hitachi HiCommand Device Manager and Tuning Manager with award-winning technology from AppIQ, HiCommand Suite provides application-centric capacity and performance management of an organization's entire storage infrastructure.

By monitoring, visually rendering, and managing the data

infrastructure as a whole (including storage from multiple vendors as well as the switches, host bus adapters, servers, and file systems that serve business applications), the HiCommand Suite delivers quantifiable benefits via higher availability and performance for the critical applications that drive business processes. Built on industry standards, the HiCommand Suite provides a tightly integrated set of application and business modules that enable organizations to manage their entire multi-brand storage infrastructure as a shared utility. By meeting quality of storage service requirements, quantifying that service in reports and business unit charge backs, maximizing storage utilization, and improving operations, the HiCommand Suite helps organizations maximize their storage efficiency and payback.

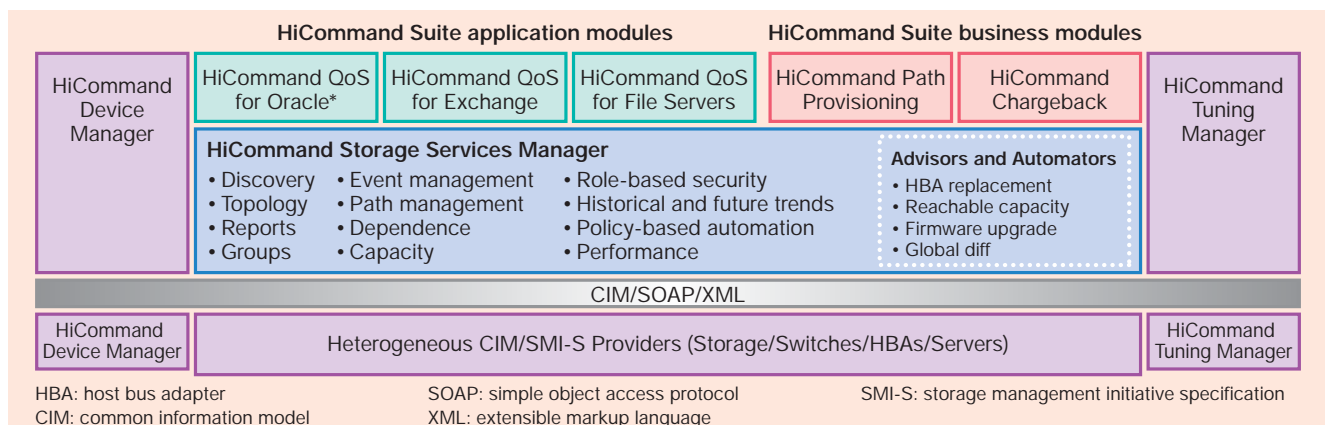

Enhanced HiCommand Suite

\* See "Trademarks" on page 90.



## Distributed Type PI/O Module Makes High-speed Transcription of Process Data Possible by Multi-master Function

Hitachi, Ltd. has developed a distributed type PI/O module that boasts of high dependability and has a multi-master function that makes possible the input and output of transcription from multiple CPUs.

[Main features]

- (1) A link function between CPUs was realized through the multi-master function of R.Link/M, a newly developed high-speed network. It allows the sharing of transcription input/output data from multiple CPUs, and also makes transcription download possible from each CPU to unique output cards.
- (2) Besides R.Link/M circuits, standardized as duplex lines, the PI/O module also realized duplex lines for CPUs, ST, electric power source, and PI/O, hot plug, and various supervisory and diagnostic functions. Its SOE (sequence of event) and 14-bit AI (analog input) functions are also featured.
- (3) By utilizing a TB module for direct connection to the PI/O, the efficiency of both the PI/O packaging and panel wiring has been increased.

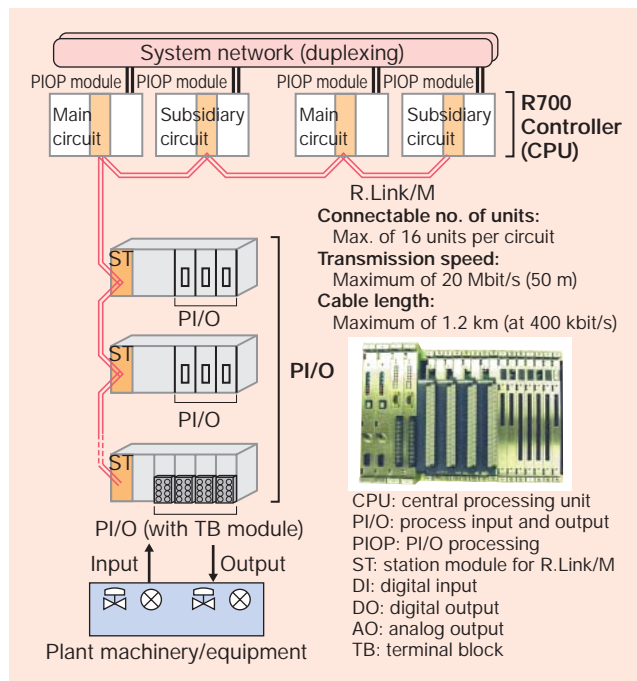

Exterior view of distributed type PI/O module (lower right), and example of system configuration

## IA Server: HA8000 Series

The IA (Internet appliance) server "HA8000 series" has enhanced high performance and reliability.

The HA8000/270 constitutes the core of this series, and achieves high extendibility and high density. It provides the power and scalability for supporting mission critical applications.

[Technical highlights]

- (1) Support for up to four server-processors; it provides scalable system performance.
- (2) 5-U height and up to 1,725-Gbyte capacity using 12 HDDs (146-Gbyte HDD)
- (3) Support for Chipkill ECC memory, which maintains high reliability even in the event of a multi-bit failure for a memory system
- (4) Up to 12-Gbyte PC1600 DDR-SDRAM directly addressable main memory
- (5) 7 hot-plug PCI-X slots and 1 PCI slot
- (6) Redundant and hot-plug fans and power supply

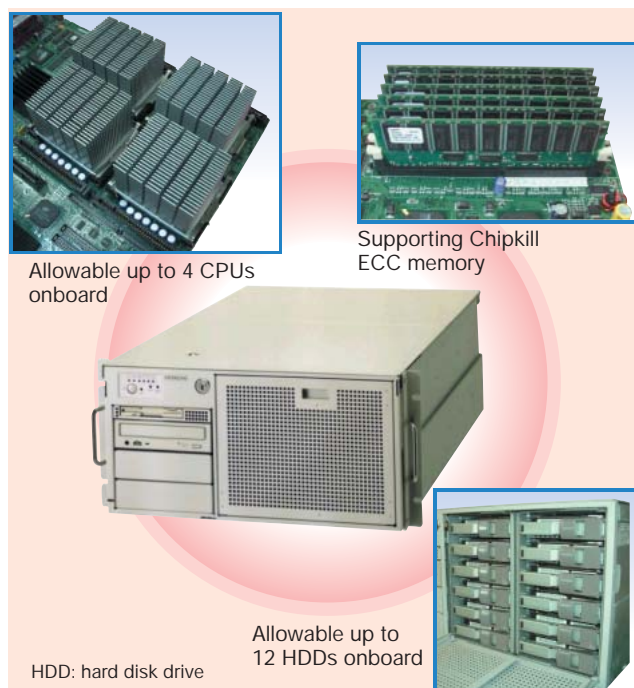

External view of HA800/270 Model (center) and its main internals

## High-performance Reliable Server: HA8500 Series

Hitachi has released HA8500 series high-performance reliable servers, based on the industry standard technology with the Intel Itanium\* Processor Family. The HA8500 series has a powerful product lineup that covers a broad range of 2-way to 64-way. They are useful in both scale-up and scale-out systems with multiple operating systems, HP-UX, 64-bit Windows, and Linux. Customers will be able to choose their best-fit size for servers and a suitable operating system with the HA8500 series. A wide variety of customer solutions, such as mission-critical database systems, high-performance computing, and Internet application servers are well suited for it.

The HA8500/420, a compact 5U height 4-way server, has been introduced as a part of the HA8500 lineup. The model 420 supports up to 32 Gbyte of memory to support solutions with huge data size, such as a warehouse database. In addition, it has 6 internal hard disk drive bays and supports the RAID configuration for the internal disks. It has a Hitachi original designed chipset to provide high performance and high reliability based on the mainframe technology. The chipset brings out the maximum potential of the processor, memory bandwidth, and I/O capacity.

\* See "Trademarks" on page 90.



Compact 4-way server HA8500/420 (left) and high performance 8-way server HA8500/630 (right)

## Industry's Highest\*<sup>1</sup> Density Blade Server with Intel Xeon Processor

Along with the popularization of the ubiquitous environment by such advent as broadband Internet access and mobile devices, the volume of information and demands for more computing power are increasing at a faster rate.

Therefore the blade server, which provides more processing power with higher density, is promising.

Hitachi launched a new blade server system that has higher processing power with the Intel Xeon\*<sup>2</sup> processor. There are many benefits such as hard disk image deployment with the bundled management software and redundant hardware components in this new system just as there are in its predecessor.

[Main features]

- (1) 14 server blades with the Intel Xeon processor can be housed in a 3U (approximately 133 mm) chassis.
- (2) Low power consumption (990 W)
- (3) A VLAN (virtual local area network) compatible switch module meets various demands from carriers, enterprises and others.

\*<sup>1</sup> as of September, 2003

\*<sup>2</sup> See "Trademarks" on page 90.

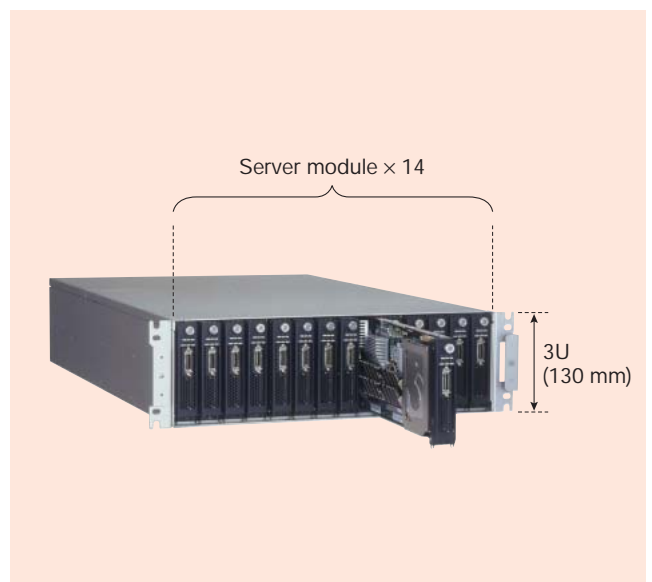

External appearance of industry's highest density blade server



# Deployment of Gigabit Router-based IPv6 Network System in China

China, which is developing rapidly, is right in the middle of an IP (Internet protocol) network expansion. It has an extensive landmass with over 1.3 billion people. A ground swell of interest is growing to build a next-generation network based on an integrated architecture that combines stationary telephones, mobile phones, and the Internet.

Hitachi has a variety of activities in China, which is a promising market for IPv6 (Internet protocol version 6) network equipment. It is promoting the following activities to the Chinese government and telecommunication providers.

(1) In January 2003, Hitachi's IPv4/IPv6 gigabit router 2000 10H/20H passed the IPv6 product certification test that is based on the national standard drafts from the Ministry of Information Industry, a ministry responsible for the telecommunications policy in China. Hitachi's product was the first to pass the test as an IPv6-compatible product. This certification allows a communication provider to connect the gigabit router 2000 to a commercial IPv6 network there.

(2) Hunan Telecom in Hunan started an IPv6 commercial test-bed

project in June 2002. Hitachi participated in this project as a leading vendor, promoting sales activities for IPv6 implementation by demonstrating examples of communication infrastructure and applications.

(3) Hitachi is participating, as a leading vendor, in the Japan-China IPv6 Joint Project that is carried out by both the Japanese and Chinese governments as well as private companies. Hitachi is also involved in the IPv6 Telecom Network Project that is headed by the Ministry of Information Industry of China. Hitachi not only provides equipment for basic communication networks but also is pursuing activities toward starting commercial service in collaboration with the related agencies including the government, telecommunication providers, and academic networks in China.

(4) In October 2002, Hitachi signed a sales consignment contract with the BII Group that is leading the IPv6 field in China. It will increase support in marketing activities that the BII Group provides as a strategic partner and expand the sales of IPv6 products in China.

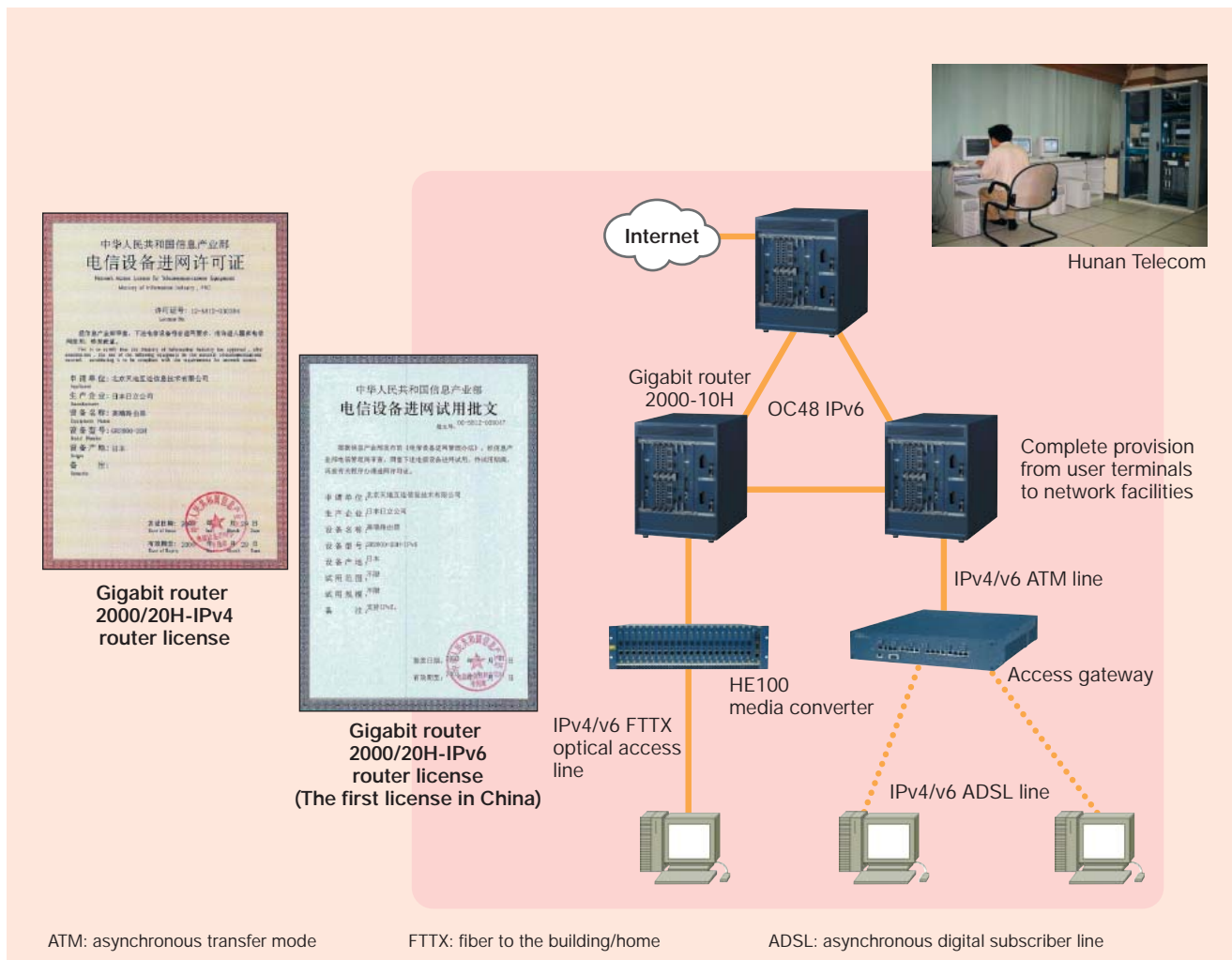

IPv4/IPv6 router licenses and IPv6 commercial test-bed project in Hunan

# New-generation Gigabit Routers and Gigabit Switches

Along with the popularization of the broadband network, the utilization of large-capacity applications such as voices and moving images has expanded year after year. Carriers, enterprises, and public institutions have accelerated their moves to speed up their network performance.

On the one hand, it has increased the amount of mission-critical data such as core operations that are communicated through an IP/Ethernet network, which is basically a best effort network. But only a best effort service is inadequate to apply an IP/Ethernet network as the foundation network for mission-critical quality.

From this background, Hitachi produced gigabit routers for carriers and gigabit switches for enterprises, public institutions, and carriers to actualize a large capacity IP/Ethernet network that guarantees service quality.

[Main features]

## (1) High availability

The gigabit routers and switches have high reliability because they incorporate carefully selected parts and stringent design, production, and inspection standards. For preventing stoppage in network service, these also support standard and unique functions that provide redundant equipment and routes in layer 2 and 3 networks. Customers can also build a reliable network.

## (2) Advanced QoS (quality of service)

The gigabit routers and switches support fine-tuned and high-precision QoS functions, including one that allocates the necessary bandwidth per user and additionally assure the bandwidth per application in the allocated bandwidth on an Ethernet network. When various applications are concurrently communicated in one network, customers can surely communicate mission-critical data in preference to other general data.

## (3) High performance

The gigabit routers and switches support a 10-gigabit Ethernet interface. Additionally, these are equipped with ASICs (application specific integrated circuits) for packet processing and can adequately accommodate increased traffic.

## (4) Compact design

The gigabit routers and switches can save setting space because of the high port density of 1-gigabit/10-gigabit Ethernet interfaces and two types of efficient chassis design that adapt to a user's setting environment.

## (5) IPv6 (Internet protocol version 6)

The gigabit routers and switches provide high-performance IPv6 routing by hardware-based processing as well as IPv4 (Internet protocol version 4) routing. In addition, these are equipped with technologies needed for shifting to IPv6, such as IPv4/IPv6 dual-stack and tunneling, and customers can migrate from IPv4 to IPv6 seamlessly.

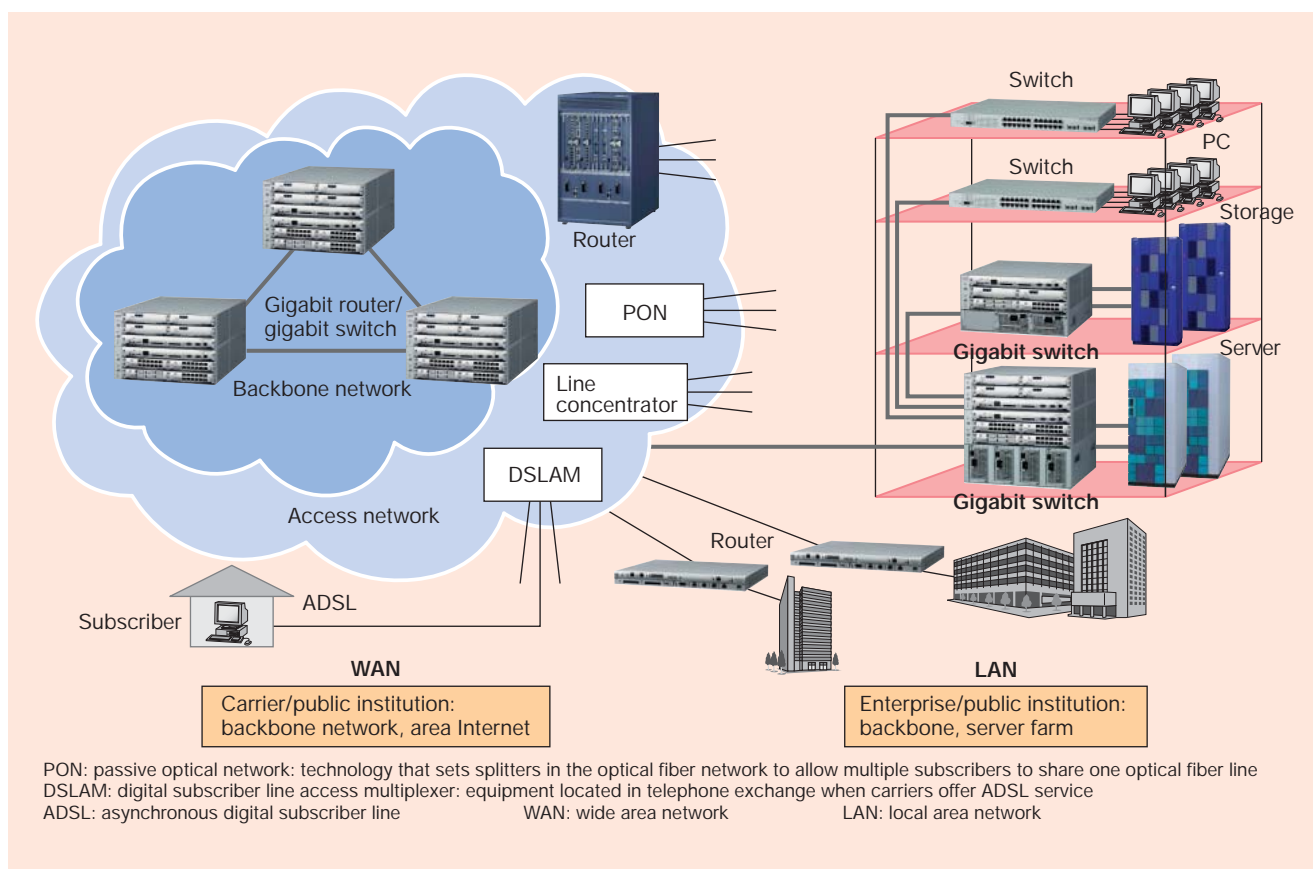

Example application of gigabit routers and gigabit switches



# Software Platform for IPv6 Network Service

This software platform is the basis for a network service to implement services on the Internet economically and efficiently. Positioned between the application and the network platform, it allows network functions to be shared among service applications.

This product's main components are session management, which controls the sessions for direct information transfer between

users, and presence management, which manages the presence information such as user states and preferences. This software enables a variety of services such as multimedia conferences, presence information delivery, and it allows for inexpensive and prompt chatting.

The software will be upgraded to provide security, authentication, mobility, accounting information management, etc.

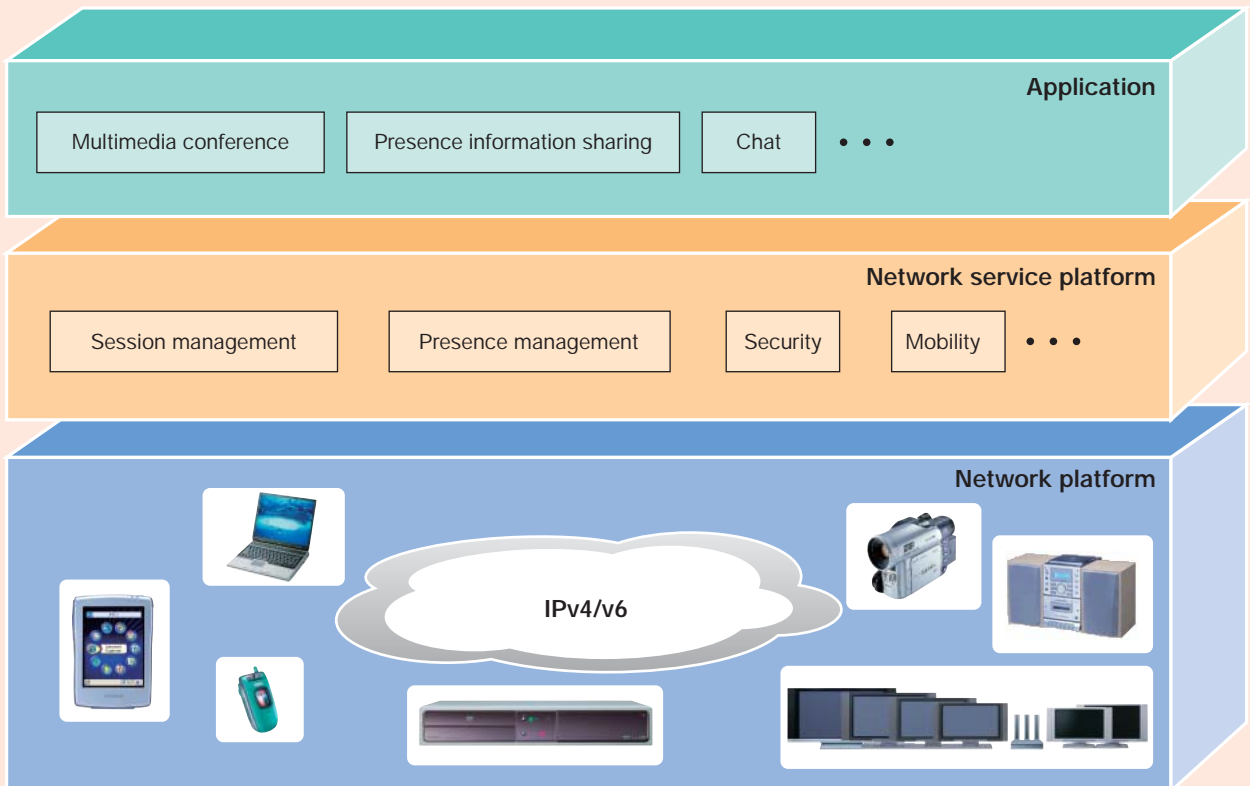

IPv4/v6 : Internet protocol version 4/version 6

Software platform for IPv6 network service

## New 1-U High, High-performance, IPv4/IPv6-compatible Broadband Access Gateway

In a compact body, it offers a transmission performance of 2 Gbit/s, and a maximum connection management function of 4,000 sessions. Moreover, it features the newest IPv6 (Internet protocol version 6), a VR (virtual router), and a VLAN (virtual local area network) function. A DHCPv6-PD (dynamic host configuration protocol version 6—prefix delegation) function

that enables an IPv6 automatic address setup is included, as well as a highly efficient, space-saving, broadband access environment. In addition, a multicasting function that facilitates broadcast services using Internet circuitry is due to be added sometime in May 2004.

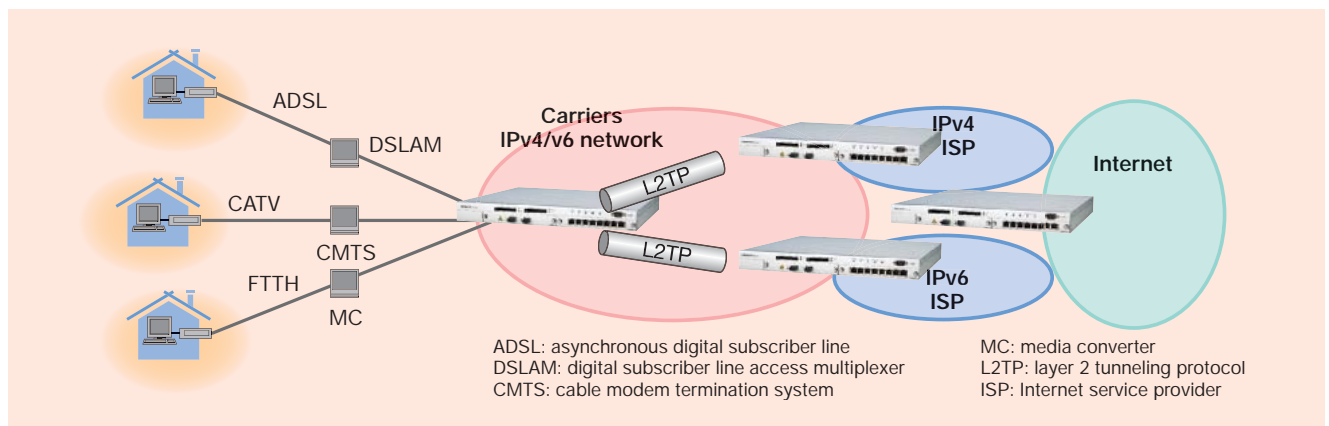

Configuration of broadband access network application of broadband access server and address translator. The broadband access server accommodates a variety of broadband-access lines, such as ADSL, CATV and FTTH. The address translator can bidirectionally interconnect with an IPv4 network and an IPv6 network.

## Gigabit Ethernet PON System

Broadband networks have been expanding widely because of escalating requirements for higher capacity traffic, and they are used in many areas exemplified by the streaming services of video and the wide area LAN services applied to intra-networks connecting distanced branches of the enterprise.

To achieve an economic broadband infrastructure with higher capacity, expectations are such that an access line's speed needs to be made higher than that of the current 100-Mbit/s system.

Hitachi is focusing on the broadband access system and is developing a gigabit Ethernet PON (passive optical network) system complied with IEEE 802.3ah that will be finally approved in 2004.

[Main features]

- (1) Complied with the international standard IEEE 802.3ah.
- (2) Deployment of the DBA (dynamic bandwidth assignment) technique: The DBA technique is based on the statistical multiplexing method and assures a minimum user bandwidth and effectively utilizes unused bandwidth dynamically.
- (3) The PON interface at the OLT (optical line terminal) equipped at the central office can accommodate 64 users at maximum and enables reducing investment cost.

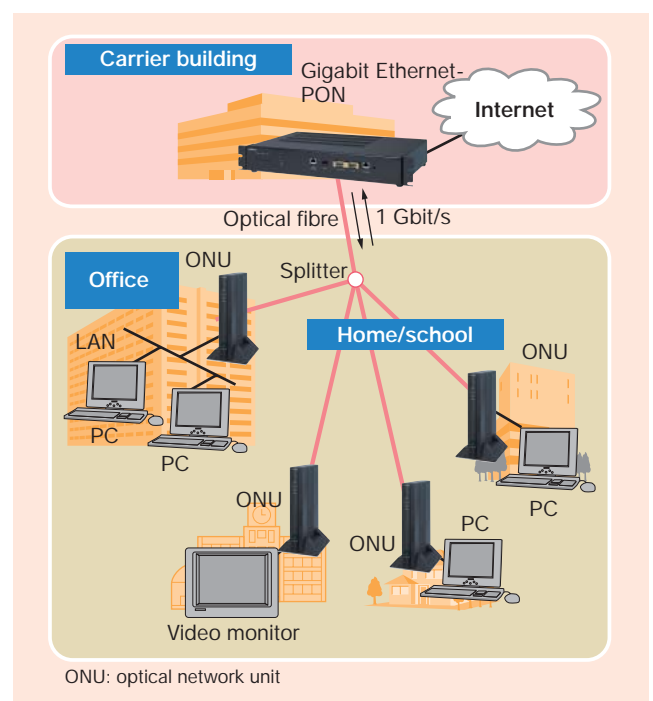

Gigabit Ethernet PON system



## Adaptive Array Antenna Type PHS Cell Station

The personal handyphone system, or PHS, originated in Japan, has been deployed in China since 2000. The number of the PHS subscribers in China is reported to be 38 million as of the end of the year 2003. One of the strongest requirements of the China PHS market is to supply effectual cell stations in a high traffic density area.

To respond to this requirement, Hitachi developed an AAA (adaptive array antenna) PHS cell station. Telephone operators can expand their service area with this AAA cell station, which controls radio wave intensity toward PHS subscriber terminals with adaptive directivity function. Consequently, they can improve the frequency use effect and upgrade the traffic capacity. This adaptive directivity function is achieved by high speed DSP (digital signal processor) modem technologies.

Moreover, this AAA cell station has a group control function, which enables telephone operators to double the traffic capacity without establishing another cell station point if they add on another AAA cell station based on the market change.

Functionally, an SMS (short message system) has been added. With SMS, PHS users can make phone calls and send messages to other PHS users.

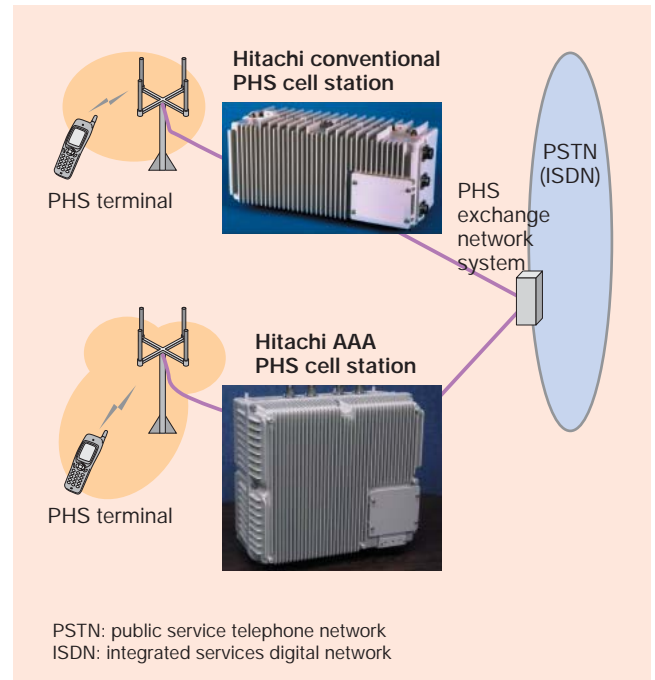

System architecture of PHS cell station

## Next-generation DWDM Node for Metropolitan Optical Networks

The AMN7500 is a next-generation DWDM (dense wavelength division multiplexing) node, and is applicable to metropolitan and access-area large-capacity optical networks. Using the AMN7500 nodes, any network topologies, such as a point-to-point WDM, ring/linear OADM (optical add/drop multiplexing), and a mesh OXC (optical cross connect), are constructed flexibly.

The efficiency of the bandwidth utilization is enhanced by TDM (time division multiplexing) with a GFP (generic frame procedure), VCAT (virtual concatenation), and an LCAS (link capacity adjustment scheme). A variety of user interfaces are GbE, 10 GbE (WAN-PHY/LAN-PHY), OC-3/OC-12/OC-48/OC-192, and fibre channel, with ESCON\* optionally. The total maximum transmission capacity is 320 Gbit/s. An ITU-T G.709 compliant OTN (optical transport network) overhead-processing function is used for the optical path management. FEC (forward error correction) achieves a stable performance over a 640-km (maximum) ring even for 10 Gbit/s interfaces. The optical path is controlled through GMPLS (generalized multi-protocol label switching). Compact shelves are mounted in a 19" rack.

\* See "Trademarks" on page 90.

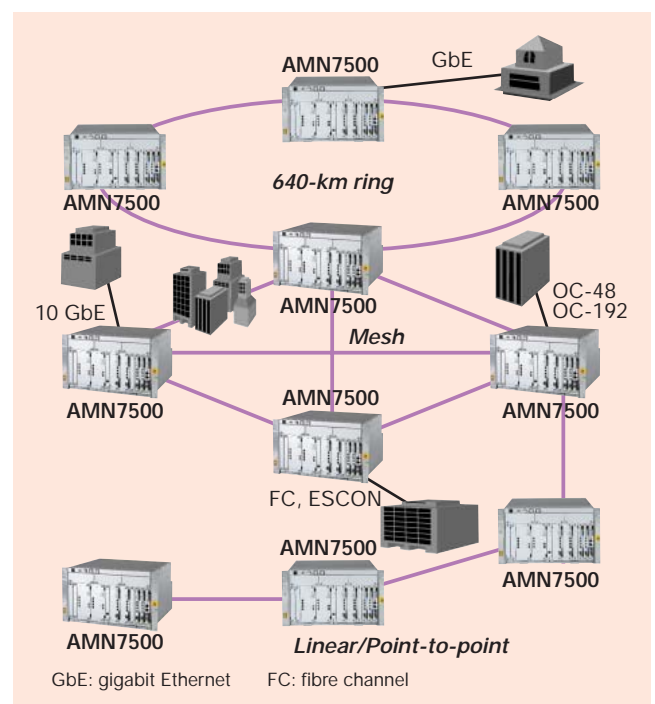

Metro WDM node for next-generation WDM networks

## XFP MSA Compliant Compact-size 10-Gbit/s Optical Transceiver Module

Opnext, Inc. has developed an XFP (10-Gbit/s small form factor pluggable) MSA (multi-source agreement) compliant optical transceiver module that has a compact size of  $W18.4 \times D78 \times H8.5$  (mm), which increases the optical port density of Internet-working equipment.

[Main features]

- (1) Electrical serial interface achieved by built-in waveform shaping function, which enables 10-Gbit/s signal transmission on the glass epoxy board up to 30 cm
- (2) Transmission distances up to 10 km realized by a  $1.3\text{-}\mu\text{m}$  DFB (distributed feedback) laser diode with  $0\text{--}70^\circ\text{C}$  wide operating temperature ranges to achieve low power consumption and compact size
- (3) Coaxial package employed for optical modules, which are mass-productive and able to reduce the cost and module size
- (4) Low power consumption of max 2.0 W using a single supply voltage of 3.3 V.



XFP MSA compliant compact-size 10-Gbit/s optical transceiver modules

## C-band Tunable 10-Gbit/s Optical Transceiver Module

As a DWDM (dense wavelength division multiplexing) transmission system for a metro and long haul broadband network, Opnext, Inc. has developed a 10-Gbit/s optical transceiver module that is capable of tuning every 0.4 nm in the 32 nm C-band range (from 1,530 to 1,562 nm). The system is in response to the growing market needs for tunable optical transceivers that are capable of tuning with a required wavelength spacing of 50 GHz.

This module provides an MSA compliant monitor and alarm function and attains low-jitter and suitable wavelength accuracy for multiple wavelengths. In addition, a newly developed APD (avalanche photo diode) enables it to have higher sensitivity, and the optimized control circuit keeps the power consumption down.

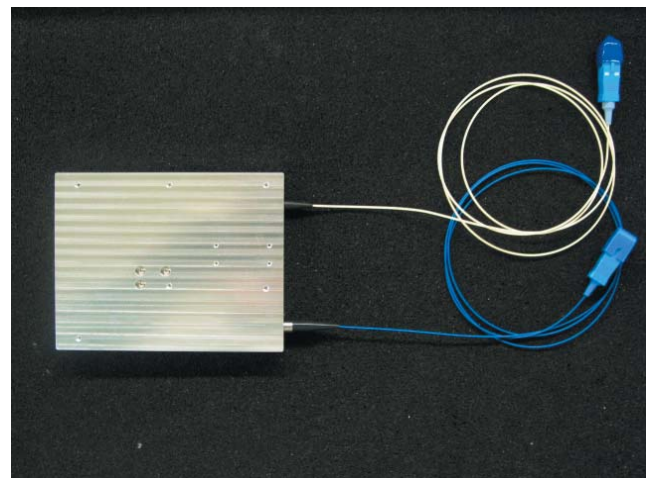

C-band tunable 10-Gbit/s optical transceiver module