

Development of 22-kV Distribution Systems and Switchgear

Shuichi Kikukawa
Kenji Tsuchiya
Satoru Kajiwara
Akira Takahama

OVERVIEW: As the demand for power has continued to grow in cities and other areas of concentrated power consumption, costs are rising due to the lack of sites to locate 6-kV distribution substations and increasingly congested distribution conduits. This has led to a demand for power supply systems and equipment that can boost distribution per line capacity from 6 kV to 22 kV, that can deliver loads close to where the power is consumed, and minimize power losses in distribution which reduces CO₂ emissions and thus helps mitigate global warming. Standing in the way of greater deployment of 22-kV switchgear is that the equipment is larger and more costly than prevailing 6-kV equipment. To address this situation, Hitachi, Ltd. joined forces with The Tokyo Electric Power Co., Inc. to develop more compact and less expensive 22-kV distribution equipment.

INTRODUCTION

ALTHOUGH the availability of 6-kV distribution in urban centers and other areas of concentrated demand for power is quite high, the prospect of boosting 6-kV supply further is fraught with difficulties: it has become extremely difficult to acquire sites for locating new

power distribution substations due to rising land prices and it has become harder to secure distribution routes because power distribution conduits are already congested. On the other hand, most of Japan's power distribution infrastructure in urban areas is underground, so if excavation work is done to lay new

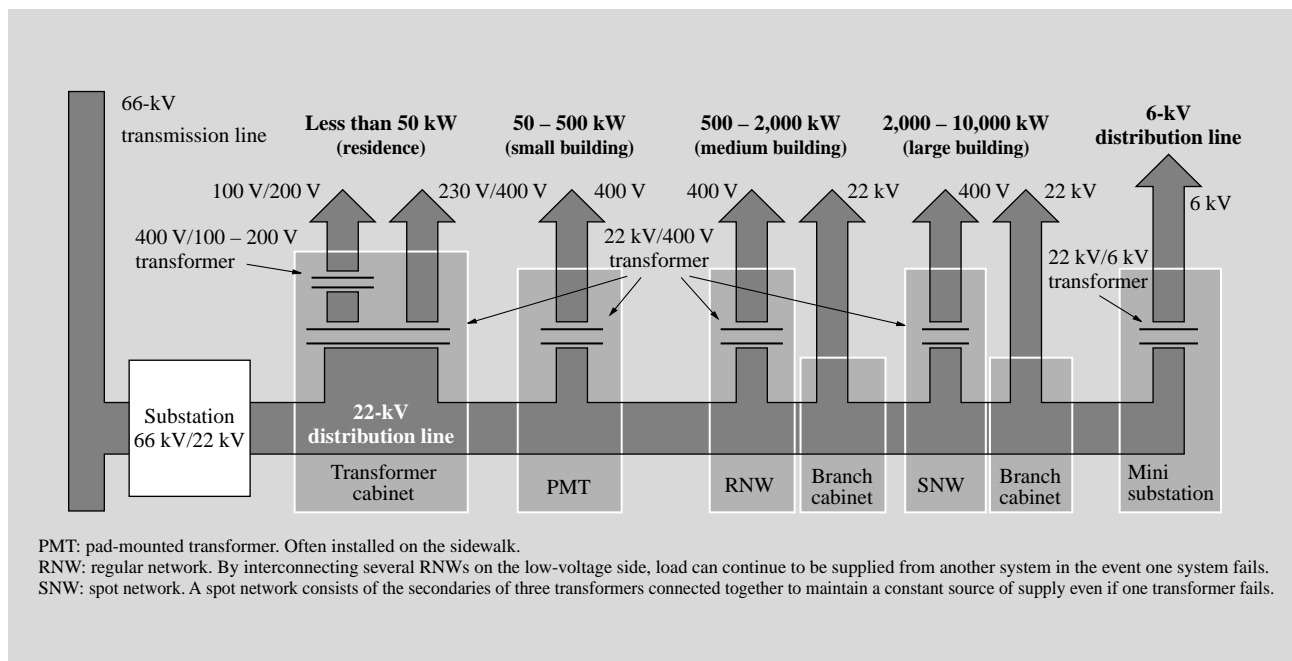

Fig. 1—Overview of 22-kV Distribution System.

Current, which is inversely proportional to voltage, is substantially lower for 22-kV distribution than for conventional 6-kV distribution when the amount of power used is the same. In addition, 22-kV systems give off less CO₂ emissions since energy losses during distribution are proportional to current squared, so 22-kV distribution also helps reduce global warming.

distribution feeders, it makes much more economic sense to deploy 22-kV distribution lines that have about three times the capacity of 6-kV lines. At the same time we must keep in mind the need for existing substations to make effective use of 22-kV equipment and the need to maintain efficient supply through centralized control of 6-kV distribution systems and power distribution.

The primary obstacles standing in the way of further deployment of 22-kV distribution is that this equipment is larger and more costly than comparable 6-kV systems. Challenged to address this situation, Hitachi, Ltd. entered into an alliance with The Tokyo Electric Power Co., Inc. to develop and deploy more compact and less costly 22-kV distribution equipment. In this paper we highlight the main features and applications of the systems that emerged from this joint research initiative; specifically, a 22-kV distribution system, hybrid switchgear, 22-kV/6-kV large-capacity mini substations, 3 N connection transformer (three-phase three-wire single-phase division connection), and 22-kV PMT (pad-mounted transformer) (see Fig. 1).

22-kV DISTRIBUTION SYSTEM

The 22-kV distribution is primarily directed at urban and other densely populated areas, and our efforts are focused on reducing overall costs (by making the equipment more compact and reducing equipment costs), by enhancing the distribution system to ensure improved reliability and better availability. To optimize the distribution efficiency from substations, 22-kV power may be distributed to the point of demand where it is stepped down to 6 kV, or in other cases such as industrial zones and sparsely populated regions, power may be supplied by 6-kV distribution systems. Let us first consider the 22-kV supply side equipment that is currently available¹⁾.

22-kV/Low Voltage Direct Supply

(1) Main and backup line system and loop systems

This is the most common system for receiving 22-kV power. Since it has somewhat smaller transformer capacity than SNWs (spot networks)^{*1}, it is more economical both in terms of space and cost, and is therefore extensively deployed (see Fig. 2).

(2) SNW systems

SNWs are most commonly found in cities and other areas of high demand, and are seeing increasing deployment to exploit their advantages: SNWs maintain a constant sources of supply, consist of

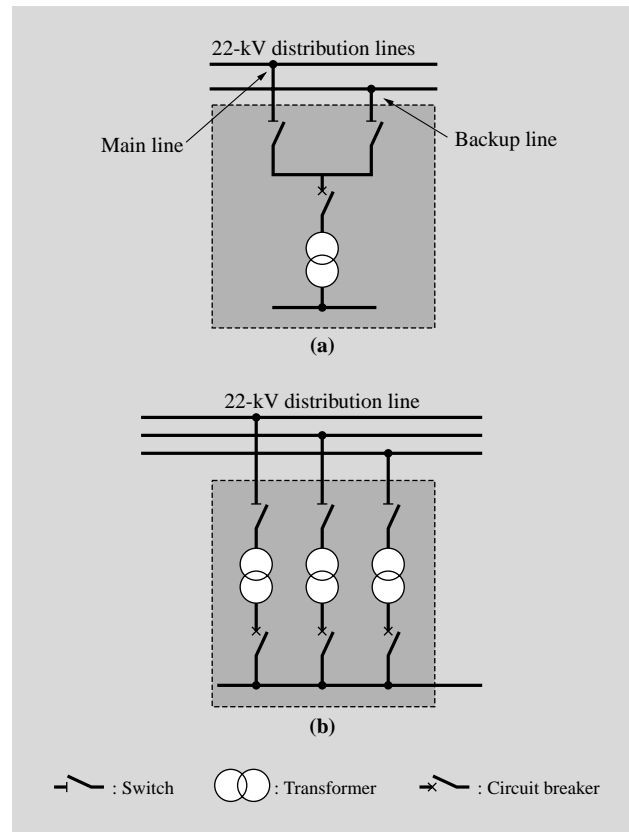

Fig. 2—Schematic Single-line Connection for Distribution Systems.

Connections for main and backup line system (a) and SNW system (b).

secondaries of two or more transformers and therefore continue to supply power even when one line is down for inspection, and have a high degree of maintainability and operability.

SNWs are generally deployed as low-voltage SNWs in which transformer secondaries supply low-voltage power or as high-voltage SNWs in which transformer secondaries supply 6 kV to support efficient distribution within a single building (see Fig. 2).

(3) RNW^{*2} systems

RNW systems maintain a constant source of supply and are generally applied in bustling shopping areas such as Ginza and Shinjuku in Tokyo. However, this system is not being expanded because of the numerous requests from customers for 6-kV power and because the system is insufficient in maintainability, operability,

*1 SNW: spot network. A spot network consists of the secondaries of three transformers connected together to maintain a constant source of supply even if one transformer fails.

*2 RNW: regular network. By interconnecting several RNWs on the low-voltage side, load can continue to be supplied from another system in the event one system fails.

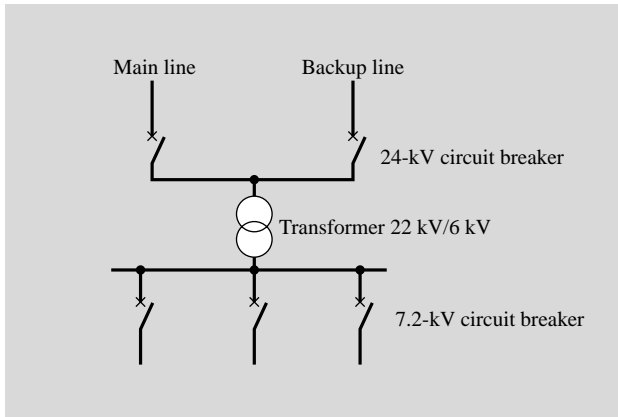

Fig. 3—Schematic Single-line Connection for Mini Substation. The transformer can handle a maximum capacity up to 10 MVA.

and expandability.

22-kV/6-kV Supply

A distribution system has been supplied in which 22 kV is distributed fairly close to customers, then stepped down to 6 kV using a local mini substation. Here we will describe the main/backup line system (mini substation).

While this system has been applied to industrial zones and sparsely populated areas, it would also be effective in densely-populated residential areas. Considering the environment where this system might potentially be deployed, we have focused on increasing the capacity of the system while also making it more compact.

This system is useful not only for supplying 22-kV customers but also for supplying existing 6-kV customers. This not only serves as a transitional system promoting the spread of 22-kV supply, it will also promote increasing application of mini substations (see Fig. 3).

HYBRID SWITCHGEAR ²⁾

Hybrid Switchgear Specifications

The main specifications of the hybrid switchgear are listed in Table 1.

Hybrid Switchgear Configuration

The hybrid switchgear consists of the

- (1) the main circuit section enclosing three three-phase four-position vacuum valves,
- (2) an operation unit that operates vacuum switches,
- (3) and a control section featuring digital protection/metering equipment for protecting main circuits and monitoring current and voltage (see Fig. 4).

The main-circuit section consists of a cable-side

TABLE 1. Main Specifications of Hybrid Switchgear
Notable features include integration of switches and composite insulation.

Item		Specification
Type of switch		Integrated circuit breaker, disconnect switch, and earth switch
Insulation system		Composite insulation: vacuum, SF ₆ gas*1, and epoxy mold
Rated voltage		24 kV
Rated current		200 A, 400 A, 600 A
Rated frequency/phase		50/60 Hz, three-phase
Rated interrupting current		25 kA
Rated short time withstand current		25 kA 1s (main circuit, earthing circuit)
Withstand voltage	Power frequency	50 kV (60 kV)*2
	Lightning impulse	125 kV (145 kV)*2

*1 In some case where less rigorous insulation requirements are called for, the SF₆ gas may be replaced by CO₂ gas, N₂ gas, or dry air.

*2 Figures in parenthesis show performance between disconnectors.

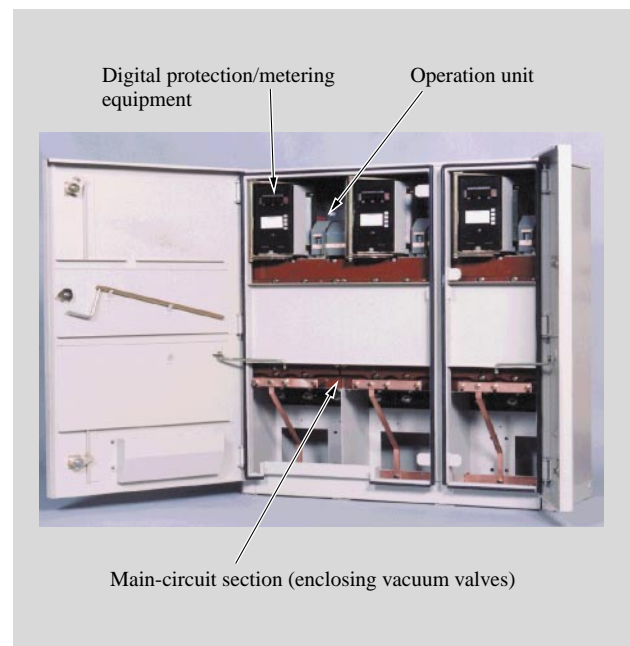

Fig. 4—External View of Hybrid Switchgear. The unit measures 1,100 mm W × 450 mm D × 1,450 mm H (1,500-mm high including the base).

conductor for connecting to the cable head at the bottom of the molded case, a current transformer for metering that is built into the epoxy molded insulated housing, a condenser for voltage detection, and three (for three phases) four-position vacuum switches enclosed in a molded case (see Fig. 5).

Insulation between the vacuum switches is accomplished by a small amount of SF₆ gas in the

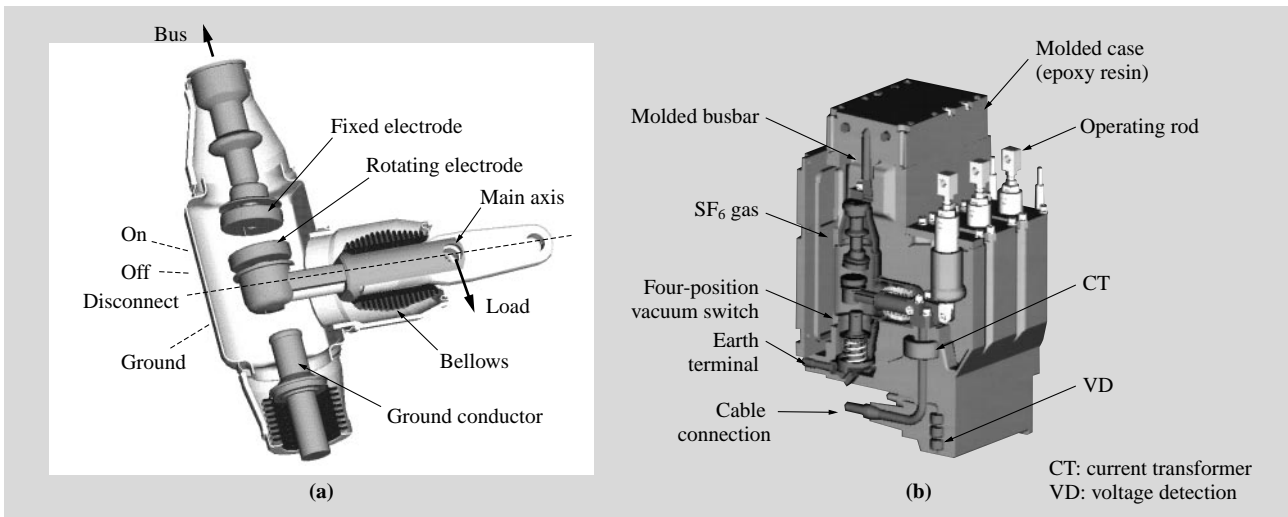

Fig. 5—Internal Structure of Hybrid Switchgear Circuitry. Structure of four-position vacuum valve (a), and cut-away epoxy resin module showing circuitry (b).

molded case and molded insulation plates between the vacuum switches. This composite insulation system provides enhanced reliability.

Considering its potential adverse effect on global warming, the amount of SF₆ gas has been cut to several tenths the level used in earlier versions of our gas-insulated switchgear.

22-KV/6-KV LARGE-CAPACITY MINI SUBSTATION³⁾

New construction of substations has fallen in the sluggish economy even as the demand for energy in urban areas has continued to grow. To cope with these circumstances, we have seen an increasing number of smaller substations and deployment of large-capacity mini substations.

22-kV/6-kV Mini Substation Specifications

Table 2 shows the main parameters of the new mini substations that we recently developed in comparison with the older substations.

New Mini Substation: Key Development Considerations

(1) Smaller floor space

In order to reduce the floor space of the mini substation, hybrid switchgear was used for the 22-kV incoming section, the transformer heat dissipater was implemented more compactly, and regular vacuum circuit breakers were used for the 6 kV distribution section. Even while adding remote monitoring equipment and remote control equipment, we succeeded in reducing the floor space of the new mini

TABLE 2. Comparison of 22-kV/6-kV Mini Substation Specifications
The new mini substations provide greater capacity, enhanced capabilities (including built-in remote monitoring and distribution line coupling capabilities), and are smaller than previous substations.

Item	Old type*	New type
Receiving voltage	22 kV	Same
Distribution voltage	6 kV	Same
Transformer capacity	6 MVA	10 MVA
Load tap changer	No	Yes
Operation room	No	Yes
Remote monitoring equipment	Located separately	Built-in
Remote control equipment	Located separately	Built-in
Floor space	15.4 m ²	9.9 m ²

* Already delivered



Fig. 6—External View of the 22-kV/6-kV Large-capacity Mini Substation. The new mini substation is already being delivered to The Tokyo Electric Power Co., Inc.

substations from 15.4 m³ to 9.9 m³ (see Table 2 and Fig. 6).

(2) Reduced transformer noise

Mini substations are often erected in residential areas, so reducing the noise level (especially at night when people are sleeping) was an important design consideration. We designed an extremely quiet transformer that only emits 45 dB, and reduced the noise level even further by housing the transformer in sound insulated case. A noise level of 45 dB means

that the vibration noise from the transformer can only faintly be heard even when you are right up next to it.

(3) Added operation room

The main equipment on the new mini substation can be operated from a remote location, but can also be operated directly on site in the event of an emergency. Emergencies are often caused by typhoons or other severe weather conditions, so we added a small operation room enabling personnel to operate the distribution equipment from inside the mini substation.

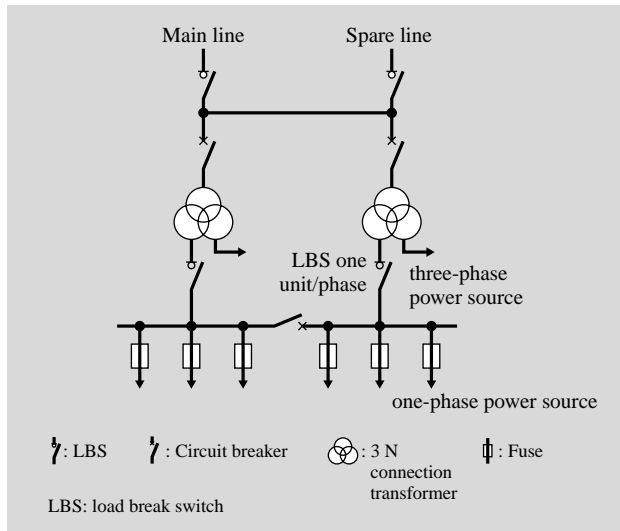

Fig. 7—Schematic Single-line Connection for 3 N Transformer. Single-phase power is mainly used for electric lights and other residential consumer needs, while three-phase power is primarily used for heavier electrical power needs such as operating elevators.

3N TRANSFORMER

Transformers supplying 22-kV/100 V and 200 V for high-rise condominiums and similar buildings have been implemented using separate single-phase transformers for large capacity and for small capacity, and a different capacity V connection system that can supply both single-phase large-capacity loads or three-phase small capacity loads. The problem is that as the transformer is adapted for increased capacity, the increasing transformer secondary current increases conductor cross section and rated capacity of the equipment, and this results in larger size equipment which drives up the cost.

We have sought a solution by changing the transformer connection to a 3 N (three-phase three-wire single-phase division) connection scheme. This divides the current flow on the transformer secondary side equally into three phases, which enable us to replace two single-phase transformers with one three-phase transformer (see Figs. 7 and 8). By implementing

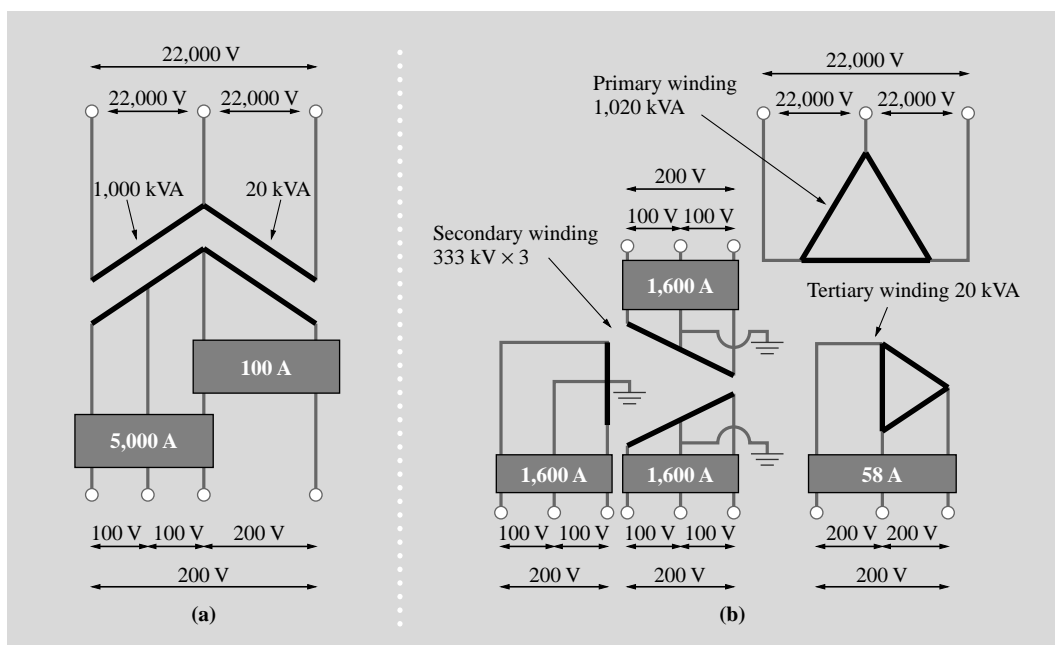

Fig. 8—Comparison of Transformer Cables. The figure compares conventional different capacity voltage connection transformer winding (a) with the 3 N transformer winding (b). At the same capacity, the current on the secondary side of the 3 N transformer is significantly smaller.

the transformer connection of single-phase division, this reduces the current flow is reduced, so the conductor can be smaller. This means that our new transformer occupies a 30% smaller space than the existing different capacity voltage cable method and can also be deployed at substantially lower initial cost.

22-kV PMT

22-kV PMT Development Concept

In order to extend and make 22-kV/400-V loads more pervasively available, the 6-kV distribution PMT that are the norm today must be progressively upgraded to carry 22-kV/400-V loads. Our primary objectives in developing the 22-kV/400-V PMT was to keep it the same size as the 6-kV (125 + 50 kVA) PMT, and to incorporate 24-kV switches and transformer in the same enclosure.

Comparison of New 22-kV PMT and Conventional 6-kV PMT

- (1) Developed for installation on the sidewalk, the external dimensions were designed to be the same as the current 6-kV PMT, which is prescribed by Tokyo Government ordinance.
- (2) We boosted transformer capacitance from the current 125 + 50 kVA to a maximum of 300 kVA.
- (3) Working voltage on the primary side was raised to 22 kV and on the low voltage side was increased from 210-105 V to 400-230 V.
- (4) Primary side switching currently implemented with molded disconnecter and load-break elbow was replaced with a load-break switch.

(5) A current-limiting fuse was installed between the high voltage switch on the primary side and the transformer, the same as the existing 6-kV transformer.

(6) For the transformer insulating oil we adopted silicon oil, which has a higher ignition point than mineral oil.

(7) In existing PMTs both inner (transformer tank) and outer (PMT enclosure) enclosures are connected to the same grounding terminal. However, we have enhanced the security measures (touch and foot voltage) with a double enclosure structure that insulates between the inner and outer enclosures and connects the two to different grounding circuits.

New 22-kV PMT: Key Development Considerations

(1) We substantially improved the insulation performance of the 24-kV switch by adopting vacuum insulation (a clean insulating medium) and substantially reduced the size of the equipment by incorporating three load-break switches and two grounding switches in a vacuum insulation switch for each separate phase. However, the vacuum insulation switch is inevitably larger than the vacuum valves used in the current vacuum circuit breakers. We therefore designed the vacuum insulation switch enclosure with an oval cross section to prevent concentrations of stress due to the difference in pressure between air in the outer part and vacuum in the inner part. We also changed the cable head connection. A bushing made of epoxy is usually used for this part, but epoxy resin does not hold up well to high temperature used when

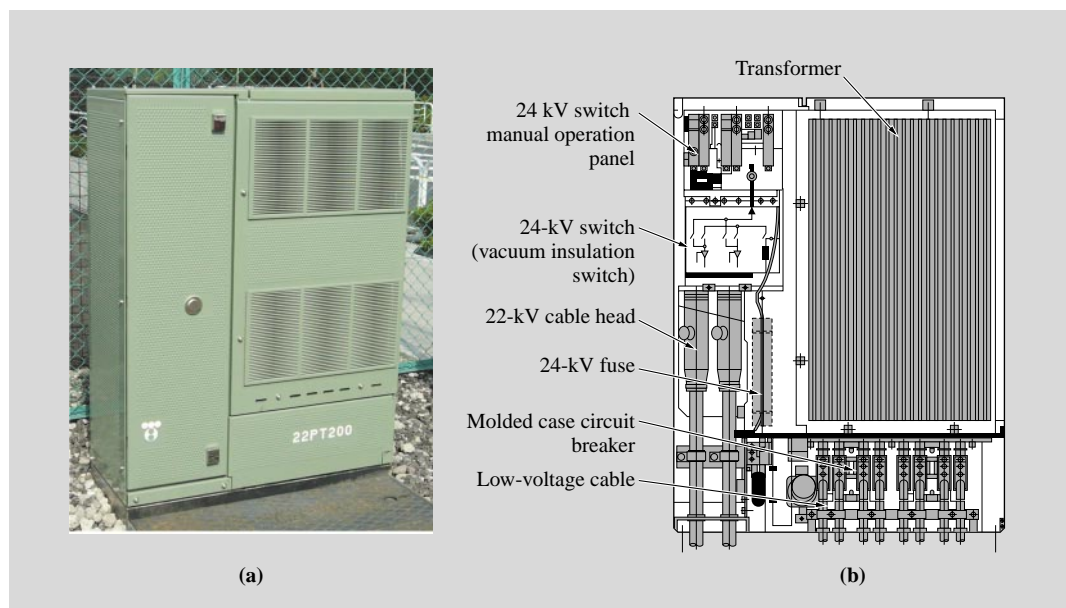

Fig. 9—22-kV PMT. External View of the new PMT (a) now being delivered to The Tokyo Electric Power Co., Inc., and internal structure (b) of the 22-kV PMT.

manufacturing the vacuum insulation switch, so for the connection we brazed a ceramic bushing onto the metal vacuum insulation switch.

(2) To reduce the size of the transformer, we mounted the molded case circuit breaker and low-voltage cable toward the front (the front of the conservator) at the bottom surface of the conservator used to absorb expansion of transformer oil. We also designed the transformer so that oil is supplied up to the top of the transformer by setting up the conservator behind the bottom of the transformer, thus enhancing the heat emission efficiency at the top of transformer (see Fig. 9). For the insulating oil we opted for silicon oil, which has a higher dielectric breakdown voltage and better withstands high temperatures than the conventional mineral oil.

CONCLUSIONS

In this paper we gave an overview of a 22-kV distribution system and highlighted the excellent performance of new 22-kV switchgear that Hitachi, Ltd. developed in cooperation with The Tokyo Electric Power Co., Inc.

The current distribution systems are predominantly 6 kV, but these will be progressively replaced by 22-kV distribution systems in the coming years. Given our heightened environmental awareness and the fact

that 22-kV distribution is relatively sustainable further underscores why this system will emerge as the predominant power distribution system in the years ahead.

While continuing to refine the technologies outlined here, Hitachi is committed to the rapid dissemination of 22-kV distribution technology not only to satisfy better the demand for power in Japan but also to make this advanced switchgear available in overseas markets.

ACKNOWLEDGMENTS

We would like to express deep appreciation for the support and encouragement provided by our colleagues at The Tokyo Electric Power Co., Inc. in the development of the 22-kV distribution equipment.

REFERENCES

- (1) T. Nakamura et al., "Technical Developments and Issues in the Widespread Deployment of 20kV Distribution," Transactions of the Institute of Electrical Engineers of Japan B (Aug. 2002) in Japanese.
- (2) S. Kajiwara, et al., "Development of 24-kV Switchgear with Multi-functional Vacuum Interrupters for Distribution," *Electrical Review*, Vol. 49, No. 2 (2000) in Japanese.
- (3) A. Morita et al., "Development of Compact Distribution Tower with 22kV/6.6kV 10 MVA LTC," Institute of Electrical Engineers of Japan, Research Committee on Switch Protection (Nov. 1999) in Japanese.

ABOUT THE AUTHORS



Shuichi Kikukawa

Joined Hitachi, Ltd. in 1997, and now works at the Switchgear Design Department, the Power & Industrial Systems Division, the Power Systems. He is currently engaged in developing power distribution equipment. Mr. Kikukawa is a member of The Institute of Electrical Engineers of Japan (IEEJ) and The Japan Society of Mechanical Engineers (JSME), and can be reached by e-mail at shuichi_kikukawa@pis.hitachi.co.jp.



Kenji Tsuchiya

Joined Hitachi, Ltd. in 1981, and now works at the Switchgear Design Department, the Power & Industrial Systems Division, the Power Systems. He is currently engaged in developing power distribution equipment. Mr. Tsuchiya is a member of IEEJ, and can be reached by e-mail at kenji_tsuchiya@pis.hitachi.co.jp.



Satoru Kajiwara

Joined Hitachi, Ltd. in 1991, and now works at the Switchgear Design Department, the Power & Industrial Systems Division, the Power Systems. He is currently engaged in developing power distribution equipment. Mr. Kajiwara is a member of IEEJ, and can be reached by e-mail at satoru_kajiwara@pis.hitachi.co.jp.



Akira Takahama

Joined Hitachi, Ltd. in 1984, and now works at the Electrical Solution Business Division, the Power & Industrial Systems Division, the Power Systems. He is currently engaged in developing power distribution equipment. Mr. Takahama is a member of IEEJ, and can be reached by e-mail at akira_takahama@pis.hitachi.co.jp.