

# High-performance Condenser Tube Cleaning System Featuring Advanced Ball Collecting Technology

Akihito Suzuki  
Kenchu Seki, Dr. Eng.  
Takeo Takei

*OVERVIEW: Power companies are faced with an increasingly harsh environment due to rapid deregulation and liberalization coupled and environmentally-friendly power generation, so maintaining the performance of condenser tubes that have such an enormous impact on the efficiency of power generation is emerging as a major issue. Since many of Japan's power plants use sea water for cooling, it is critically important to maintain condenser tubes used to cool large volumes of sea water in top performance by preventing marine life in the water from getting into and clinging in the tubes and keeping the tubes clean. These essential tasks are done by the condenser tube cleaning system. Pursuing R&D (research and development) based largely on the suggestions and guidance of various power companies, Hitachi has developed a high-performance tube cleaning system with the highest rated ball collecting ratio and installed the new system at Electric Power Development Co., Ltd.'s Isogo Thermal Power Station, Unit No. 1 and Tohoku Electric Power Co., Inc.'s Higashidori Nuclear Power Station, Unit No. 1. Based on accumulated knowledge and expertise in this area, we have now developed the world's largest-class practical ball strainer and recently finished installing the new system at Hokuriku Electric Power Company's Shika Nuclear Power Station, Unit No. 2.*

## INTRODUCTION

CONDENSERS consist of many tubes for cooling and condensing the exhaust steam from steam turbines. A condenser tube cleaning system (hereafter simply tube cleaning system) is a closed recirculating loop in which sponge cleaning balls (hereafter cleaning balls) are injected into the condenser cooling water. The cleaning balls pass through the tubes and polish and clean the inner tube surface. The cleaning balls are then collected by ball strainer that is located downstream from the condenser tubes and re-injected by a ball recirculating pump through ball injection nozzle installed on the condenser cooling water inlet pipes. Especially considering the growing importance and awareness of environmental protection, it is essential to prevent the cleaning balls from getting out of the closed loop system and increase the cleaning ball collecting ratio as high as possible. These concerns led Hitachi to conceive a tube cleaning system that is easy to operate on a continuous basis without any of the cleaning balls escaping from the system by implementing a new type of ball strainer that works with grids that are

continuously closed and a ball-shell separator (see Fig. 1). Having had excellent results with this approach on installations, we are now supplying the system on larger capacity condensers. This paper provides a descriptive overview of the tube cleaning system and its performance.

## OVERVIEW OF EQUIPMENT

### Condenser Specifications

Tube cleaning systems are specifically engineered to polish and clean condenser tubes. Condenser tubes vary depending on the capacity of the power plant, but tubes to accommodate the largest class nuclear power plant have a cooling surface of 102,000 m<sup>2</sup> and a total tube length (i.e. length × number of tubes) of over 1,100 km (see Table 1).

### Tube Cleaning System

The tube cleaning system basically consists of cleaning balls that are slightly larger in diameter than the condenser tubes. The balls are suspended and pass through the cooling water to clean and polish the inner



(a)  
Ball strainer with flapping screen  
(shell diameter:  $\phi 3,500$  mm)



(b)  
Large-capacity ball strainer  
(shell diameter:  $\phi 4,400$  mm)

Fig. 1—High-performance Ball Strainer and Large-capacity Ball Strainer.

(a) Ball strainer with flapper for Tohoku Electric Power Co., Inc.'s Higashidori Nuclear Power Station, Unit No. 1, and (b) large-capacity ball strainer for Hokuriku Electric Power Company's Shika Nuclear Power Station, Unit No. 2. Hitachi is unique in being the only domestic Japanese company that manufactures its own condenser tube cleaning systems, many of which are up and running at thermal and nuclear power plants in Japan and around the world.

TABLE 1. Main Specifications of Condenser for 1,350-MW Capacity Nuclear Power Plant  
Large-capacity condensers with cooling area of 102,000 m<sup>2</sup> and total tube length (length  $\times$  number of tubes) of 1,100 km.

Item		Specification (per 3 shells)
Type		3-shell surface type
Cooling surface		102,000 m <sup>2</sup>
Tube	Diameter	28.58 mm
	Thickness	0.5 / 0.7 mm
	Effective length	17,790 mm
	No. of tubes	63,864

surface of the tubes. Typically this is done once or twice a day, and the length of the cleaning ball recirculating loop is four to five times the effective length of the condenser tubes. Assuming that the cleaning balls pass through the condenser tubes about five times in one operation, they travel a total distance of over 22,000 km in a single operation.

Typically, the number of cleaning balls is about 10% of the number of condenser tubes, and our

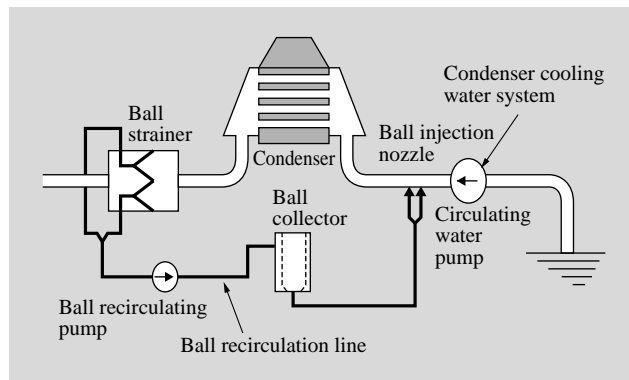

Fig. 2—Basic Structure of Tube Cleaning System.

System consists of a ball strainer, ball recirculating pump, ball collector, ball injection nozzle, tubing, and valves.

objective is to achieve a cleaning ball collecting ratio after a cleaning operation of 100%. Fig. 2 shows the configuration of a typical cleaning tube system. One can see in the figure that the main components of the system are:

- (1) a ball injection nozzle for injecting balls into the cooling water at the condenser inlet,
- (2) a ball strainer for collecting the cleaning balls from

- the cooling water flow at the condenser outlet,
- (3) a ball recirculating pump that delivers the balls collected by the ball strainer back to the front of the condenser tubes, and
- (4) a ball collector that stores and releases the cleaning balls into the condenser tubes.

**STATE-OF-THE-ART FUNCTIONS AND FEATURES**

**Ball Strainer**

The ball strainer installed in the cooling water return pipe downstream from the condenser is the most important component of the system, for it captures the balls after cleaning and returns them to the condenser inlet pipes via the ball recirculation line. The strainer section includes two grids forming a V-shaped ridge that are kept closed (in capture mode) while the cleaning system is in operation. The balls are collected in the grid valley, then are directed to the ball recirculation line without restricting the cooling water flow. Because the standard operating time is 1-2 hours and balls are not recirculated outside of the operating time, the grid is opened to prevent increasing pressure drop due to accumulated marine life at the ball strainer grid.

On the other hand, the balls travel a considerable recirculation distance, as we observed earlier. If balls stagnate en route along the condenser cooling water line, then they might be late in arriving, thus making it likely that the balls will not all be collected by the ball strainer within the typical operation time period. To address this contingency, we conceived a ball

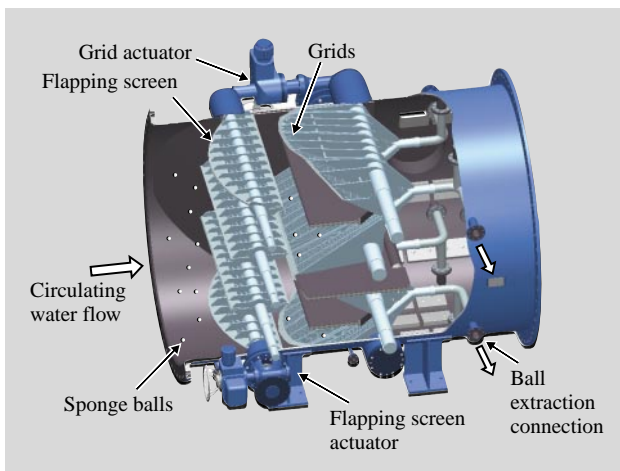

Fig. 3—Overview of Ball Strainer with Flapping Screen. A high-performance ball strainer is implemented by mounting a flapping screen on the upstream side of a conventional ball strainer.

strainer with flapping screen that prevents any loss in the ball collecting ratio and prevents balls from escaping the system (see Fig. 3).

In order to collect the late-arriving balls mentioned in the previous paragraph, the ball strainer grids must be kept in a closed (capture mode) state. However, if a conventional ball strainer is operated in an always closed (capture mode) state, this causes two major problems:

- (1) If the ball strainer is operated in a closed (capture mode) state for a prolonged period, marine life and debris accumulate on the surface of the grids, and this is what causes the cleaning balls to stagnate or remain uncollected.
- (2) Grid pressure loss increases as a result of incoming debris accumulation, thus causing the grids to open at unpredictable intervals regardless of the operating state of the tube cleaning system.

To address these issues, we developed the ball strainer with rotating flapping screen mounted on top of conventional V-shaped grids. The movement of the flapping screen separates balls stagnating on the grids so they can be collected. This structure in which the

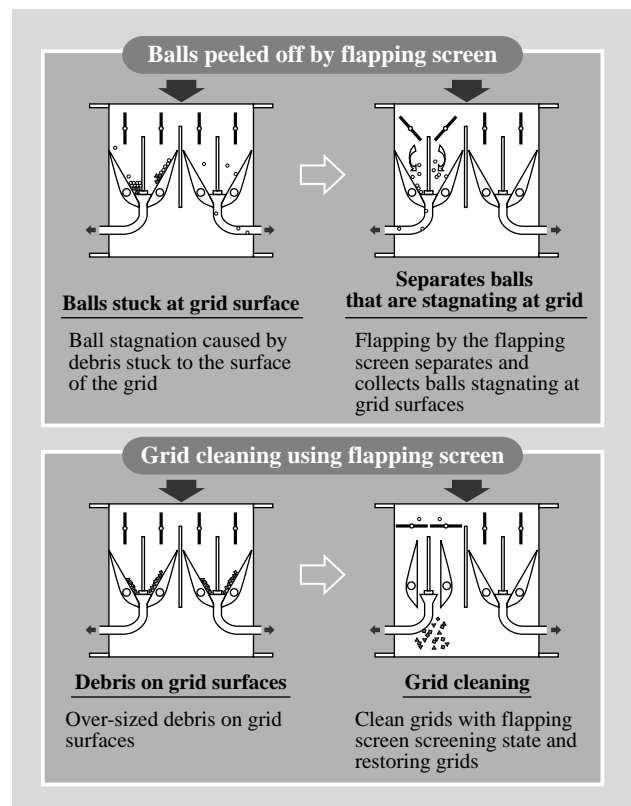

Fig. 4—Operating Principle of Ball Strainer with Flapping Screen. Flapping of the flapping screen collects cleaning balls stuck at the screen and cleans grids.

grids can be open while flapping screens are closed (capture mode) represents a breakthrough, because it enables fouling debris to be washed away from the grids without any balls escaping from the system. Fig. 4 illustrates the operating principle of the ball strainer with flapping screen.

### Ball-shell Separator

Another problem of operating with the ball strainer grids in an always closed (capture mode) state is that this permits the inflow of marine life and other kinds of debris. When debris is recirculated along with the cleaning balls and reinjected into the condensers, this causes the balls to stagnate along with the marine life in the inlet of the condenser tubes. This is the major factor responsible for reduced ball collection ratio. To remedy this, we developed a ball-shell separator that separates the debris that is collected along with the cleaning balls by the ball strainer then only recirculates the cleaning balls. The ball-shell separator uses the different specific gravities of the balls and shell to separate out the debris that is collected together with the cleaning balls by the ball strainer using a rotating blade and spiral slits in the separator. The balls are continuously sent to the ball injection nozzle and recirculated, while the separated debris accumulates at the bottom of the separator, and is discharged downstream of the ball strainer when a certain amount of debris accumulates. Fig. 5 illustrates how the ball-shell separator works.

### APPLICATION OF NEW TECHNOLOGIES

The first installation of our high-performance tube cleaning system featuring the ball strainer with

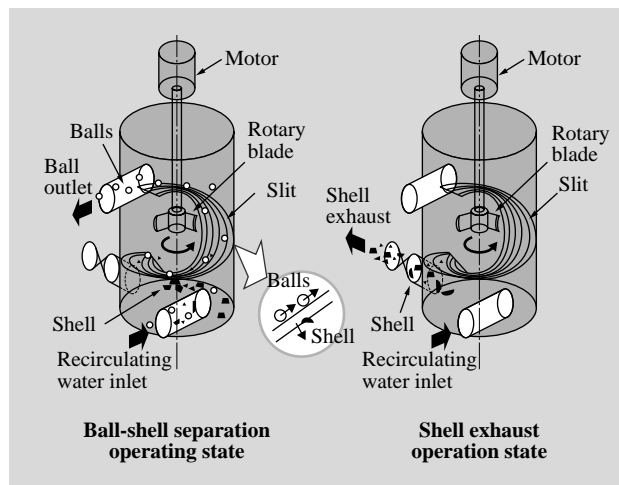

Fig. 5—Principle of Ball-shell Separator.

Balls and shell are separated by revolving flow and spiral slit using different specific gravities of the shell and balls.

flapping screen and the ball-shell separator was carried out on Electric Power Development Co., Ltd.'s Isogo Thermal Power Plant, Unit No. 1 and is now in commercial operation. Subsequently, a large-capacity ball strainer with flapping screen designed for nuclear power plants was deployed at Tohoku Electric Power Co., Inc.'s Higashidori Nuclear Power Station, Unit No. 1, and the plant is now in commissioning operation. Table 2 shows the specifications of the condensers and tube cleaning systems at the two plants.

### APPLICATION OF NEW TECHNOLOGIES: RESULTS

Excellent ball collecting ratios were recorded at both plants during commissioning operation. We also confirmed that when operating with the ball strainer

TABLE 2. Comparison of High-performance Ball Strainer Specifications  
Main specifications of the Electric Power Development Co., Ltd.'s Isogo Thermal Power Station, Unit No. 1 and Tohoku Electric Power Co., Inc.'s Higashidori Nuclear Power Station, Unit No. 1.

Item		Isogo No. 1 (new)	Higashidori No. 1
Plant overview	Output	600 MW	1,100 MW
	Startup	April 2002	Oct. 2005 (scheduled)
Condenser	Manufacturer	Fuji Electric Holdings Co., Ltd.	TOSHIBA CORPORATION
	No. of units	1 shell 2 water boxes	3 shells 6 water boxes
	Tubes	Titanium (TTH340W)	Titanium (TTH340W)
	Cooling water	Sea water	Sea water
Ball strainer	Type	Single stage curved grids with straighten vane (with flapping screen)	Single stage curved grids with straighten vane (with flapping screen)
	Shell diameter	φ2,400 mm	φ3,500 mm
	Shell length	3,500 mm	4,500 mm
	No. of units	2	3
	Flow volume	42,000 m <sup>3</sup> /h	91,200 m <sup>3</sup> /h
Ball-shell separator	Type	Agitation separation type	Agitation separation type
	Shell diameter	φ1,000 mm	φ1,000 mm
	No. of units	2	6
	Flow volume	160 m <sup>3</sup> /h	320 m <sup>3</sup> /h

grids always closed (capture mode), the uncollected balls stagnating in the condenser cooling water line were collected as late-arriving balls, and none of the balls escaped from the system.

### LARGE-CAPACITY BALL STRAINER

Based on the promising results outlined above, Hitachi contrived a high ball collecting ratio system including a ball-shell separator with conventional ball strainers for deployment at Hokuriku Electric Power Company's Shika Nuclear Power Station, Unit No. 2, and this is the largest working ball strainer that has been implemented to date. The specifications of this system are summarized in Table 3.

TABLE 3. Main Specifications of Large-capacity Ball Strainer  
Main specifications of the Hokuriku Electric Power Company's Shika Nuclear Power Station, Unit No. 2 are shown.

Item		Shika No. 2
Plant overview	Output	1,358 MW
	Startup	March 2006 (scheduled)
Condenser	Manufacturer	Hitachi
	No. of units	3 shell 6 water boxes
	Tube	Titanium (TTH340W)
	Cooling water	Sea water
Ball strainer	Type	Single stage curved grids with straighten vane
	Shell diameter	φ4,400 mm
	Shell length	5,500 mm
	No. of units	2
	Flow volume	159,500 m <sup>3</sup> /h
Ball-shell separator	Type	Agitation separation
	Shell diameter	φ1,000 mm
	No. of units	1
	Flow volume	267 m <sup>3</sup> /h

### CONCLUSIONS

This paper provided an overview of condenser tube cleaning equipment developed by Hitachi. The growing environmental effects of global warming demand more efficient generation of power in the years ahead, and this calls for the maintenance of condenser performance since condensers have an enormous impact on power generation efficiency. Hitachi is in the unique position of being the only manufacturer in Japan to make its own condenser cleaning systems,

and is committed to developing even higher performance equipment and systems to address diverse needs in the years ahead.

### ACKNOWLEDGMENTS

We would like to express my appreciation to the power companies and other interested parties for their guidance and cooperation in the development and deployment of Hitachi's high-performance large-capacity condenser tube cleaning systems.

### REFERENCES

- (1) S. Kaneko et al., Patent No. 3302897, "Heat Exchanger Tube Cleaning System and Operation Method," registration date; April 26, 2002, in Japanese.
- (2) S. Kaneko, et al., Patent No. 3318224, "Rotary Blade Type Debris-Cleaning Object Separator," registration date; June 14, 2002, in Japanese.

### ABOUT THE AUTHORS



**Akihito Suzuki**

Joined Hitachi, Ltd. in 1992, and now works at the Condensing & Feed Heating Equipment Design Section, the Thermal Power Plant Design Department, Hitachi Works, the Power Systems. He is currently engaged in engineering work on condensers, feedwater heaters and condenser ball cleaning system for steam turbines. Mr. Suzuki can be reached by e-mail at [akihito\\_suzuki@pis.hitachi.co.jp](mailto:akihito_suzuki@pis.hitachi.co.jp).



**Kenchu Seki**

Joined Hitachi, Ltd. in 1997, and now works at the Condensing & Feed Heating Equipment Design Section, the Thermal Power Plant Design Department, Hitachi Works, the Power Systems. He is currently engaged in engineering work on condensers, feedwater heaters and condenser ball cleaning system for steam turbines. Dr. Seki can be reached by e-mail at [kenchu\\_seki@pis.hitachi.co.jp](mailto:kenchu_seki@pis.hitachi.co.jp).



**Takeo Takei**

Joined Hitachi Engineering & Services Co., Ltd. in 1990, and now works at the Condenser Cleaning System Section, the Power Plant Division. He is currently engaged in engineering work on condenser ball cleaning system and debris filer for steam turbines. Mr. Takei can be reached by e-mail at [takei\\_takeo@mail.hesco.hitachi.co.jp](mailto:takei_takeo@mail.hesco.hitachi.co.jp).