

Healthcare Systems/
Biotechnology



Industrial Systems

- Industrial Systems
- Steel and Chemical Plants
- Environment
- Public Facilities
- Automotive Systems
- Transportation
- Building Systems
- Semiconductor Manufacturing
and Inspection Equipment

Power Systems

Information Systems

HIGHLIGHTS

Car Navigation Evolving Toward a Safer, More Reliable, and More Comfortable Motorized Society

2006-2007

As the telecommunication network and transport infrastructure become increasingly developed, Hitachi Group decided to strengthen the business field of the CIS, and to accelerate the evolution of car navigation system and its role toward safer, more reliable and more comfortable motorized society.



Tomoaki Nakamura (left), Director CTO, HCX Corporation; Akio Sumizawa (middle), General Manager, Technical Development Center, Prior Development Headquarters, Xanavi Informatics Corporation; Hirohisa Miyazawa (right), Technical Development Center, Prior Development Headquarters, Xanavi Informatics Corporation

What is the Appeal of the Latest Car Navigation System Models?

Optimal route guidance feature won many users' reputation, provides significantly higher accuracy than the existing one, based on the Hitachi Group's unique traffic prediction technology. Since conventional practice uses the real-time traffic information sent from VICS (vehicle information and communication system) center and map information. It has a problem of road coverage. Fully used the extensive know-how of the Hitachi's research activities, Xanavi has developed an advanced technology that performs traffic jams estimations on all roads through the statistical processing of VICS information obtained over the past years. Thus the traffic jam estimation with higher accuracy for each hour and day of the week on all roads has been enabled. Combined with this advanced technology and the conventional real-time traffic information, the optimal route guidance feature minimizes the travel time to destination and also provides the significantly improved estimation of

arrival time. The company will continue to commercialize new models of car navigation systems including this feature in Europe, the U.S.A., and Asia successively.

Xanavi mainly has provided OEM (original equipment manufacturer) products to the major car manufacturer in Japan, mounted in automobiles at their factory. Highly valued for its functionality and contribution, Xanavi received an innovation Award in 2005 recognized as one of the most valuable suppliers, from the major car manufacturer in Japan. Not only in Japan, also in Europe and the U.S.A., Xanavi has been accepted as a major supplier to manufacturers of onboard navigation system, and continuously expands its reputation towards a globally competitive company.

What is Happening to Car Navigation in the Near Future?

The progress of the information technology is making great strides in motorized society as well. With the introduction of the ITS car navigation, not only route guidance function, but also the advanced features equipped with telecommunication capabilities are emerging. Xanavi has joined the "Sky project" that involves field testing of the ITS to be conducted in Kanagawa Prefecture in 2006. In this project, car navigation will have the new feature to attempt to prevent traffic accidents and reduce traffic jams by using bi-directional communication between cars and traffic infrastructures. More specifically, several interesting experiments will be planned, such as on how to deviate traffic jams by warning drivers of incoming vehicles at an intersection, reminding drivers to observe speed limits in school zones and other areas of high pedestrian traffic, and "probing" location and vehicle information and send them to the traffic server. Even real-time micro weather forecast could be possible by monitoring the windshield wiper behavior of millions of cars.

Hitachi, Ltd. and Clarion Co., Ltd. established a comprehensive cooperation scheme in the CIS (car information systems) business in May 2005. It covers major supply chain activities such as R&D, procurement, production, sales, service and support. They also greatly increased the work force of HCX Corporation, a joint venture of the two companies, as a core development center for the 2008 and beyond model year products. By combining the IT (information technology) and automotive technology of the Hitachi Group with the car audio technology of Clarion, HCX will accelerate the development of car navigation products with high functionality, performance, and highly value-added features for the global market. To achieve the evolution of car navigation, highly reliable technologies related to both onboard equipment and server systems are required. Xanavi and Clarion will utilize the extensive expertise of the Hitachi Group and realize the safer and more comfortable motorized society.



Latest models of car navigation systems

HIGHLIGHTS

Development of Japan's First Full Automatic Operation System for Subway and Series 3000 Train, Introduced in the Fukuoka City Transportation Bureau's Nanakuma Line Subway

2006-2007

The Fukuoka City Transportation Bureau's Nanakuma Line Subway that began service on February 3, 2005, is Japan's first subway line compatible with full automatic operation. Hitachi, Ltd. delivered a traffic control system and a train system to the project, helping to build a full automatic operation system for safe and efficient traffic. Hitachi also compiled the results of train developments, the first case of their kind, and took advantage of its long-cultivated experience and expertise to become a total integrator of railroad equipment. The company thus realized trains that combine the functional requirements for full automatic operation with excellent design performance and comfort.

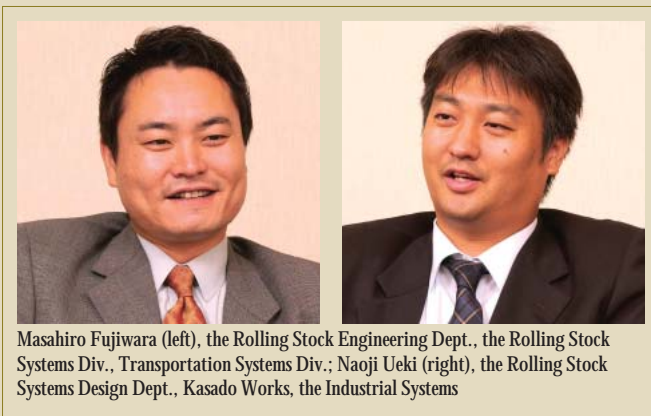

Masahiro Fujiwara (left), the Rolling Stock Engineering Dept., the Rolling Stock Systems Div., Transportation Systems Div.; Naoji Ueki (right), the Rolling Stock Systems Design Dept., Kasado Works, the Industrial Systems

What are the Points of Full Automatic Operation in Subways?

Full automatic operation has already been introduced in new transport systems and similar facilities, but the Fukuoka City Transportation Bureau's Nanakuma Line Subway was the first to actually adopt such operation. Since subway trains run in enclosed tunnels, there had been concerns over the possible difficulty in taking refuge should a train be stopped between stations. For that reason, the present project for the full automatic operation system paid the greatest attention to three points: not allowing a train to stop between stations, not causing passengers needless worry, and ensuring stable travel. In so doing, Hitachi committed itself to building the system and equipment.

The greatest difference between the new system and conventional train control systems is that, in the event of an incident, the train reaches the next station, whenever possible, without stopping between stations. To that end, the units of train equipment related directly to travel consist of a dual system or a two-unit system, thus allowing one to run even if the other fails.

The traffic control system also employs a dual configuration for its main devices and constantly monitors the train status. Should a train fail, the on-board train operator enables cooperation with the personnel aboveground in order to take prompt action.

Full automatic operation is based on ATO (automatic train operation) and enables very precise operation control. Hitachi can safely say that a reliable, safe, and fully automatic operation system has been realized through a different way of thinking and a comprehensive review of conventional information transmission practices.

What are the Features of the Train?

The trains for the Nanakuma Line feature a new design based on the concept of friendliness to people and the environment.

Compared to the commuter trains used for the old lines, this new train is three-fourths smaller in terms of length. However, the multiple configurations of train equipment described above require about double the amount of wiring. We brainstormed to find a way to manage the trains and eventually succeeded in combining a neat design with functionality by reducing the equipment size, considering an ingenious layout, and employing other features.

Conventionally most train equipment is developed by placing specific orders with respective manufacturers for a chassis, main circuit controls, motors, and air conditioners, and then having railroad operators organize their own projects. However, in the present project, we encountered the very first case where Hitachi, Ltd. received a collective set of orders and developed a completely new design. We were keenly aware that this new experience of developing the train in collaboration with members and non-members of the Hitachi Group would prove very valuable and beneficial.

What are the Prospects?

For the Nanakuma Line, the traffic control system and train system—the very core of full automatic operation—were undertaken by Hitachi, Ltd. In addition, the company received a collective set of orders for all trains. We believe that all this happened because the client valued our capability resulting from long years of our comprehensive engagement in railroad projects. In the railroad field, the capability for providing such total solutions will be required more and more. We intend to continue enhancing our expertise in order to make our recent experience more useful in the future.



The series 3000 train delivered to the Fukuoka City Transportation Bureau's Nanakuma Line Subway



Hitachi Energy Solution Service in South East Asia

The Kyoto Protocol, COP3, determined at the third session of the Conference of the United Nations Framework Convention on Climate Change, has been in effect since February 2005. According to COP3, Japan has to reduce 6% of its emission of global warming gases between 2008 and 2012, compared to its levels in 1990. To meet this goal, the Japanese government has enacted several regulations for energy conservation, environmental taxes, emissions trading of carbon dioxide, and so on. This means that most companies and municipalities are required to severely reduce CO₂ emissions, energy costs, and capital assets.

Recently, the business of ESCOs (energy service companies) has been growing, and they have been providing customers with comprehensive services for energy savings. Hitachi started an ESCO business in April 1999, and it currently is involved in about 100 projects.

The ESCO has a new business scheme that offers comprehensive services for energy savings to customers and covers the cost

required to repair energy-saving equipment with the money saved by the energy saving. The service includes an energy saving diagnosis, energy saving proposal, equipment installation, finance, and maintenance.

Reducing carbon dioxide emissions is very important; however, customers request not only reduced carbon dioxide emission, but also reduced energy costs and reduced costs of products for improving ROE (return on equity).

The Hitachi's ESCO manages to comprehensively reduce carbon dioxide emissions and to save more energy and product costs compared with projects promoted by customers themselves. Therefore, it can effectively trade surplus CERs (certified emissions reductions) and improve ROE.

The following are advantages of working with the Hitachi's ESCO to save energy costs: (1) total execution of energy-saving modifications, (2) reliable advantage with only a flat service fee, (3) effective investment for core business to improve ROE, through capital asset reduction.

Additional characteristics of Hitachi are as follows:

(1) Hitachi already produces various products for energy saving and has experience in various fields all over the world.

(2) A monitoring system has been established for cogeneration and other energy saving systems in Japan and has been expanded to South East Asia.

(3) Hitachi has profound knowledge of its products and knows when maintenance should be done.

Hitachi has started an ESCO with Hitachi Asia Ltd. in South East Asia. Its first project is the Energy Saving Service of Hitachi Global Storage Technologies Philippines Corp. as shown in the figures below.

In this project, Hitachi installed a waste heat recovery system in an ordinary diesel engine generator so that the waste heat of the engine jacket water and exhaust gas are converted into cooling chilled water by efficient hot water and steam absorption chillers. The energy saving value is about one thousand kiloliters per year in crude oil.

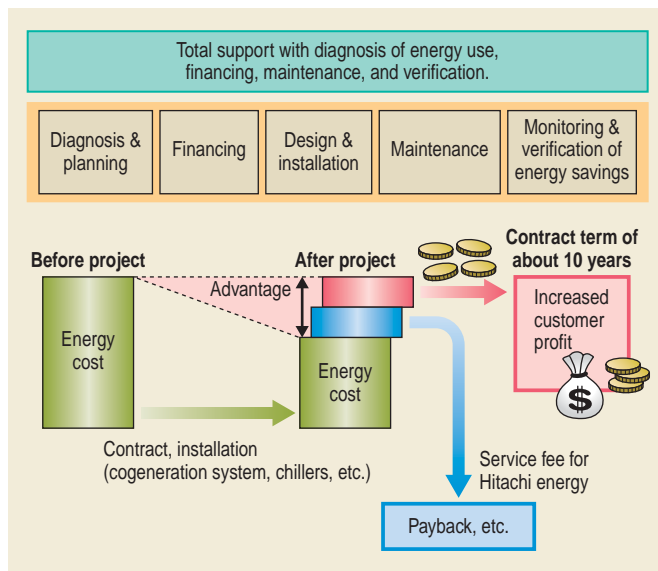

Concept of ESCO business

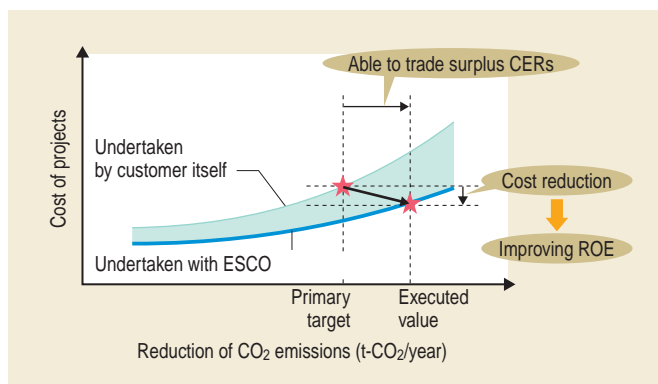

Goal of ESCO business



Exhaust heat steam boiler



Steam absorption chiller



Environmentally Friendly Gas Insulated Switchgear

The International Conference on Global Warming in December 1997 called for the reduction of SF₆—the common gas used in GIS (gas-insulated switchgear)—because it is a greenhouse gas, and this Kyoto Protocol became a legally binding treaty on February 16, 2005. Committed to provide an environmentally friendly GIS, Hitachi was first to develop and deploy dry-air-insulated switchgear based on a VCB (vacuum circuit breaker) and dry-air insulation technology, and this new system was put into service in June 2005. Building on this success, we are now moving toward completion of an environmentally friendly substation that uses a silicon oil transformer.



Environmentally friendly GIS (72-kV rated voltage, 800-A rated current, and 25-kA/2-s rated short-time withstand current)



Hitachi Industrial PC

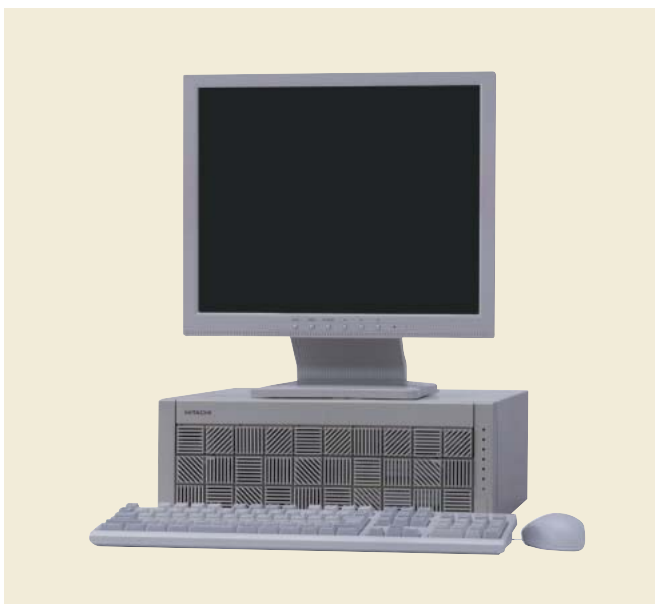

HF-W6500 model 20

Hitachi has now released HF-W6500 model 20, a PC designed for industrial and manufacturing uses. The PC has high reliability and can be used in communications and semiconductor fab line systems where processing performance, reliability, and maintainability are critically important.

[Main features]

- (1) Designed for high reliability, the PC can run 24 hours, 365 days a year for ten years.
- (2) Long-term availability of the same computer model guaranteed for at least three years after the model first goes on sale
- (3) High-performance, low power consumption Intel Pentium® M 745 (1.8 GHz) is adopted.
- (4) ECC (error check and correction) memory is used for high reliability.
- (5) Fault monitoring and analysis services are available.
- (6) Hardware RAID (redundant array of independent disks) is available.
- (7) Fully compliant with RoHS (restriction of hazardous substance) directives
- (8) Compliant with UL, CSA, CE, FCC, and CCC international standards

* See "Trademarks" on page 94.



High-speed PXR Series Inkjet Printers for Manufacturing Lines



High-speed inkjet printer PXR-H450W for manufacturing lines

Hitachi has now launched the industrial inkjet printer PXR series to meet the demanding requirements of customers in the beverage, food, cable, and steel industries for high-speed printers on fast-moving manufacturing lines.

[Main features]

(1) The PXR series features a newly designed nozzle and enhanced electronic control over ink droplets deposition. The number of ink droplets used in printing has been substantially increased to 95,200 per second, approximately 1.4 times more than on the previous model. Two-line printing performance is more than adequate to keep up with the fastest manufacturing lines in the world moving at 150 m/min.

(2) Hitachi also developed new specifications for the print-head and ink droplet control scheme specifically for this line. The printer produces exceptional print quality even on the fastest moving manufacturing lines.

(Hitachi Industrial Equipment Systems Co., Ltd.)



Large Air-cooled Two-stage Oil-free Screw Air Compressor

Oil-free screw air compressors are used in many industries that have environment-related needs, such as food and chemical factories which require oil free air. Large air-cooled models, 132–240 kW, have been newly developed.

[Main features]

(1) Newly developed air end enables the highest performance in this air-cooled model.

(2) Low noise design is achieved by improved vibration proof structure for the drive train components. In addition, the noise of the intake and exhaust air for the cooling air is also reduced. Even if it is compared with the water-cooled model, the noise level is still competitive.

(3) Coolers are installed in parallel and on the angle like V-shaped. Space saving design is achieved by this unique cooler layout and downsized gear case.

(4) The new air ends and Hi-precooler system enable the discharge pressure to be up to 1.0 MPa.

(5) No water quality management is required, and the structure enables easy cleaning of coolers.

(Hitachi Industrial Equipment Systems Co., Ltd.)

(Sales started: December 2005 for export)



Large air-cooled two-stage oil-free screw air compressor



High Energy-saving Super Amorphous Transformers

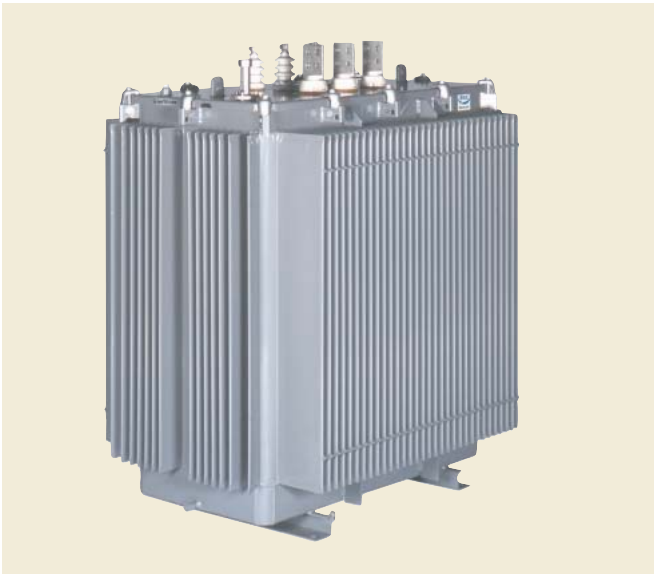

Compact super amorphous transformer

In an effort to reduce energy losses and greenhouse gas emissions, the Japanese government enacted the Energy Saving Law, designating amorphous metal transformers for their high energy saving potential, and declared 2006 the target year to achieve the top runner standard of 30% loss reduction over conventional oil-immersed transformers.

Hitachi's compact and lightweight super amorphous transformer was the breakthrough needed to finally achieve the top runner standard, and this series of transformers is now available on the market. By substituting amorphous alloy for the core material, we have now exceeded the top runner standard by more than 30%, and have developed a whole line-up of super amorphous transformer products to help conserve energy and reduce greenhouse gas emissions.

(Hitachi Industrial Equipment Systems Co., Ltd.)



Electrical Equipment for Advanced Continuous Pickling Cold Rolling Delivered to BNA in China

Electrical equipment for advanced continuous pickling cold rolling delivered to Baosteel-NSC/Arcelor Automotive Steel Sheets Company (BNA) in Shanghai, China, is now in commercial operation and running smoothly.

BNA is a joint venture among Baosteel, Nippon Steel, and Arcelor, and this cold rolling equipment is the first installed at the company. The new equipment will be used to produce a full range of steel sheets from 0.35-mm thin sheets to medium-thickness high grade steel sheets for car bodies. The combination of high-response multi-functional 10-MVA high-voltage IGBT (insulated gate bipolar transistor) drive equipment with a strip-thickness control system based on optimum control theory, enables the company to produce high-precision and uniform-quality steel sheets over their entire length. Strip shape quality and operation stability have also been markedly improved through the introduction of a new strip shape control technology. A key advantage of this new shape control scheme is that it supports precise control all the way to the edges of strips and well beyond the range of the previous system, so now precision shape quality is extended over the entire width of steel sheets.

(Start of commercial operation: March 2005)



Central operation room (above) and high-voltage IGBT drive equipment (below)



Double Cold Reduction Mill for Baoshan Iron & Steel Company, China

A DCR (double cold reduction) mill was delivered to Baoshan Iron & Steel Company (Baosteel) in China and has been up and running smoothly since February 2005. China's first DCR/temper 2-stand tandem mill for the production of DR (double reduction) tinplate, the equipment is a 6-high UC (universal crown) mill that can readily change work-roll diameter, supports both dry and wet production modes, and features the latest electronic control technology that is capable of producing very thin sheets to a gauge of only 0.1 mm. The sheet gauge precision across the entire coil including head and tail ends is significantly improved by introducing a high-performance multi-functional IGBT (insulated gate bipolar transistor) drive unit and high-precision gauge control technology for application to ultra-thin rolling. By adopting a new shape control technology that optimally controls the work-roll and intermediate-roll bender, shape control has been markedly enhanced while maintaining excellent operation stability.



One-person operation in the main control room (above), the mill equipment and cold-rolled coils (below)



Six Hitachi-supplied Processing Lines Commence Operation in Overseas Markets

Fiscal 2005 saw a succession of six Hitachi-supplied steel mill lines commence operation in overseas markets: a continuous annealing line and No. 1 continuous galvanizing line for Shanghai-based Baosteel-NSC/Arceleor Automotive Steel Sheets Company (BNA), the No. 2 continuous annealing line and No. 5 continuous galva-

nizing line for Pohang Iron & Steel Company (POSCO) in Korea, and a continuous galvanizing line and continuous coating line for Hyundai Hysco also in Korea.

All this investment reflects a growing demand for cold-rolled steel sheets as building material and to manufacture cars. To ensure high quality, precision tension control was implemented based on Hitachi's responsive multi-functional IGBT (insulated gate bipolar transistor) drive equipment. The effectiveness of Hitachi's SPM (skin pass mill) shape control deployed at BNA's continuous annealing line is also clearly apparent, for the continued praise this and the other companies receive for the steel sheets supplied to the auto makers who have a very exacting standard of quality.



Operation control room (left) and delivery equipment (right)



World's Largest Class Mammalian Cell Culture Plant Supplied to Chugai Pharmaceutical Co., Ltd.

Antibody therapeutics based on genetic information and sophisticated protein processing technology has been developed extensively because of its high efficacy and low side-effect potential. To produce high molecular-weight antibody therapeutics in intact condition, reliable and highly productive mammalian cell cultures are indispensable.

Hitachi supplied a first-phase antibody production plant in Utsunomiya, Japan in September 2002 for Chugai Pharmaceutical Co., Ltd., which was the largest Japanese mammalian cell culture plant. The world's largest class scale antibody therapeutics manufacturing plant was supplied as the second-phase plant in May 2005.

This second-phase plant was engineered using Chugai's improved manufacturing process and Hitachi's proven fermentation technology with computational fluid dynamics. The manufacturing process includes six 10-kL cell culture reactors, cell separation, column chromatography, tangential flow filtering, and bulk filling. Hitachi provided engineering, procurement, construction, and validation services complying with current good manufacturing practices for the entire plant.

Significant productivity enhancement is expected using the

improved process and optimized equipment through full-load operation.



World's largest class mammalian cell culture plant: six 10,000-L scale mammalian cell culture reactors



CDM/JI: Emission Reduction Projects with International Partners

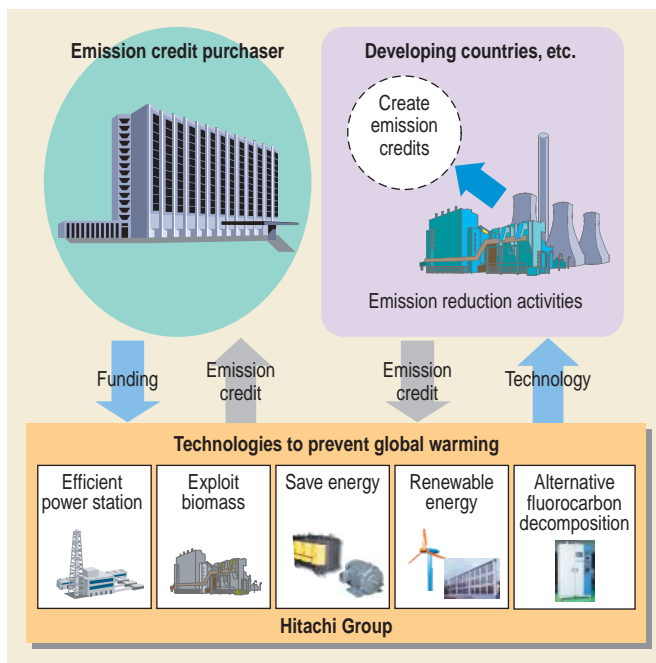

Overview of international projects (CDM/JI) to roll back global warming

The Kyoto Protocol committing the advanced industrialized nations to curtail and roll back greenhouse gas emissions went into effect in February 2005. Japan would find it extremely difficult to meet its emission reduction target of -6% based upon domestic projects alone, and is thus seeking to obtain emission credits through public and private emission reduction projects with international partners through the CDM/JI (Clean Development Mechanism and Joint Implementation) arrangements provided for in the Kyoto Protocol.

The Hitachi Group is recognized for its many energy-saving products and systems designed to reduce or decompose greenhouse gases, and now Hitachi is moving aggressively through the CDM/JI to transfer these products and systems to other countries. Specifically, Hitachi is formulating CDM design documents for submission and approval by the United Nations to conduct emission reduction projects in collaboration with international partners. We are pursuing this approach not only to help Japan meet its emission target in a cost effective way, but also to help roll back global warming by transferring our technological knowhow overseas and to assist developing countries achieve sustainable development.



Central Monitoring and Control System Deployed at Niwakubo Water Purification Plant in Osaka Department of Waterworks

Department of Waterworks Osaka Prefectural Government Mishima and Expo Park water purification plants (with a combined processing capacity of 330,000 m³/d) have been converted to

unmanned facilities thanks to the deployment of a remote monitoring and control system. The satellite plants are now controlled through a central monitoring and control system installed at the Niwakubo Water Purification Plant.

[Main features]

- (1) Remote monitoring and control using a LAN for communication among the various plants over independent wireless links.
- (2) Reliability is assured with redundant implementation of wireless links and monitoring equipment.
- (3) In addition to the control LAN, another wireless LAN is deployed for exchanging information and accessing the plants.
- (4) The system includes fault monitoring to pinpoint network failures.

(System began operating: January 2006)

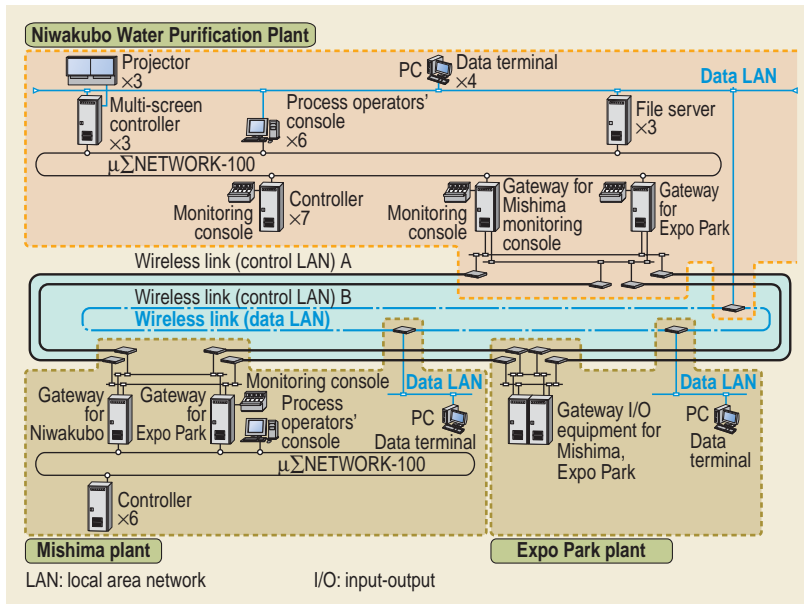

Configuration of the new monitoring and control system



Membrane Filtration Operation Control System for Water Treatment

A growing number of medium- to larger-scale water purification plants are planning to introduce membrane filtration processes not only to enhance the efficiency of their plant operations management but also to better filter out protozoan pathogens. In membrane filtration processing, the distribution of water flow through numerous membrane filtration units, the amount of pre-treatment, and the operation of the membrane filtration equipment are all closely interrelated in a complex way, so it's essential that the various operating conditions are properly set considering the operation of the plant as a whole. To assist in this difficult balancing act, we developed a membrane filtration operation control support system that effectively couples a membrane fouling model, a pre-treatment model, and a flow distribution model. This support system permits various control conditions to be evaluated in terms of their impact on the total operation of the plant, and thus helps reduce plant operating costs.

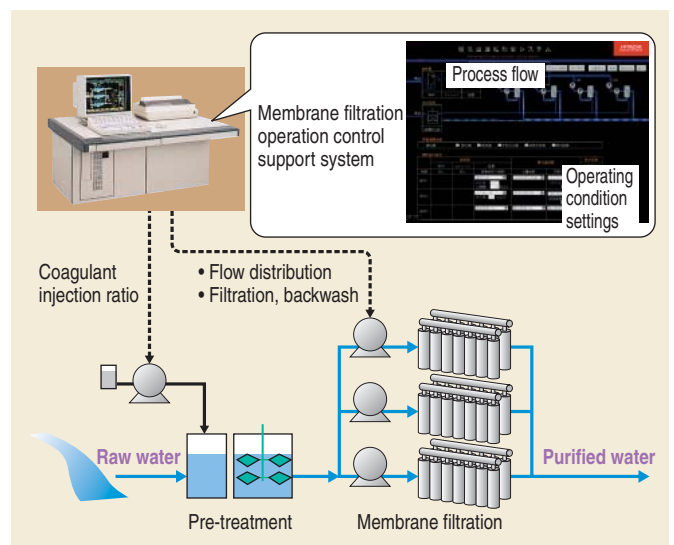

Overview of the membrane filtration operation control support system



Assessing Total Environmental Load Discharge from Sewage Treatment Plants

Fundamentally important issues in sewage treatment are the reduction of greenhouse gas emissions in line with the Kyoto Protocol and the reduction of pollutant discharge into the water in accordance with regulations on water quality and total allowable volume of pollutants, and ways to improve the operation of existing plant facilities and ways to upgrade equipment and systems are being investigated.

With the goal of quantitatively assessing the effects of efforts to reduce the environmental load of sewage treatment plants, we developed a new method for evaluating various environmental load factors—treated water quality, quantities of power, chemical agents, sludge, and greenhouse gas emissions—based on water treatment and sludge treatment process models by inputting the amount of sewage influent, plant equipment conditions, and operating conditions.

[Main features]

(1) The method factors in the sludge cycle between water treatment and sludge treatment systems, hence assesses the total environmental load of discharge from the sewage treatment plant.

(2) An activated sludge model is applied to the water treat-

ment system that enables the amount of sludge discharge to be calculated for the any influent condition of the treatment plant.

(3) The method is especially useful for evaluating environmental load and cost-effectiveness in modifying the operation of existing facilities, and revamping or upgrading plant equipment.

(Announced: October 2005)

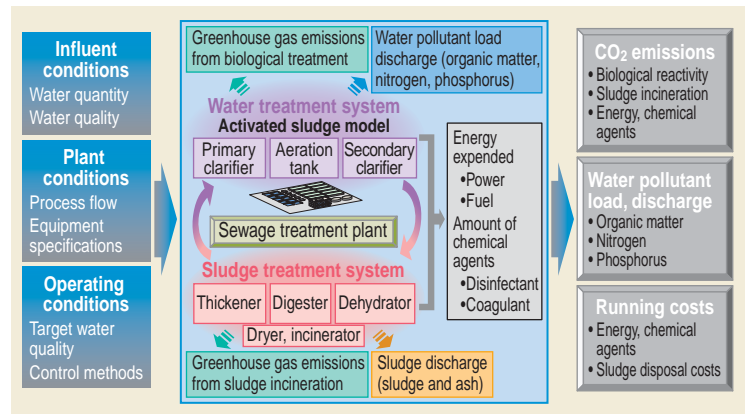

Overview of environmental load assessment at sewage treatment plants



Ministry of Justice Correction Bureau's Mine Rehabilitation Program Center Establishment and Operation Project: Tracking Solution for Inmates

To alleviate overcrowding in Japan's prisons due to worsening crime rates, Japan is in the process of setting up a program called through PFI (private finance initiative) in which inmates are con-

finied to designated security zones. Participating in a consortium led by SECOM Co., Ltd., Hitachi proposed an inmate tracking system that satisfies the stringent requirements of the program, and in April 2005 the Ministry of Justice Correction Bureau approved and ordered the system.

Essentially the system consists of a wireless LAN position information system that tracks and detects the exact position of people with pin-point accuracy called AirLocation and wireless tags that inmates cannot remove. This ensures that inmates can be located within the designated security zone at all times. Position information can be obtained in real time anytime on a monitoring terminal, a solution that not only alleviates the burden of guarding the inmates but also should make the entire operation much more effective and efficient.

(System scheduled for deployment at the Center: April 2007)

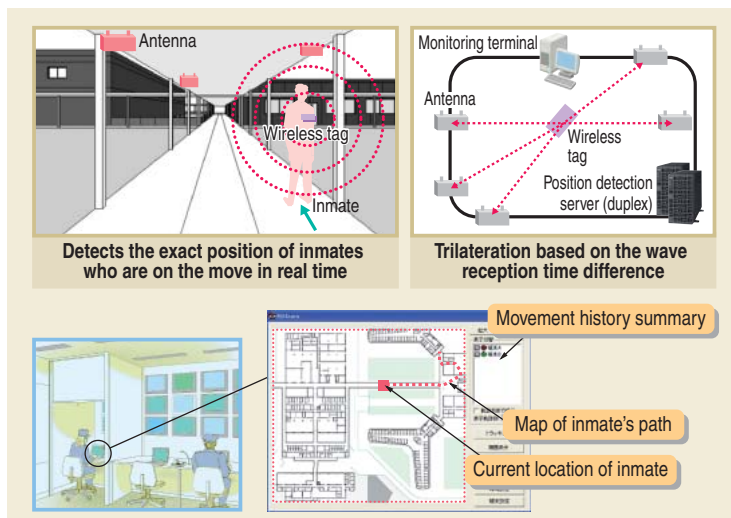

Tracking solution for inmates



Government Information Provisioning System for the City of Ageo, Japan

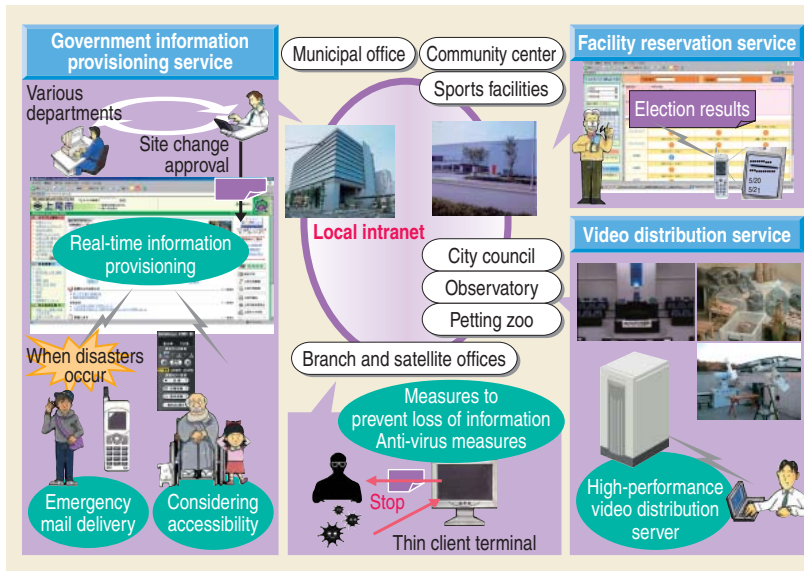

Overview of government information provisioning system for the city of Ageo

A new government Information Provisioning System has been set up in the city of Ageo in Saitama Prefecture that gives the local people access to a wide range of advanced public services in real time.

In this system, site pages can be edited and approved very easily, and the system offers live information with improved visual accessibility. Citizens of Ageo have already expressed strong approval for the system. They find it very useful for reserving public equipment and facilities over their cell phones and for checking on election results. The system also features a high-performance video distribution server that enables the local people to watch meetings and conference proceedings of municipal assembly on their own home PCs or to enjoy live feeds of stargazing through the local observatory telescope or from the local petting zoo. (Delivered: February 2005)



River and Road Disaster Information System for the Oozu River & Road Office, the Ministry of Land, Infrastructure and Transport

Hitachi was commissioned to supply a state-of-the-art information support system to the Oozu River & Road Office—a district that is frequently hard hit by typhoons and torrential rainfall—to help alleviate disasters affecting local roads and diverted rivers.

The system is now installed in the disaster prevention office of a new building recently constructed as a disaster preparedness center for local rivers, roads, and communities. The system features a total of 12 displays that provide a comprehensive overview of weather information (rain volume), river information (sluiceways, dammed basin reservoirs), and road information (road surface conditions, road blockages, and other restrictions) for the entire district superimposed on detailed GIS (geographic information system) maps. The ability to show displays and manipulate strategically placed video surveillance cameras also aids in quick decision-making and developing appropriate disaster countermeasures.

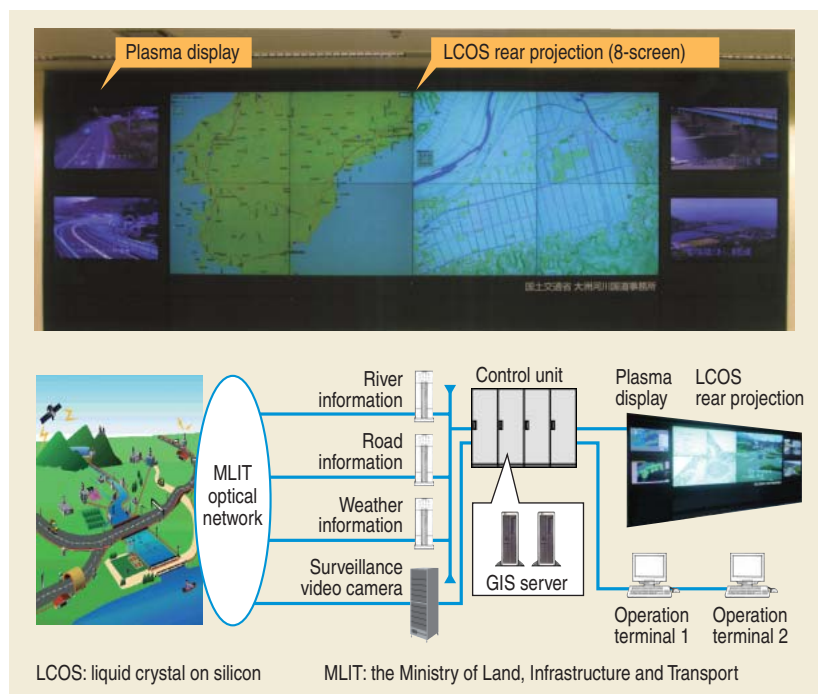

Images superimposed on GIS maps and system configuration



Hazardous Substance Detector Using Mass Spectrometry

Based on a novel counterflow atmospheric-pressure chemical ionization technique, Hitachi has developed a new type of detector that is capable of identifying a wide range of hazardous materials including explosives, illegal narcotics, and dangerous chemical agents. A prototype explosives trace detection system was unveiled in March 2000, and the same basic approach was subsequently used to develop narcotics and chemical agent detection systems.

After the string of coordinated terrorist attacks in 2001, the US Transportation Security Administration (TSA)—an agency well known for its expertise in security matters—procured several thousand of ETD (explosives trace detection) system for deployment in US airports. In 2003, Hitachi's ETD system DS-110E-W was developed and certified by the TSA in May 2005, the first time that a non-American manufacturer of this kind of system has received TSA certification.

We are now stepping up efforts to sell these systems to airports and other critical infrastructure facilities in Japan and elsewhere, while at the same time continuing to refine and improve the performance of the detection systems. Hitachi has applied tandem mass spectrometry technology for the detection of illegal narcotics and chemical agents, a major improvement that will markedly speed up the hazardous material identification process. This will give law

enforcement agencies a valuable tool for quickly and accurately detecting a wide array of dangerous drugs and other hazardous materials.



Explosives trace detection system DS-120E



X-ray Inspection System



X-ray inspection system BIS-X-C6580A

Hitachi's X-ray inspection systems use the penetrating power of X-rays to peer into hand luggage and cargo to detect concealed knives, explosives, and other dangerous items. Any such items hidden in parcels or carry-on bags are immediately detected in the transparent image of the package's content and using a function that differentiates and identifies different materials by color. The system is implemented as a compact box that can be installed in a tight space or conveniently added to standard conveyor type X-ray inspection systems. The system is flexible and can be readily adapted to different uses, different types of sites, and other customer needs.

For critical infrastructure facilities calling for more advanced security screening needs, Hitachi makes a higher end X-ray CT (computerized tomography) explosives inspection system that uses tomography and is capable of measuring the material density and molecular weight of a package's content.



ITS to Assist Pedestrians: Involvement in the Free Mobility Assistance Project

The Japanese population is aging at an unprecedented rate, and by 2015 it is projected that 1 in 4 Japanese will be elderly. This demographic reality is reflected in recent legislation including the “Transportation Accessibility Improvement Law^{*1}” and the “Accessible and Usable Building Law.^{*2}” The ultimate objective is to achieve a “universal society” through the efforts and mutual support of the public sector, the private sector, and society at large. In March 2004, the Ministry of Land, Infrastructure and Transport (MLIT) established the Free Mobility Assistance Project Promotion Committee to consider ways to support freer mobility by the elderly and disabled. Location information could be tied and made available at specific sites by deploying RFID devices (μ-chips or active tags) or other kinds of information devices at various places along streets. This would enable users to obtain information about these locations simply by passing near the RFID location information infrastructure or by using a local site terminal. This infrastructure would provide access to information needed to participate in society and get to work—routing information, information about public transport, and so on—to anyone, anytime, and anywhere.

2005 saw a major trial and standardization of the “Free Mobility Assistance Project” in Kobe, and in 2006 we will begin to see the infrastructure deployment and actual operation of some of the technologies evaluated in this project all across the country.

Working closely with the MLIT, Hitachi has been very much involved in the ITS (intelligent transport system) for pedestrian and has developed a number of RFID-based technologies for the visually impaired and people with other disabilities including a “routing assistance system” and an “audible warning system.” Hitachi also took part in the “Play Trials” in 2004 that were part of the same “Free Mobility Assistance Project” and offered technical assessment of some of the technologies tested in this trial based on Hitachi’s experience and expertise.

Hitachi remains committed to the “Free Mobility Assistance Project” through a wide range of initiatives involving RFID, the wireless LAN position information system AirLocation, deployment of a location information infrastructure that provide site-specific information to users, white canes with embedded RFID readers, directional sensors and other user terminals and peripheral equipment, servers to manage location information and provide information to user terminals. This project is now on the threshold of being extended nationwide, and Hitachi plans to integrate all these related developments into a total solution business.

^{*1} Law for promoting easily accessible public transportation infrastructure of the elderly and disable persons

^{*2} Law for buildings accessible to and usable by the elderly and physically disable persons

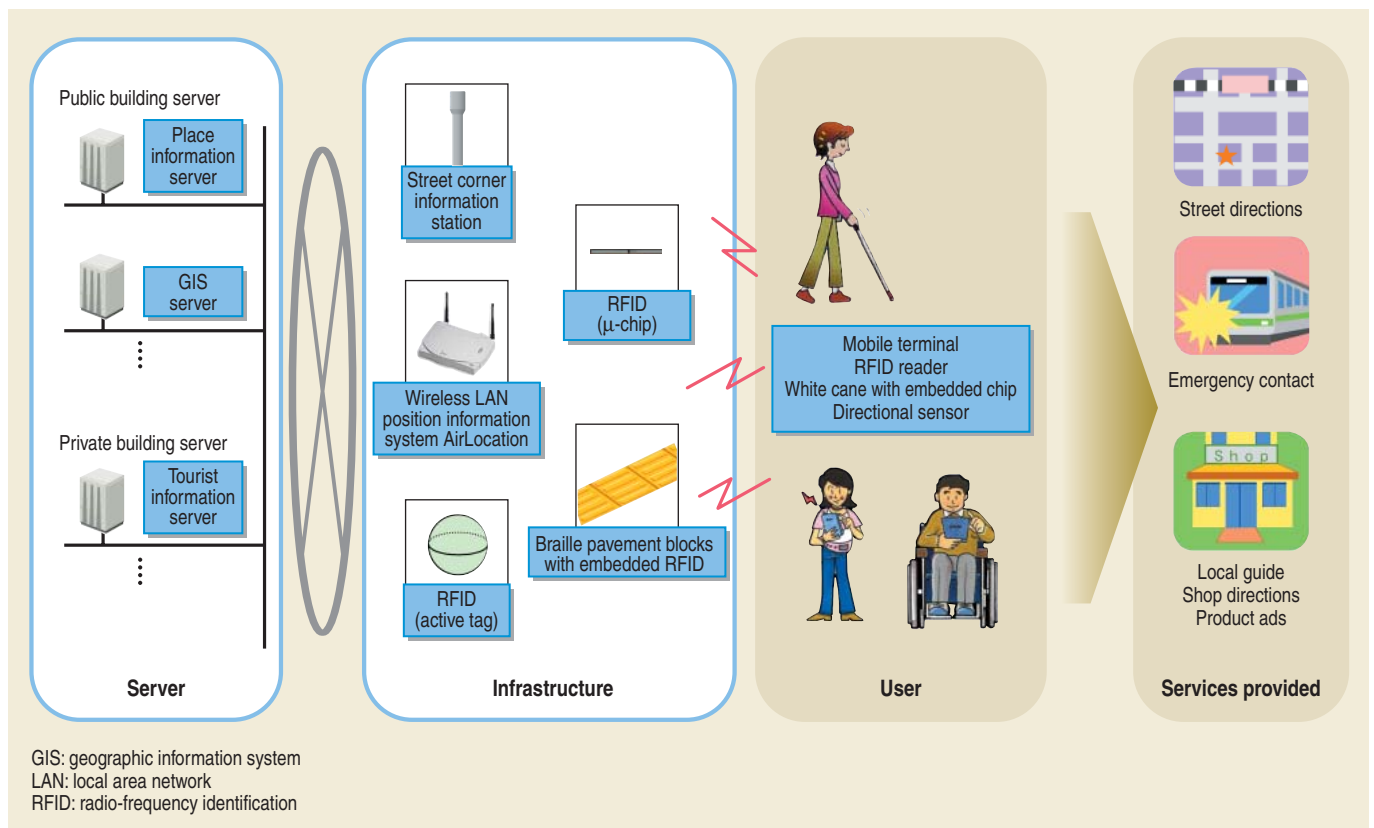

Overview of the free mobility assistance system

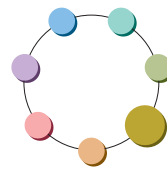

Multifunctional Image Processing Camera

An environment recognition sensor is needed for a drive control system and a drive support system for vehicles, one that recognizes information on the surrounding environment such as traffic lanes, obstacles, the approach of other vehicles, and the weather, among other things.

The functions and circuit composition of an image processing camera that was used as an environment recognition sensor were restructured, and a multifunctional image processing camera was developed. It is faster, cheaper, and smaller than the original. The main product features are various kinds of detection software including lane detection and multitask software executive control management. Product reliability will be checked with an eye towards commercialization. New detection software will be developed.

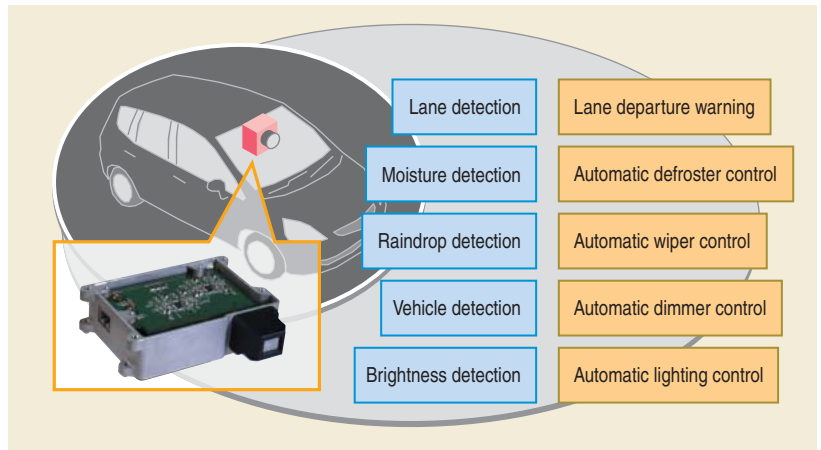

Externals and various functions of multifunctional image processing camera



Embedded Software Technology for Vehicles

Embedded software technology for vehicles—following the continuing tendency to increase added value (environment and safety)—is getting larger in scale and more complex every year. As a result, aiming to improve software quality, Hitachi has restructured embedded processes and software architectures. As regards embedded processes, codes are automatically generated from control models designed by control development, and an embedded process was established. In regards to software architecture, by componentization and hierarchization of software for all functions, independence and interchangeability efficiency are improved. With this technology, it has become possible to promptly provide high-quality software.

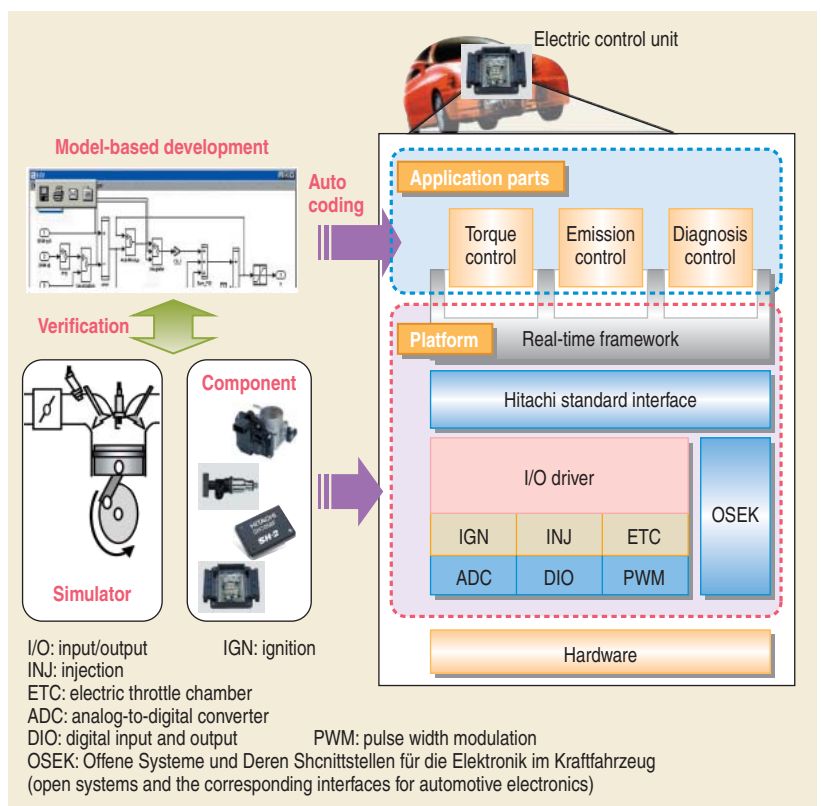

Structure of embedded software



Built-in Control Module for Transmissions

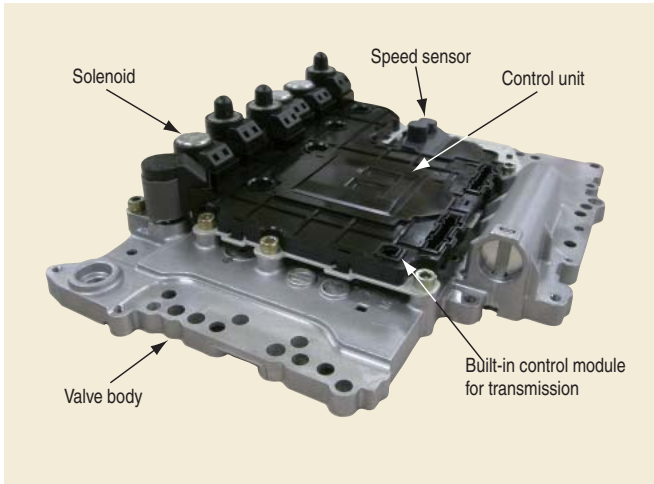

Built-in control module for transmissions

In recent years, automotive parts have increasingly been modularized to improve performance and reduce cost. For transmission systems, automatic transmission control modules composed of integrated mechanical components and electronic parts are appearing on the market. This type of transmission control module is described as built-in.

Hitachi has developed a built-in control module for transmissions that can be used in harsh environments, and is currently mass-producing this module. The electronic parts of the control unit are mounted on a ceramic substrate and subsequently sealed using a transfer mold to withstand the high-temperature oil inside a transmission. Peripheral sensors and actuators have been integrated by using a wiring plate.



Compact Fuel Injection Valve for Vehicle Gasoline Engines

Highly accurate air-fuel ratio control is needed to comply with environmental regulations, which are becoming increasingly stringent. To meet this demand, a compact fuel injection valve has been developed.

The number of parts has been reduced by using piping material

made of deep-drawing stainless material, and the weight has been reduced by optimizing the magnetic circuit. The fuel is atomized using a multi-hole nozzle and fluid analysis.

These technologies reduce exhaust gases such as hydrocarbons.



(a) Compact fuel injection valve



(b) Multi-hole nozzle



(c) Atomization of fuel

Compact fuel injection valve for vehicle gasoline engines



New Type of ABS Developed

A new type of ABS (antilock brake system), which was developed to have increased mountability for vehicles and competitive cost, is among the world's lightest and smallest in terms of onboard projection area (14% less than a competing product) due to its enhanced design.

[Main design factors]

- (1) Cutting time reduced by changing to precision cold forging
- (2) Number of electronic parts reduced by adopting a new custom IC
- (3) Electromagnetic valve size decreased by reviewing functional allocation for each component
- (4) Motor made more compact by using precision stamping technology

Similar specs to those of a high-functionality system will be adopted to improve competitiveness in the future.



New type of low-cost ABS that is among the world's lightest and smallest



Aluminum Rear Caliper with Built-in Parking Brake Function for Toyota Motor Corporation



Aluminum rear caliper for high gas mileage and utility

The weight of the rear caliper integrated into a conventional parking brake was reduced by changing the material of cylinder body from cast iron to aluminum. (18% lighter than a cast-iron product).

[Main features]

- (1) Superior operability of parking brake with ball & ramp mechanism
- (2) Easier vehicle installation due to compact design

The application of this product is expanding to mid-size cars.



Dual Flow Path Shock Absorber

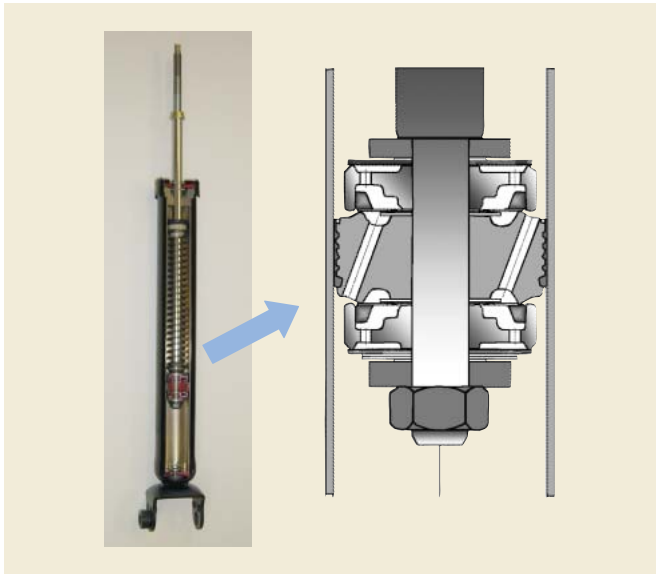

Dual Flow Path Shock Absorber

Electronically controlled suspension systems are becoming more common because they are required to provide exceptional handling and smooth rides in luxury automobiles. However, these systems have limited applications because they increase weight, thus increasing costs and decreasing gas mileage.

We developed an inexpensive valve mechanism that provides exceptional handling and smooth rides by adding a suitable damping property to a conventional shock absorber. This Dual Flow Path Shock Absorber* is used in the Nissan Fuga/Infiniti M35/45, which was released in Sept. 2004, and is expected to be used more widely in the future.

* See "Trademarks" on page 94.



Car Navigation System for Japan, Europe, and North America

Xanavi Informatics Corporation has developed a new car navigation system to be mounted in Nissan vehicles (for Japan, Europe, and North America) and Renault vehicles (for Europe). The system has unique switch and menu designs that suit both companies' brand identities while maintaining a shared concept. Xanavi Informatics Corporation won the Global Innovation Award from Nissan Motor Co., Ltd. for this car navigation system with high-level performance and strong competitiveness that provides functions such as Bluetooth* and traffic information with accurate route guidance and clear visibility. (Xanavi Informatics Corporation)

* See "Trademarks" on page 94.



Navigation system in Nissan Fuga



Next-generation Bullet-train Cars for Central Japan Railway's Tokaido and Sanyo Shinkansen Lines

Four next-generation bullet-train cars are now being tested and evaluated in a 16-car train set operating on the Tokaido and Sanyo Shinkansen Lines. Some of the key features that will be adopted extensively on future railcars include a body tilting system enabling the cars to navigate curves at higher speed, a semi-active vibration control device enabling a smoother, more comfortable ride, and a sleek aluminum double-skin carbody that effectively muffles exterior noise.

Other innovations include a longer tapered nose called the aero double-wing that minimizes micro-pressure waves in tunnel sections, and a new-type of hood that entirely covers the vestibule spaces between cars, thus smoothing the exterior of the train and reducing exterior noise. These enhancements significantly reduce the running resistance of the new bullet-train cars and help the environment by conserving energy.



Next-generation bullet-train cars for the Tokaido and Sanyo Shinkansen lines



Operations Management System for the East Japan Railway Company's Saikyo Line

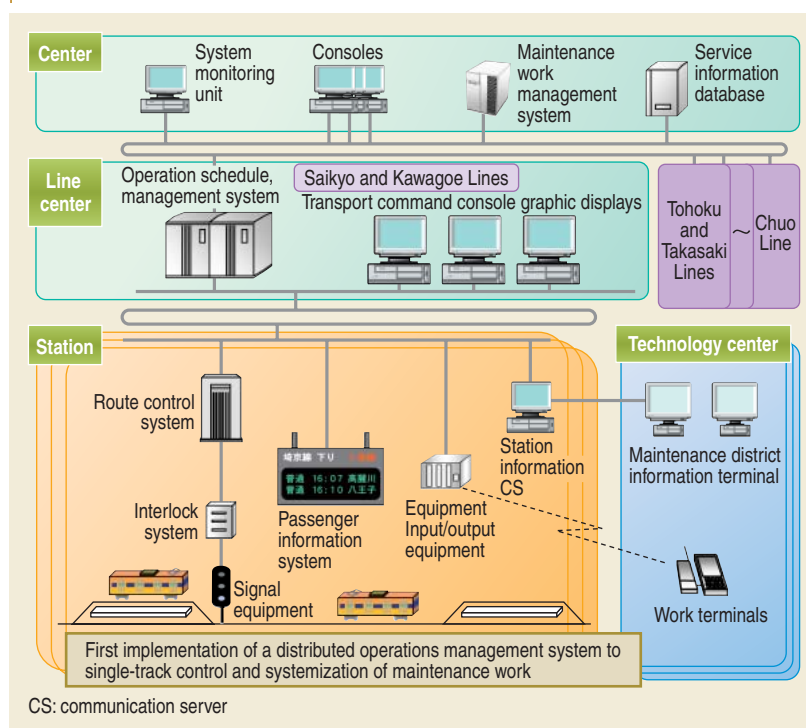

Schematic overview of the ATOS

The ATOS (autonomous decentralized transport operation control system) was deployed on the Saikyo Line of the East Japan Railway Company between Osaki and Komagawa on July 31, 2005.

The system brings a number of new capabilities to the line including improved train route control on a traditionally high-density route, enhanced passenger information services when the trains get ahead or behind schedule, better systemization of maintenance work, and the first implementation of the distributed operations management system to single-track control on the line between Nisshincho and Komagawa. The system also improves operations on sections shared with the Shonan Shinjuku Line and other lines. The ATOS is scheduled for deployment on the Nambu Line in 2006.



Subway Cars of Tokyo Metro Company's Tozai Line

New subway cars employing a unique aluminum double-skin structure are now operating on the Tokyo Metro Co., Ltd's Tozai Line. Based on a radically new assembly method, the cars feature a precision, high-quality aluminum double-skin body constructed by FSW (friction-stir welding), fully self-supporting interior modules, and an integral hollow extruded mounting rail to which the modules are fastened. The assembly is further streamlined by implementing component subsystems as generic modules and curved-surface process machining.

To lessen the environmental impact, a single alloy of aluminum is used in the double-skin structure that facilitates eventual recycling of the decommissioned cars.



New subway cars for Tokyo Metro Company's Tozai Line



Digital ATC System on the Toei Shinjuku Line



(a)



(b)

Signal equipment on the Toei Shinjuku Line of Bureau of Transportation, Tokyo Metropolitan Government was completely upgraded in May 2005 for the first time since the popular line opened to the public in 1978. Adoption of Hitachi's digital ATC (automatic train control) system permits optimum one-step brake control reflecting the performance of each type of train, and this permits reduced travel times between stations. The system also implements a slight easing of brake pressure when brakes are first applied and just before the train comes to stop, which enables a smoother more comfortable ride. Compared to earlier analog systems, the new digital system requires far fewer ground equipment installations and far simpler maintenance procedures. While continuing to promote even closer coordination among ground, onboard, and other relevant equipment, Hitachi remains committed to the development and deployment of more flexible systems enabling faster travel times and reduced train headways.

Digital ATC system on Toei Shinjuku Line Series 10-300 trains: train with onboard digital ATC equipment (a), and ground equipment (b)



Next-generation Elevator Group Control System Using Advanced Forecasting Trajectory Technique

In major cities throughout Asia, more and more high-rise buildings and large-scale multipurpose buildings are being constructed to enhance the utility of the buildings. Elevator group control systems are widely applied to efficiently operate the multiple elevators in such buildings.

Since the 1950s, Hitachi has continuously released advanced elevator group control systems, such as an instantaneous call allocation system in 1972 that informs an allocated car as soon as a new hall call is registered and a floor-attribute control system in 1997 that can change the control setting according to individual floor situations. Furthermore, a system that controls the future trajectories of elevator cars has been developed recently to reduce passenger waiting time in heavy traffic situations.

Conventional group controllers operate elevators based on past and current system situations. Consequently, in heavy traffic conditions, cars are frequently operated in a bunch, and that causes long waiting times. In contrast, the new system forecasts reference trajectories of elevator cars; the control concept is called the AFTT (advanced forecasting trajectory technique), and it aims to operate elevator cars at equal time intervals. As a result, the system can minimize long waiting times by preventing bunched operation of the cars.

The AFTT concept is outlined as follows.

- (1) Reference trajectories of cars are computed that lead the cars toward positions at equal time intervals in the near future.
- (2) Forecasted trajectories of cars are computed if a new hall call occurs.
- (3) The difference between the reference trajectory and the forecasted trajectory is calculated based on the area between the two trajectories.
- (4) A hall call is allocated to the car that minimizes the evaluation value calculated using the above difference.

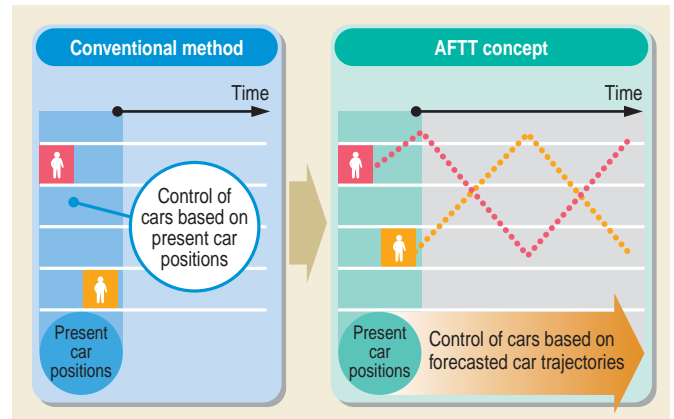

Concept of AFTT

Based on the AFTT concept, an implementation algorithm suitable for a microprocessor has been developed.

Results of simulating the AFTT implementation algorithm show that it performs better than the conventional method in heavy traffic situations. For instance, the ratio of passengers whose waiting time exceeds 60 seconds is 12% less using the AFTT than using the conventional method, and the average waiting time of the AFTT is 10% less. In addition, the trajectories of cars simulated using the AFTT algorithm show that the cars are operated at equal time intervals; on the other hand, trajectories of cars simulated using the conventional method show that the cars are operated in a bunch.

The AFTT-based elevator group control system will provide more efficient and comfortable transport of passengers than conventional systems.

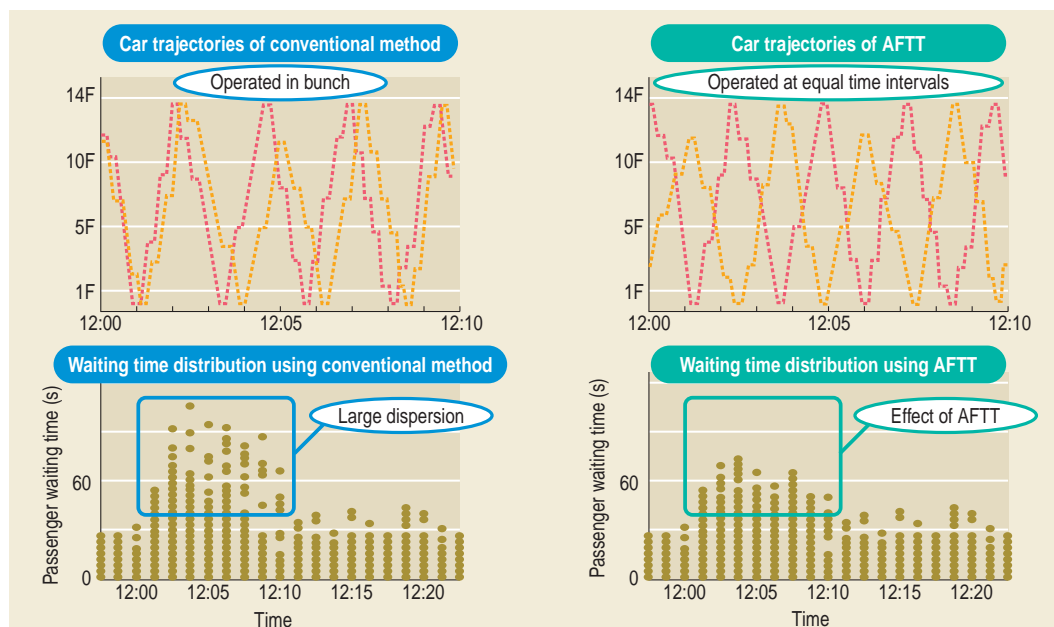

Images of AFTT effect



“IT Condominium” Security System Finds Acceptance in the Chinese Market

Based on a strong favorable response in Japan, the “IT Condominium” security system was made available in China in March 2005 and adopted in THE COSMOS high-rise condominium development in Guangzhou, Guangdong Province.

Security in the common areas of THE COSMOS buildings is significantly improved by synchronizing the resident IC cards with the elevators.

Other services provided by the Hitachi Security Office include reissuing of IC cards and intrusion notification by cell phone so residents feel safe and secure in their homes.



Rendering of THE COSMOS condominium development
(Courtesy of K WORTH GROUP)



22 Sets of Moving Walkways for Central Japan International Airport



Moving walkways

In 2005 February, the terminal building opened at the Central Japan International Airport (Centrair). Hitachi had installed 22 sets of moving walkways including 4 sets of a wide type called S1600 (effective step width: 1,600 mm, effective balustrade width: 1,800 mm), which were the first installed in Japan. Centrair is located on the sea on a causeway over Ise bay and 35 km from central Nagoya. It has features of universal design.

[Main features]

- (1) Wheelchair parallel accessibility
- (2) Audio guidance
- (3) Minimized difference in level at entrance
- (4) Eye-friendly colored-steps
- (5) Braking system preventing falling accidents



New Mini Machine Room Elevator

A mini machine room elevator has been developed for the world market.

[Main features]

(1) Compact mini machine room

The new mini machine room elevator uses a compact gearless machine, which enables dramatically reducing machine room space, and the machine room floor area required is only the size of the hoistway.

(2) Slim door machine

A slim door machine is used that is equipped with an especially slim permanent magnetic motor that does not interfere with the car ceiling, even if a decorated ceiling is used and the car height exceeds the standard.

(3) New interior car and operation panel design

The design of the interior car of the new mini machine room elevator, which includes high-contrast convex character buttons, was developed to facilitate the use of the elevator by the elderly and handicapped.

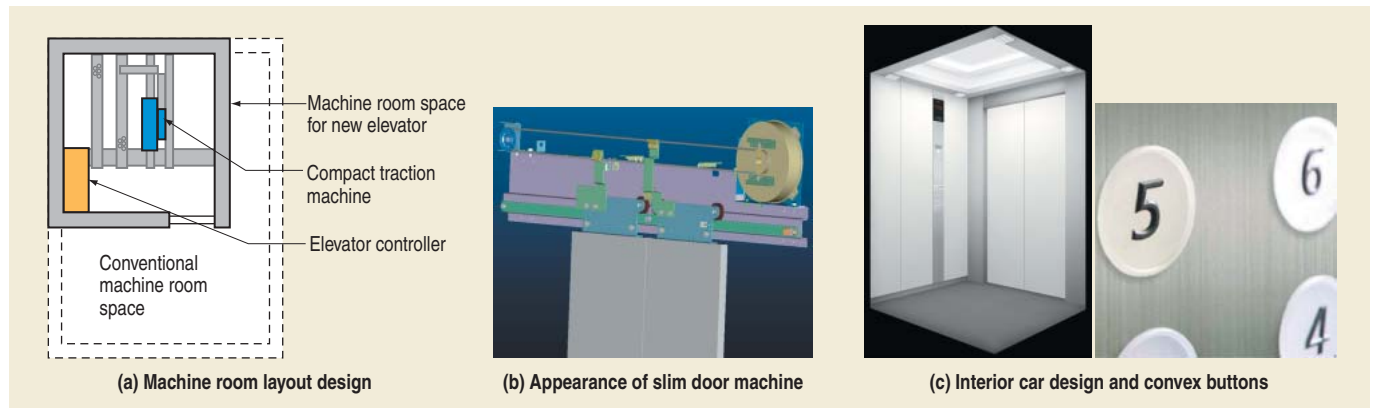

New mini machine room elevator



New Dielectric Etching System: U-8250

Hitachi has now launched U-8250, a new etching system that supports 45-nm node dielectric film processing. Building on the proven capabilities of ECR (electron cyclotron resonance) plasma etching technology, the U-8250 combines excellent microfabrication capabilities with stable operation.

[Main features]

(1) Enhanced plasma and wafer ion implantation control capabilities covering a wide range of dielectric film materials

(2) Improved CoO (cost of ownership) for implementing reactors that support particle-less and lower contamination processing
(Hitachi High-Technologies Corporation)



New dielectric film etching system: U-8250



High-resolution, High-speed Dark-field Wafer-inspection System: IS3000 for 45-nm Node Devices

Equipment and processes on 300-mm wafer fab lines introduce a range of microdefects for a variety of reasons, and these defects can drag down the yield of the fab line. For this reason it is essential to sensitively monitor as many wafers as possible, rapidly identify the causes of defects, and quickly remedy the problems.

Exploiting recent advances in dark-field imaging technology, we have now developed the dark-field wafer inspection system IS3000 combining high resolution with high speed that can be applied to mass production 45-nm node micro-device fab lines.

[Main features]

- (1) A high-resolution dark-field imaging optical system that permits both high resolution together with high speed inspection
 - (2) Supports a high throughput of up to 35 wafers per hour (300-mm wafers).
 - (3) Capable of generating condition setting recipes very quickly
 - (4) A variety of built-in defect analysis capabilities
- (Hitachi High-Technologies Corporation)



High-resolution, high-speed dark-field wafer-inspection system: IS3000



DesignGauge: Semiconductor Pattern Measurement System Based on Design Information

As semiconductor process technology evolves toward smaller features, it becomes increasingly difficult to form submicron patterns in accordance with CAD data. This led to our recent development of DesignGauge, a new measurement system that uses design information to evaluate and compare patterns with CAD data. DesignGauge is software that runs on a PC connected to a metrology SEM (scanning electron microscope) over a network.

[Main features]

- (1) Generates recipes off-line.

(2) Can be operated by remote control.

(3) Uses CAD data to perform a range of measurement functions.

(4) Remeasuring capabilities

Extending these capabilities to compare actual patterns against CAD data, we plan to develop 2-dimensional measurement technology using CAD data to further improve the value-added capabilities of metrology SEM.

(Hitachi High-Technologies Corporation)

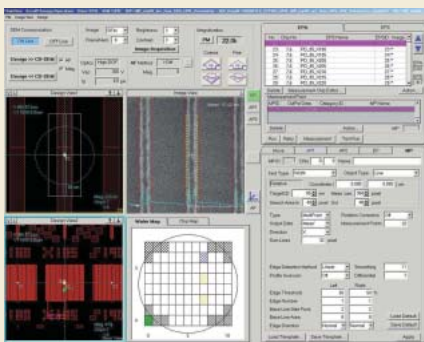

(a)

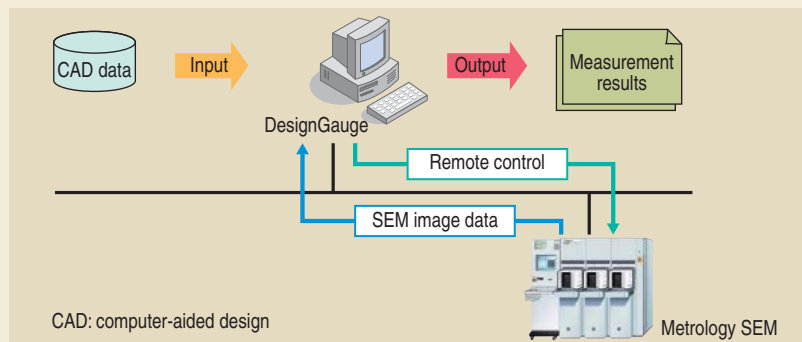

(b)

DesignGauge screen shot (a) and system configuration (b)

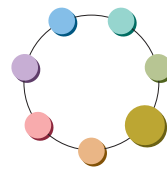

High-sensitivity High-speed SEM Visual Inspection System I-6300 for Next-generation Semiconductor Devices

Hitachi has now developed the visual inspection system I-6300, a high-sensitivity high-speed tool for application to 45-nm node and beyond next-generation semiconductor device fabrication.

As minimum device dimensions decrease and device layers increase, the ability to achieve reasonably fast throughput becomes more problematic for SEM (scanning electron microscope)-based inspection tools that have the sensitivity and potential contrast necessary to resolve such fine features. The I-6300 meets this challenge with an all-new electron-optical system and innovative high-speed image processing to achieve a threefold improvement in throughput compared to the previous visual inspection system, and also provides better detection sensitivity and repeatability.

[Main features]

- (1) Featuring a new electron-optical system and fast image processing technology, the I-6300 offers much better sensitivity and faster visual inspection capabilities.
- (2) A new type of electrode supports improved potential contrast detection sensitivity and repeatability.
- (3) An improved recipe generation support tool makes it easier to

create recipes and reduces the recipe set-up time.
(Hitachi High-Technologies Corporation)



High-sensitivity high-speed SEM visual inspection system: I-6300



Vertical Ultrahigh-temperature Annealer



Vertical ultrahigh-temperature annealer

We have developed a vertical ultrahigh-temperature annealer for batch processing of 300-mm wafers. Developed over a three-year period beginning in 2002, the annealer was one of the advanced semiconductor device process equipment initiative projects supported by NEDO (New Energy and Industrial Technology Development Organization). A number of new technologies emerged in the process of developing the state-of-the-art annealer including a new heating technology that exceeds 1,350°C needed in the SIMOX (separation by implanted oxygen) wafer annealing process, a novel temperature control scheme, technology for reducing crystalline defects, and new technology for reducing metal contamination.

[Main features]

- (1) High throughput: the vertical batch annealer features an automatic wafer transport mechanism that permits processing of up to 75 wafers in a single batch.
 - (2) Precision temperature control: ramping up the temperature is precisely controlled in 1°C increments up to a maximum processing temperature of 1,400°C, well above 1,350°C needed for SIMOX wafer annealing.
 - (3) Precision processing: (a) crystalline defects and slip line propagation in the batch processing is avoided. (b) metal contamination is significantly reduced to less than 5×10^{10} atoms/cm². (c) uniformity of the oxidation layer thickness between batches is reduced to less than 0.2%.
- (Hitachi Kokusai Electric Inc.)



Module Assembly System AL/AB6000 Series for Wide-screen TVs

We have developed a module assembly system supporting automated assembly lines for wide-screen TVs up to 47 inches that integrates the entire sequence from TAB (tape automated bonding) mounting to connection of printed circuit boards and resin coating.

[Main features]

(1) High production level: achieves high-speed line tact of 25 seconds when mounting 14 TABs on two sides of the current most prevalent 32-inch wide-screen panels.

(2) Ensures excellent manufacturing flexibility: (a) various units and buffers can be freely assembled to accommodate any combination of manufacturing line processes and tact times. (b) the AL/AB6000 series can accommodate a wide range of wide-screen panel sizes from 27 inches to 47 inches.

(3) High availability: supports automatic switching of TAB tape, ACF (anisotropic conductive film) tape, and other basic materials, to enable long continuous operation of the line.

(Hitachi High-Technologies Corporation)



Module assembly system AL/AB6000 series for wide-screen TVs



Two-panel, Four-beam UV Laser Drilling Machine



Four-beam UV laser drilling machine, LU-4G212, that drills two panels simultaneously using four beams scanned by 2,000-hole/s galvanometer scanners

Printed wiring board production is growing due to increasing demands for mobile phones, digital cameras, PCs, digital audio-visual equipment, etc. These compact and multi-functional pieces of electronic equipment and components require higher-density wiring with small via-holes. To meet these demands, a four-beam UV (ultraviolet)-laser drilling machine, LU-4G212, was developed.

[Main features]

(1) An optical system was developed that splits a UV laser beam generated by a high-speed, high-power LD (laser diode)-pumped UV pulse laser into four beams and thus processes two panels at a time with two beams. The optical system can produce beams with both top-hat-shaped and Gaussian beam profiles for resin direct micro-via-hole drilling.

(2) An original galvanometer scanner is used that has a design optimized for the rotor dynamics and cooling system operated at a 2,000-hole/s maximum drilling speed. The combination of the four-beam system and the new galvanometer scanner increases drilling productivity by 70% compared to a conventional two-beam system.