

Power Systems



# Information Systems

Solution Services

Software

Hardware

Image and Information Equipment

Network Systems

Communication Devices

Research & Development

Devices / Materials

# HIGHLIGHTS

## Promoting Hitachi-developed Finger Vein Authentication Worldwide

# 2006-2007

In all aspects of life in today's society, there is growing demand for advanced security and personal authentication. For that reason, public attention is being focused on biometrics authentication, which is based on the physical characteristics of individuals. In 1997, Hitachi developed the world's first finger vein authentication technology based on finger vein patterns used as authentication keys. Applied systems based on such technology are now being used in such wide-ranging fields as the technologies for the world's most secure personal authentication.

### Various Weaknesses Identified in Existing Biometrics Authentication Technologies

A biometrics authentication system is now needed to "authenticate" individuals authorized to access an e-transaction or information, or pass through a gate. Why? Because even a system based on the latest IC card technology entails some concerns over the possibility that card holders may lose their cards or passwords, or have them stolen, resulting in fraudulent use by a third party. However, there are certain weaknesses in many biometrics authentication technologies. For example, the accuracy in recognizing "fingerprints" is adversely affected by dirt on the equipment, a scar on a fingertip, high ambient humidity, and other conditions. Another commonly recognized problem is that clearly defined fingerprints cannot be collected from persons working in jobs that require extensive use of fingertips, those with very dry skin, senior citizens, and people having similar conditions. Moreover, since the iris, face, and other physical features represent "information visible from outside," the possibility of such features being photographed or stolen for fraudulent use cannot be denied.

### Advantages of Finger Vein Authentication

Hitachi's authentication technology developed based on "finger veins" is characterized by many features that overcome these weaknesses. First, the target biological information constitutes the "vein pattern inside a finger," which is not identical for any two persons and which cannot be seen from outside. The basic principle involves the use of near-infrared rays to photograph and compare the blood so as to make it virtually impossible to forge a pattern. Aside from fingerprints, this technology is also characterized by the fact that "there are hardly any unregistrable cases." This is the

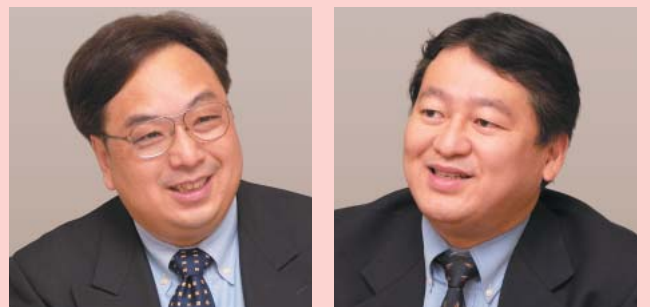

Yasuo Sakai (left), Senior Manager, Finger Vein Global Business Center; Kazunari Kawai (right), Senior Manager, Security Business Promotion Center, Security Systems Div.

same as saying that "there are hardly any cases where any biological information cannot be authenticated." This aspect is very important in a system that ensures personal authentication. Internal testing conducted at Hitachi also revealed that the technology achieves the following precision of authentication: a different-person acceptance rate of one-millionth and a personal rejection rate of a ten-thousandth. The technology has thus proved much more precise than other biometrics authentication technologies.

Authentication equipment is also becoming increasingly compact. Hitachi has also developed a module that can be contained in a notebook PC. The module can be matched to inrolled vein information, thus enabling a person to be authenticated instantaneously. These advantages are combined with the comprehensive expertise of the Hitachi Group, and the technology is already being used in Japan in a wide range of applications, including the ATMs of financial institutions, gate control systems for office buildings and apartment houses, and for PC login.

### Seeking New Business Opportunities with Partners

As applied types of this technology, Hitachi has also developed a grip-type authentication technology and linkage solutions that customize an environment that is personalized for a particular user.

In the future, Hitachi hopes to establish finger vein technology as a global biometric standard spanning North America, Europe, Asia and other markets around the world. Finger vein technology, by enhancing the security of daily transactions such as credit card payments and Internet banking, helps to realize a safer, more reliable, ubiquitous computing society. Through its robust global network, Hitachi hopes to continually provide such value-added solutions worldwide.

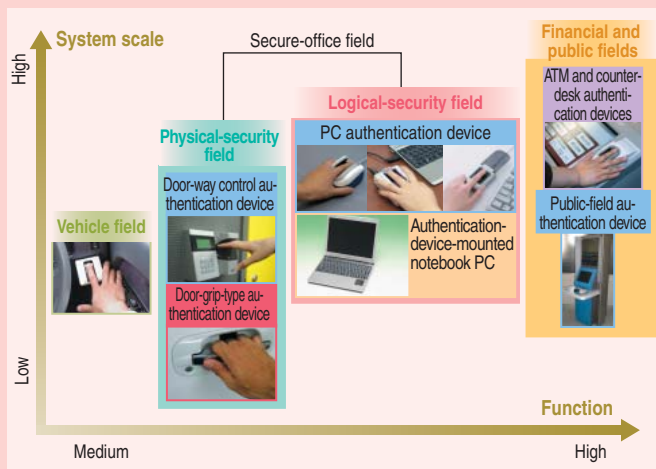

Application fields of finger vein authentication



# Innovative Traceability Solution and RFID Technology

In Japan, recent legislation intended to achieve a safer society has included the Beef Traceability Law, enacted in 2003 to ensure the safety of beef, and the Pharmaceutical Affairs Law, which was revised to improve the safety of medicines. In the field of foods, the trend toward disclosing food history information has expanded in order to assure consumers about the safety of food products. At the same time, in the field of business, enterprises are urgently demanding business reform and efforts to strengthen competitiveness by improving the efficiency of supply chain management. Hitachi's traceability solution is a total business solution that covers everything from consultation to system construction and operation. By using the product technology of the RFID (radio-frequency identification) tags, bar-code, readers, network services, and various applications, our solution records the management history of various items of merchandise from the manufacturing and processing stages to product transport, sales, and recycling. Thus, effectively using the history information collected in an enterprise and disclosing it to the consumer facilitate safer living and more efficient management in the enterprise. As an ASP (application service provider), Hitachi has already introduced an informational sharing service for the meat industry in accordance with the Beef Traceability Law.

RFID is important for traceability as a means of identifying individuals and Hitachi has positively worked on development to offer RFID. Hitachi has already commercialized the "μ-chip" products RFID for the microwave band. The μ-chip is a 0.4-mm square RFID IC chip that uses signals in the range around 2.45 GHz and has a unique 128-bit ROM (read-only memory) ID number with no duplication. This very small chip can be used for a variety of applications including traceability. Commercialization of the "HIBIKI Project" is planned for RFID using the UHF band. The detailed schedule for release to the public will be disclosed later. Beginning in August 2004, Hitachi has been the driving force behind the "HIBIKI Project" under the auspices of Japan's Ministry of Economy, Trade and Industry, and will continue its efforts until July 2006. The goal of the "HIBIKI Project" is to develop the technology needed to produce low-cost inlets (RFID devices) that are interoperable in compliance with international RFID standards. Hitachi will employ the latest RFID technology embodied by the μ-chip and "HIBIKI Project," as well as network services and various applications to propose solutions for each type and field of business in the future.

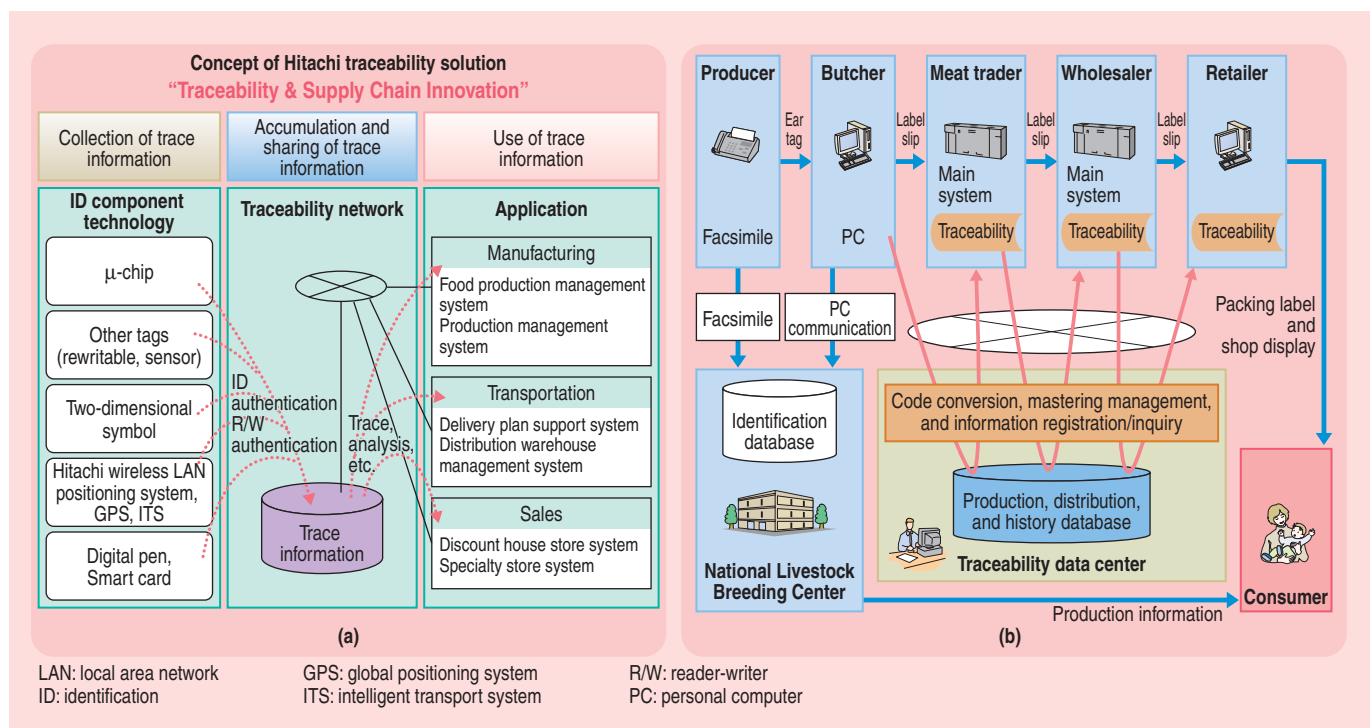

Overview of traceability solution (a) and informational sharing services for the meat industry (b)

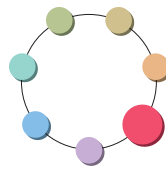

## High Performance Streaming Manager : HDD Solution for Digital AV Equipment

The worldwide proliferation of digital broadcasting and broadband, coupled with expanded 3rd generation mobile infrastructures and closely related broadcasting and communications, has resulted in a drastic change in how we handle content.

Consequently, AV (audio-visual) equipment has changed as well with various kinds of digital AV equipment replacing conventional analog equipment so that we can enjoy the playback, recording, and downloading of hundreds of types of content at the same time.

In terms of content, there is an ongoing trend toward higher HD (high-definition) quality that requires increasingly larger HDD (hard disk drive) capacity year after year.

Thus, digital storage of huge capacity now makes it possible to record desired content while viewing another.

That's why high-performance AV stream control middleware is vital to support stable HDD read/write functions.

High performance streaming manager is middleware that can process video streaming data at high speed. This technology enables much more HD streamings than ever.

Hitachi plans to incorporate this technology into various applications and such devices as audio-visual PCs (personal computers), set-top boxes, and DVD (digital versatile disk) recorders for which there are potential needs for high-speed data processing.

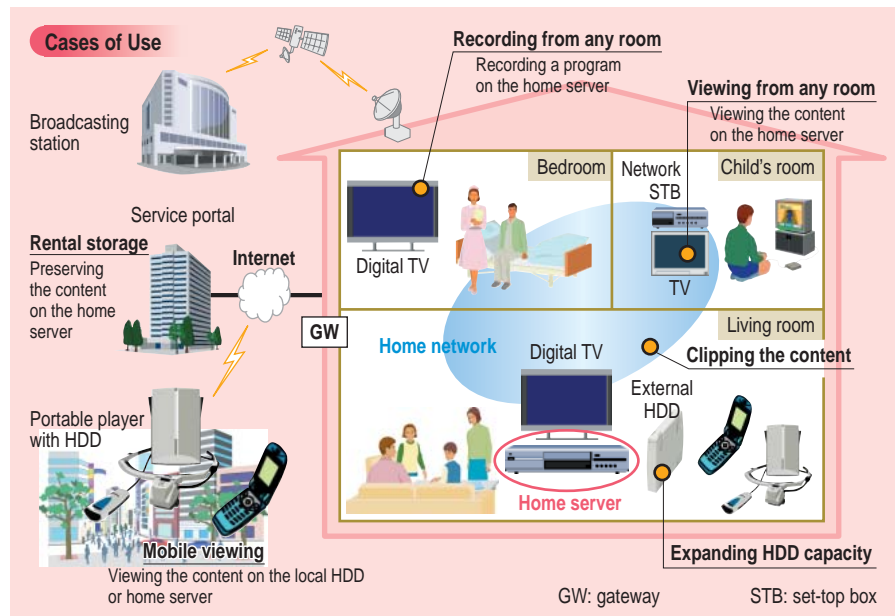

High performance streaming manager: HDD solution for digital AV equipment



## Approach Toward e-Learning in China

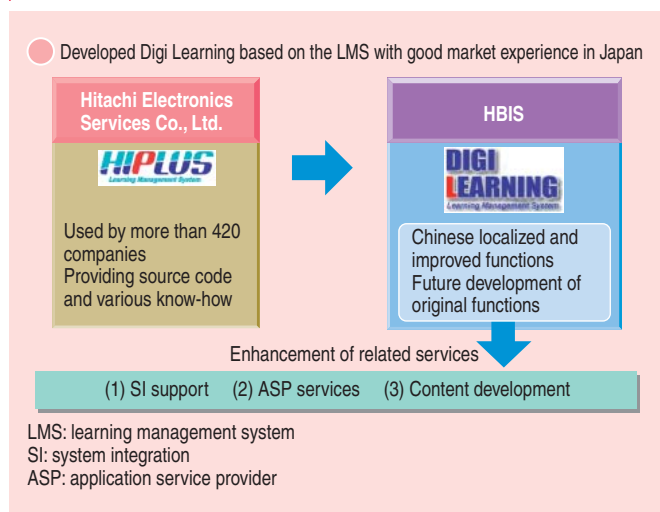

Flow of e-Learning system development for China

In China, there is a high demand from Japanese and local companies for developing human resources in terms of such wide-ranging issues as business etiquette, legal compliance, and management in line with business strategies. IT (information technology) is also being introduced for university education, including e-Learning, in accordance with national policies.

Under these circumstances, HIPLUS (Hitachi performance and learning upgrade support system) which Hitachi Electronics Services Co., Ltd. has already provided to more than 420 companies and universities in Japan, has been further improved and localized in Chinese as Digi Learning (digital learning) produced and provided in China.

HBIS (Hitachi Beijing Tech Information Systems Co., Ltd.) applies the know-how accumulated in Japan to promote the development, support, and structural enhancement of the Chinese version. HBIS also offers reliable local services such as consultation about installation, the development of content, construction of systems, operational assistance, and user support.



## Traffic Simulation for China

HBIS (Hitachi Beijing Tech Information Systems Co., Ltd.) jointly developed a traffic simulator for China called "TrafficVision" with Beijing University of Technology. This is the Chinese localized version of the "Traffic" product that obtained good results in Japan, customized with an additional function of "bicycle/walker/Chinese original left turn lane." This product can simulate the effects on traffic flow caused by improving crossings and constructing a large-scale exhibition site, parking lots, and other facilities. It enables a prompt understanding of related problems and

what needs to be improved in order to examine what actions to take. Moreover, its GUI (graphical user interface) is written in Chinese to address the particular usability of intended users.

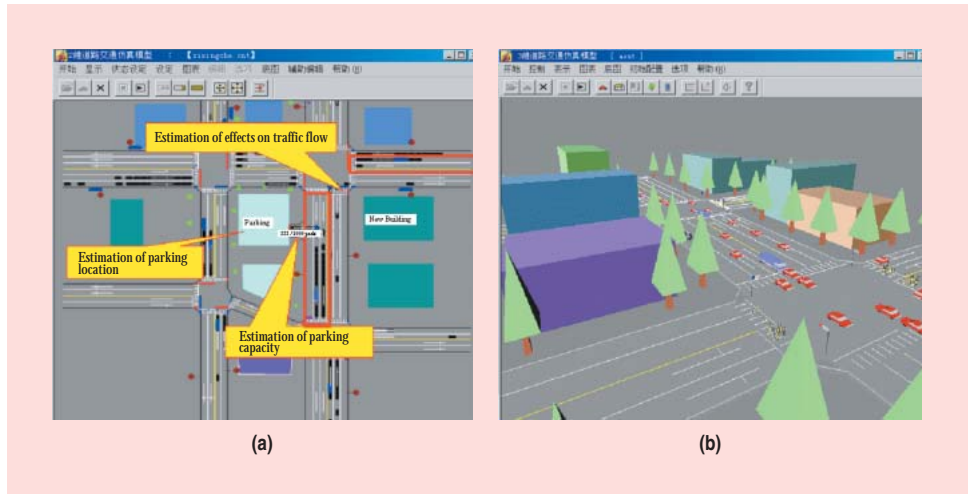

2-dimensional simulation (a) and 3-dimensional simulation (b)



## Launching an IT Solution in China's Logistics Market: An Overview of the Support System for Planning Vehicle Dispatch

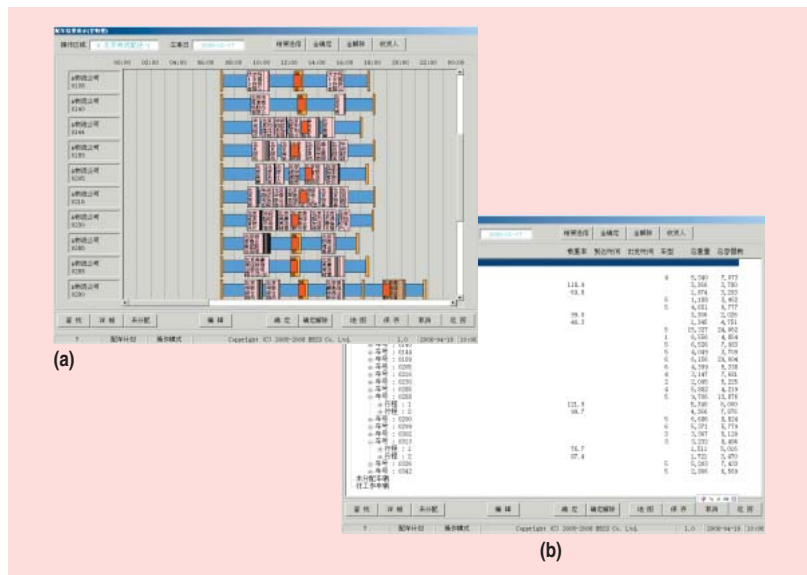

Gantt chart of vehicle dispatch (a) and vehicle dispatch list (b)

China's logistics market is rapidly expanding. After researching the logistics IT market, we discovered a high demand in the TMS (transportation management system) market and consequently commercialized a support system for planning vehicle dispatch through HBIS (Hitachi Beijing Tech Information Systems Co., Ltd.) in March 2006. The system that we developed this time is based on the support system for planning vehicle dispatch that has made considerable achievements in Japan and the Republic of Korea. This product offers an IT solution that integrates the Hitachi Group's BPR (business process re-engineering) know-how into existing functions for reducing dispatch costs.

Since releasing the support system for planning vehicle dispatch, we have received many inquiries about the product from Chinese and Japanese logistics companies. In the future, we plan to enhance its strategic functions including the simulation of eliminating and consolidating logistics bases.

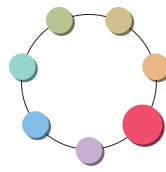

# Hysteresis Signature Library for Guaranteeing the Long-term Credibility of Digital Documents

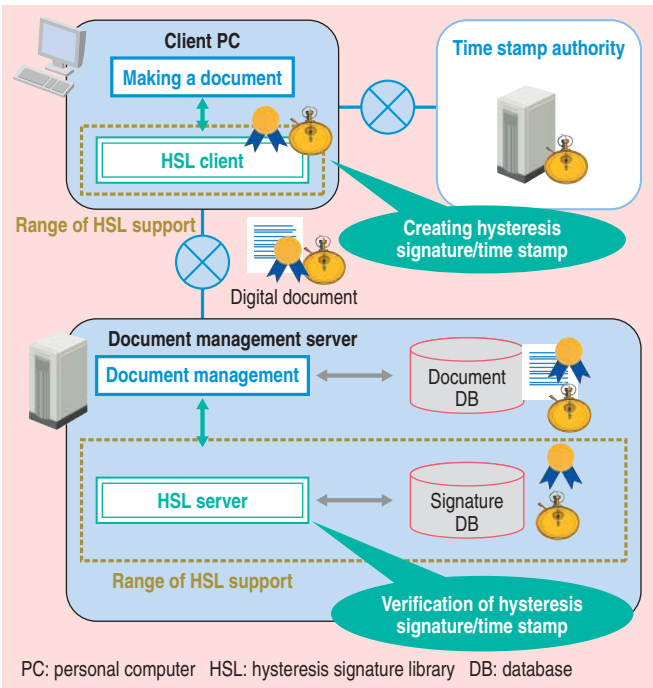

System composition of hysteresis signature library

As computers become more popular, various applications for government services are being filed online. Thus, guaranteeing the authenticity of digital documents is indispensable in filing applications online because it is easy to falsify digital documents without leaving any traces. Moreover, integrity, confidentiality, and readability are generally considered requirements for guaranteeing the authenticity of digital documents.

Hitachi's hysteresis signature library assures the long-term integrity of digital documents by creating hysteresis signatures, which are digital signatures with a time stamp.

Document management applications can assure the integrity of documents by integrating the hysteresis signature library.

Hysteresis signatures are verified by using a chain structure between each signature. As a result, periodic time-stamping for extending the validity of digital signatures is not needed.

Therefore, a user can reduce the cost of guaranteeing the long-term credibility of digital documents.



# Digital Pen Solution with New Print on Demand Functionality

Digital Pen is equipment that digitizes stroke data written on specifically printed paper. The Digital Pen Solution provided by Hitachi enables the automatic transfer of stroke data to an appropriate system. The efficiency and usability of our Digital Pen Solution has been proven in various fields of business. For instance, we have provided this solution for medical facilities, manufacturers, and such logistical fields as vegetable and fish markets. This time, we have introduced new types of functionalities called Print on Demand Software and a Form Creation Tool, in addition to the basic functions.

[Main features]

- (1) The dedicated paper for Digital Pen can be printed on a color laser printer, so that one may obtain necessary copies of paper from our office, instead of having to order it from a printing company.
- (2) Key data in the application system can be inserted when printing paper, thereby enabling instant linkage between the written data and the database.
- (3) If one makes a mistake when writing on paper, the mistake can be easily corrected or simply deleted by using double lines to cross it out.
- (4) One can easily create and define the format of paper on a client

PC (personal computer).

With these new benefits, we believe that our Digital Pen Solution can be applied to even wider areas of business.

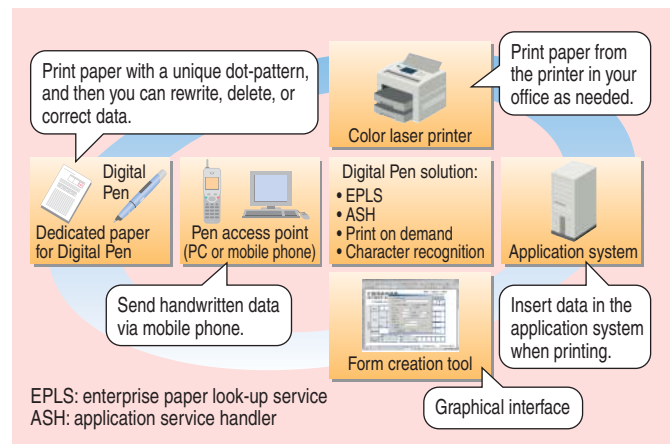

Overview of Digital Pen Solution



## Expanding the Eco&PLM Solution Business with Collaboration

New environmental regulations such as the EU's RoHS (restriction of hazardous substances) directive have recently been enacted throughout the world. Manufacturers are now required to precisely

ly and continuously manage the chemical substances used in their products. This required management applies to all stages of the product lifecycle.

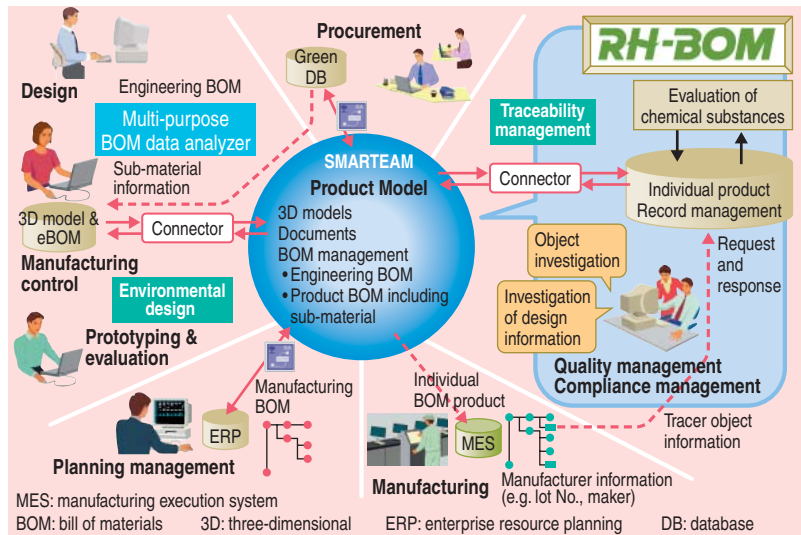

Multi-purpose BOM data analyzer and RH-BOM collaboration with SMARTEAM

In 2005, Hitachi implemented its new chemical substances traceability system along the complex supply chain of Hitachi's RAID system (one of Hitachi's global products) worldwide through the Eco&PLM (product lifecycle management) project. This project made it clear that PLM and chemical substances management solutions are both indispensable and effective. In March 2006, Hitachi began applying the solutions outside Hitachi, in collaboration with Dassault Systemes, an influential PLM solution vendor. Hitachi's multi-purpose BOM data analyzer and RH-BOM solutions will be linked to the SMARTEAM\* PLM solution of Dassault Systemes. Linkage with the multi-purpose BOM data analyzer enables the real-time evaluation of hazardous chemical substances in products at the design stage, and linkage with RH-BOM enables accurate traceability functionality throughout the product lifecycle. The synergistic effect of both distinctive features can innovate a user's business.

\* See "Trademarks" on page 94.



## HITPHAMS Entering a New Stage

The international harmonization in drug manufacturing brought many regulations and laws to pharmaceutical industries. Many pharmaceutical companies face difficulties in meeting the requirements, and seek the opportunity to expand their business by complying with applicable regulations.

Hitachi launched its latest version of HITPHAMS (Hitachi Pharmaceutical Plant Management System) that complies with new regulations. HITPHAMS is a packaged system dedicated to pharmaceutical and related business practices consistent with CGMP (current good manufacturing practices) guidelines.

Moreover, since HITPHAMS must support different languages in the global marketplace, the latest version of HITPHAMS provides multilingual support (requiring a dictionary).

[Main features of HITPHAMS package]

- (1) Fewer human-errors through a step-by-step process based on SOP (standard operation procedure)
- (2) Paperless capability in fields of manufacturing and compliance with FDA (Food and Drug Administration) Part 11
- (3) User configurable print forms and SOP definitions
- (4) Easy collaboration with manufacturing

Hitachi's HITPHAMS solution offers one of the best ways to solve problems and expand the pharmaceutical business.

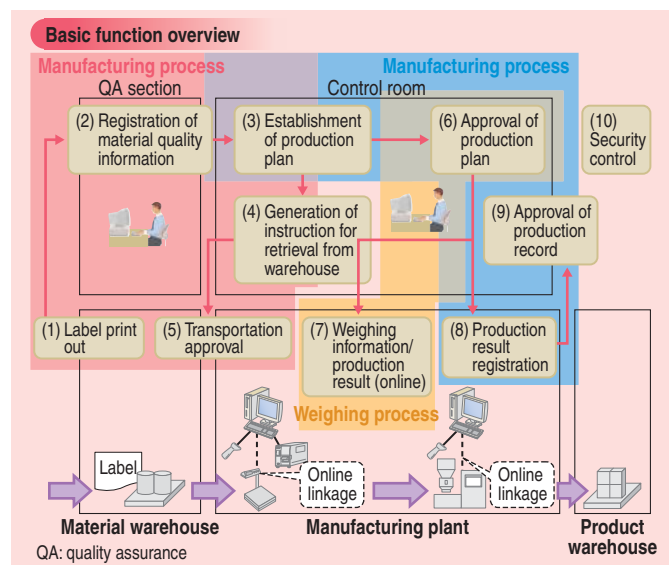

Overview of HITPHAMS

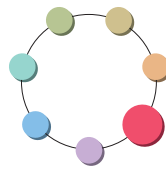

## Linkage Package for MES/ERP Manufacturing Results

Since most manufacturers have introduced the ERP (enterprise resource planning) package, and as a core system the MES (manufacturing execution system) becomes increasingly interlinked, the equipment (process) manufacturers whose data about manufacturing results may contain measurement errors are beginning to realize the vital challenge of resolving numerical contradictions in closing inventory data.

In that context, we have developed a linkage package for manufacturing results between a core system and a manufacturing execution system. The package is designed to formulate and automate the adjustment of information about incoming and outgoing goods between departments, and resolve conflicting information about the distribution of products (both of which take a few days) for alleviating the burden on the personnel concerned and shortening the time required for closing data about incoming and outgoing goods. In addition, another feature is

visual master maintenance using the ERP master.

In the future, we intend to extend these functions from the linkage of manufacturing results to the control of unit requirements and accommodate the interfacing needs of various ERP versions, thus aiming to enhance the linkage of a wider range of a core system and a manufacturing execution system.

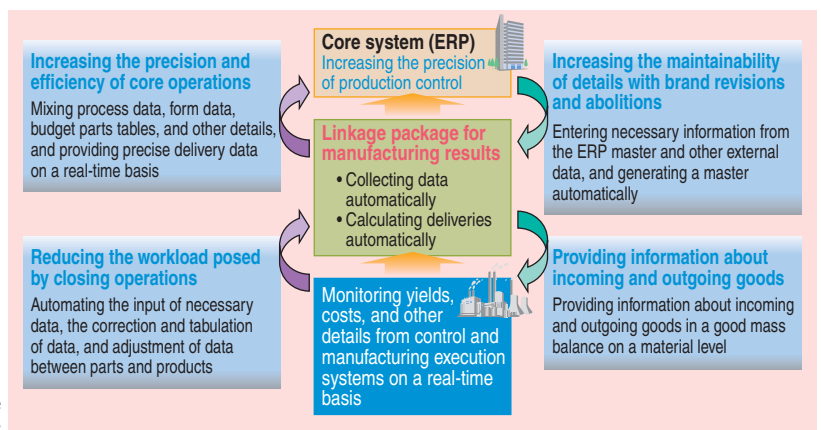

Position and purpose of linkage package for MES/ERP manufacturing results



## Integrated Monitoring and Control System for Controlling the Supply of City Gas

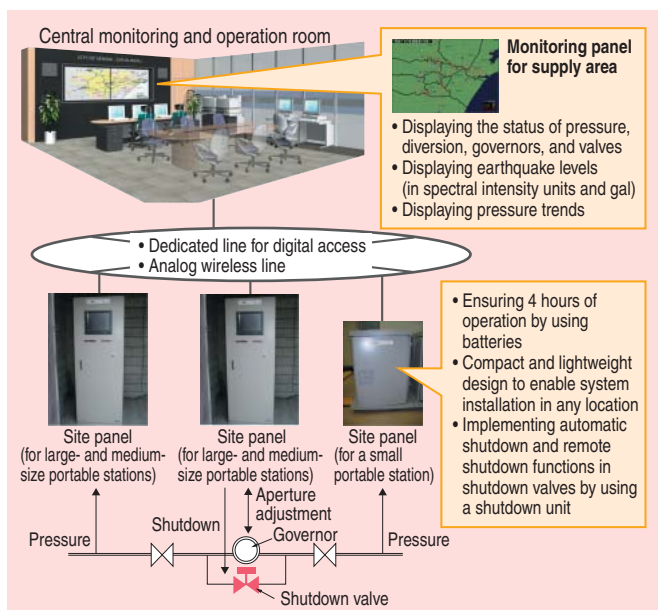

Example of system layout for the integrated monitoring and control system for controlling the supply of city gas

Ensuring a stable supply and providing security are the most important tasks of personnel in charge of controlling the supply of city gas. As the city gas network expands, systems capable of coping with large earthquakes are considered essential. In August 2005, we released the "System for the integral monitoring and control of supply equipment," which not only has supply control functions capable of remotely monitoring and controlling the pressures and flow rates of gas flowing in existing city gas piping from the center, but also functions to collect earthquake data from the entire supply area, monitor the magnitude of a specific earthquake, and remotely shut down the governors. This system helps operators estimate the extent of damage and decide whether to continue or stop supplying gas in order to minimize damage. The system also discloses various data collected on a real-time basis to outside establishments and makes it available to the public, thus helping to realize a society well prepared to cope with disasters. Efforts are also under way to speed up wide-range radio transmission, beef up security, and reinforce wireless technology, and reduce the size and weight of portable site panels, thus further segmenting the range of monitoring and control. Work is thus in progress every day to step up the functions for disaster damage prevention and speed up and stabilize infrastructural advances.



## Job Management Partner 1 Version 8: Autonomous Operation Management Realized from a Business Standpoint

While the business environment tends to change rapidly, information systems must be closely harmonized with the business environment and adapted to accommodate changes in the business environment for ensuring stable company growth.

The latest edition of Hitachi's Job Management Partner 1 provides cutting-edge autonomous operation management technology that enables one to automate sophisticated operations according to conditional changes to information systems in response to changes in the business environment.

When conditional changes are made to information systems, related enhancements allow one to automate a series of operations such as checking several statuses, such as server load, and taking the most appropriate measures for problems based on this checking by predefining a series of operation rules. This automaton of sophisticated operations based on these stored operation rules lets one extend the application of automated operation management, automate the most appropriate operation management processes, promptly take corrective measures to solve problems, and improve management quality. Moreover, while deciding which measures to

take, one can manually select the most appropriate ones based on the checking of several system statuses in addition to being able to take the most appropriate measures automatically. As a result, one can take the most appropriate measures based on a given business situation. By providing the most suitable operation management for the entire system from a business standpoint, Hitachi's Job Management Partner 1 supports stable company growth.

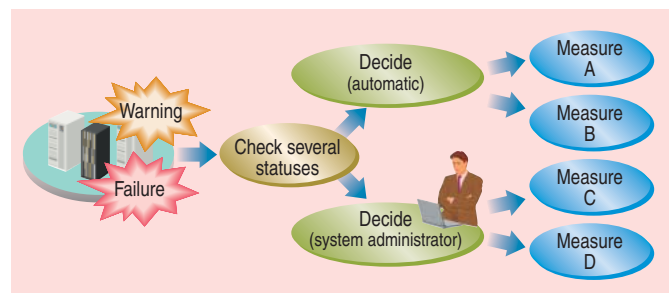

Automation of a series of operations



## A Universal Application Platform—Hitachi Application Server Version 7: Realizing SOA with Proven System Integration Know-how

Businesses today face a dynamically changing market coupled with higher than ever customer expectations, tougher competition, and increasing cost pressure. Implementing an IT (information technology) system that can quickly adapt to changes in the business

environment is becoming a matter of critical importance in order to maintain continuous growth in business.

In response to customer needs for building a resilient IT infrastructure based on SOA (service-oriented architecture), Hitachi is releasing a universal application platform called "Hitachi Application Server Version 7\*."

Version 7 implements a flexible ESB (enterprise service bus) and a standards-based BPEL (business process execution language) engine. "Business process integration" visualizes business processes, thus making it easy for a business to quickly adapt to changes in the business process, as well as reducing the development cost of application integration to about one-third of what it used to be. "Information integration" allows transparent and integrated access of heterogeneous data dispersed throughout an enterprise without having to construct a new database or change management operations.

In developing Version 7, Hitachi incorporated system integration know-how that it has accumulated over many years. As a result, the product provides reliability and availability features that are both unique and highly valuable to businesses.

\* The Hitachi application server is called "Cosminexus" in Japan.

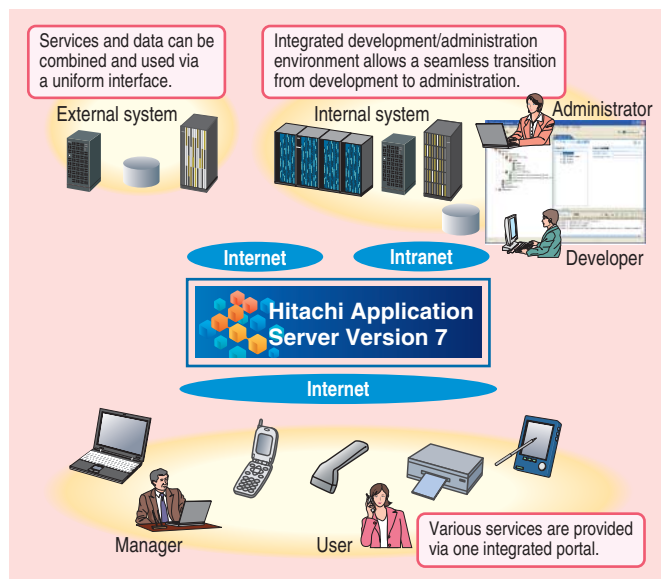

One universal application platform to cover everything from the ubiquitous devices to the enterprise information systems

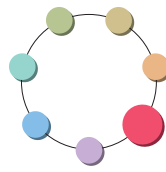

# Information Fusion Technology for Activating Enterprise Information

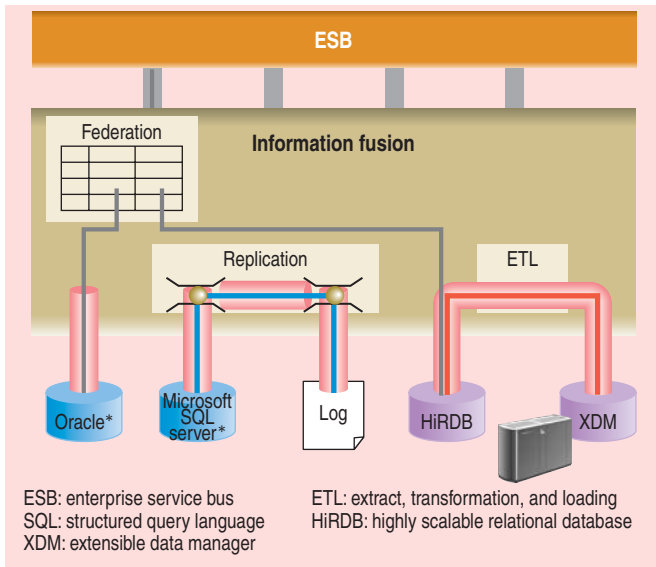

Information fusion technology

\* See "Trademarks" on page 94.

The IF-P (information fusion platform) is an essential building block for SOA (service-oriented architecture), and provides the foundation for a strategic information integration framework. IF-P capabilities allow applications to access diverse sources—distributed and integrated, structured and unstructured—by managing data distribution, replication, and synchronization across applications and databases.

IF-P provides the following key data management features:

### (1) Federation

Building a unified view table across several individual database systems as if they were a single resource, thus allowing applications to access (retrieve/update) distributed and heterogeneous data.

### (2) Replication

Creating a consistent replica database with minimal impact on active applications by applying database log files.

### (3) ETL

Retrieving, updating, transforming, and loading information from diverse distributed sources.



# Small Footprint and High-performance Data Management Software for Embedded Systems

"HiRDB Embedded Database Entier" is a sophisticated relational database management system for embedded applications. Boasting high performance, but small enough to fit into consumer devices, this system provides familiar SQL (structured query language) data management plus advanced search functionality. Moreover, it simplifies device data management, thus accelerating the time to market and enabling engineering to focus on delivering competitive features.

### [Main features]

#### (1) High performance, small footprint

It outperforms databases many times its size, and provides enterprise-class data management for embedded systems. The tiny footprint is configurable from a few tens to a few hundred kilobyte depending on the functionality used in an application.

#### (2) Data integrity

Its reliable file system protects data against unexpected power failure. Data integrity is thus guaranteed.

#### (3) Advanced search

As well as standard SQL, it provides advanced text and spatial search functionality to specify the needs of various devices, including consumer electronics and control systems.

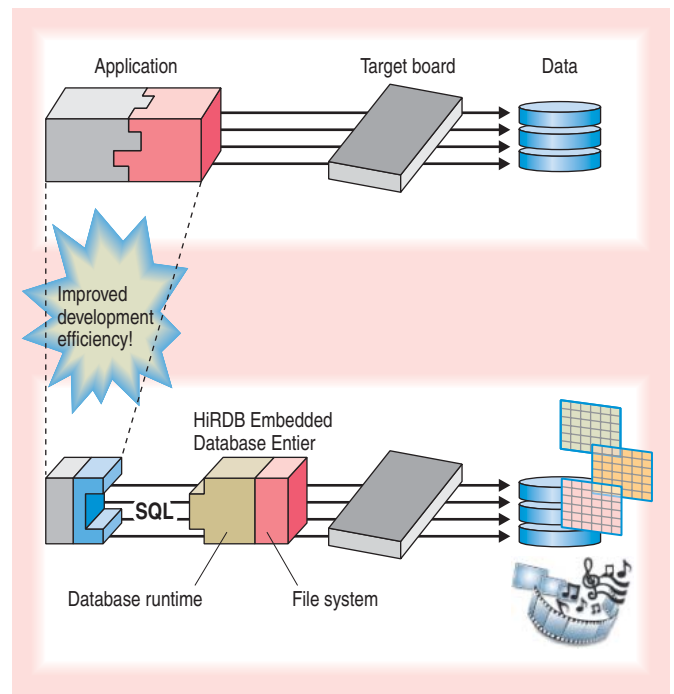

Improvement of development efficiency



## A Highly Scalable and Performance-oriented Blade Server Platform—“Enterprise Blade System”

Hitachi believes that an IT (information technology) system should automatically adapt to the requirements of radically changing business environments. A product that focuses on the vital core needs of our customers' business should: cross the framework boundaries of existing servers, storage, and network products; eliminate burdens such as construction, implementation, and maintenance that accompany complicated large-scale systems; and offer the diversity and flexibility of an open system. These qualities are found in Hitachi's new integrated service platform, the Enterprise Blade System.

The Enterprise Blade System is a server, storage, and network-integrated product that inherits its core expertise from our line of highly reliable mainframe platforms, bound together by our management software solutions. Hitachi's platform will adapt to and accommodate our customers' ever-changing business environments, focusing on the core of their business and ROI (return on investment).

Together with the growing needs of your business, the Enterprise Blade System can expand server, storage, and network hardware resources, while supporting configuration changes with our management middleware solutions. Since resources are modularized, the initial configurations for deployment and future expansion can be implemented quickly and at minimal cost. Thanks to the integrated network platform, network configuration changes and network expansion can be supported through our management software. Storage is shared entirely within the system, so that existing resources can easily be used for expansion and support of any new business. A database layer is also integrated for greater flexibility

in mission-critical data.

The Enterprise Blade System can also provide easy and customer-friendly operation management in the enterprise area. In terms of improved performance, it supports up to 8-way SMP (symmetric multiprocessor) on the IPF (Itanium\* processor family) server module. The Xeon\* processor-based 2-way and 4-way modules constitute a complimentary hardware line, offering the same system integration for server farms and clustered systems. Transaction recovery with a standby server and high-speed switchover for hot standby ensure system reliability and availability on either processor architecture.

Its excellent performance and many available features make the Enterprise Blade System ideally suited for any environment, ranging from small department office systems to large back-end ones.

The Enterprise Blade System adds value to the customer's business by considering and accommodating unexpected business changes and growth.

The Enterprise Blade System was originally introduced to the Japanese market in 2004 under the “BladeSymphony” brand. Since then, the product offering was expanded to the North American market last November, and to the Korean market in January 2006.

More than 100 systems have been installed as alternatives to mainframes and UNIX\* systems, hosting mission-critical applications for a variety of customers in multiple industries with emphasis on finance and telecommunications.

\* See “Trademarks” on page 94.

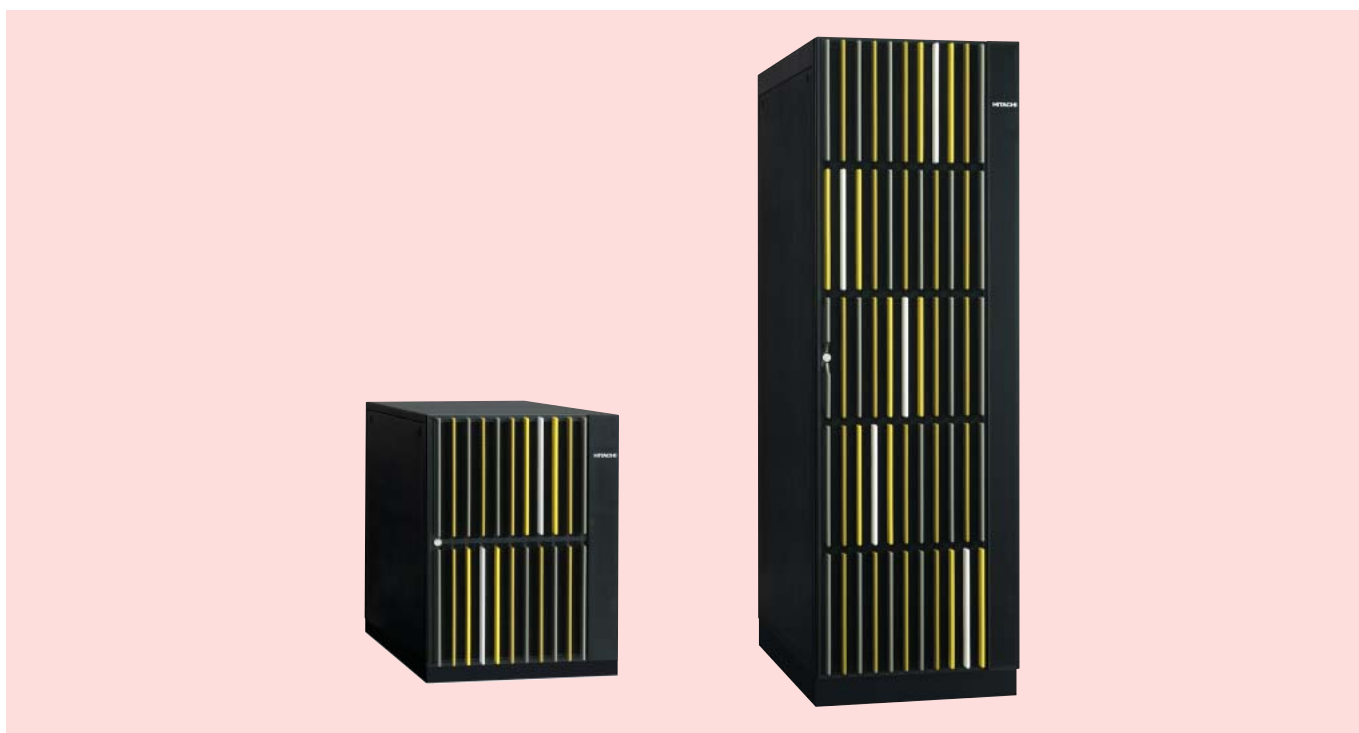

Enterprise Blade System (right) and entry-level model (left)

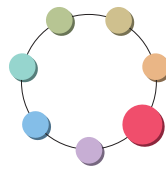

## Blade-type Personal Computer—Client Blade System

The Client Blade System is a blade-type personal computer, with enhanced high performance and ultra-high density. Depending on the ultra-high density design, 14 personal computers can be put in a 3-U (unit: 1 U=44.45 mm) height enclosures. As a result, more than one hundred personal computers can be consolidated in a 38-U height rack cabinet. Moreover, the manage-

ment of these personal computers can be unified, so as to reduce TCO (total cost of ownership).

In addition, using a thin client (especially of Hitachi's security PC series) as a terminal of the Client Blade System ensures both high performance and high stability, thus eliminating the risk of secret information being leaked from a company.



Blade type personal computer—Client Blade System



## IA Server: HA8000 Series

The IA (Intel architecture) server HA8000 Series offers enhanced high performance and reliability.

The HA8000/110W is a 1-U (44.45 mm) height midrange-class server. It constitutes the core of this series, and achieves high density and high performance. It saves space for implementing servers for supporting a system having a large number of servers, such as at the Internet data center.

[Technical highlights]

- (1) Support for up to two server-processors, with scalable system performance
- (2) 1-U height and up to 900-Gbyte (SCSI) or 600-Gbyte (SCSI RAID5) capacity
- (3) Support for online-spare-memory feature to avoid system down even

in case of memory module failure

- (4) Up to 16-Gbyte ECC DDR266 registered DIMM (dual in-line memory module) directly addressable as main memory
- (5) One hot-plug PCI-express slot and one PCI (peripheral component interface) slot
- (6) Redundant and hot-plug fans and power supply



HA8000/110W model: high-performance and reliability 1-U compact server



## Enterprise Server Series for Powerful Support of Mission-Critical Work

This enterprise server series offers the high reliability and high availability needed for mission-critical systems. The series uses Hitachi's proprietary programs that users already have and makes new business possible.

The high-end/mid-range server in this server series uses Hitachi's Virtual-Storage Operating System 3 (which provides the main support for mission-critical work), featuring 64-bit architecture based on CMOS (complementary metal-oxide semiconductor) processors. This server can expand the scale of on-line operations, accelerate batch processing, and process large amounts of data at high speed. Moreover, this server offers high reliability, security, and database/storage management functions required for backend servers, such as disaster recovery, data encryption, and the acquisition of access logs in a database.

The other server in this series uses the POWER\* processor as an instruction processor. This server supports Hitachi's proprietary operating systems (Virtual-Storage Operating Systems 1 and K) based on Hitachi's emulation technology. Moreover,

Hitachi provides a hybrid system in which one of Hitachi's proprietary operating systems and the AIX\* work together using partitioning technology.

\* See "Trademarks" on page 94.

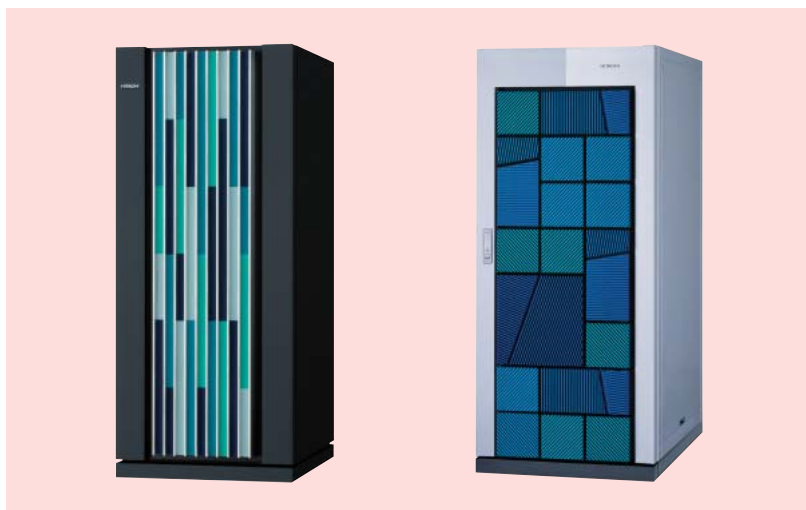

Enterprise server with 64-bit architecture based on CMOS processors (left) and enterprise server with the POWER processor (right)



## New Super Technical Server

To meet the growing need to perform large-scale scientific and technical calculations, Hitachi has added model K1 with enhanced computational power to its super technical server series. This new

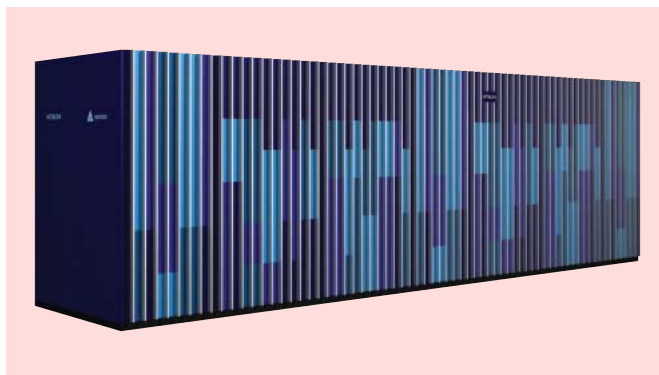

Super technical server model K1 (32-node configuration)

model offers outstanding system balance by combining high performance processors with a high-speed inter-node network.

Model K1 employs the latest POWER5+\* (2.1-GHz) processor. Each processing node is a symmetric multiple processor consisting of 16 POWER5+ processors. Model K1 can be configured using 4 to 512 nodes according to user requirements. The maximum configuration affords world-class processing capability of 68.8 TFLOPS (tera floating-point operations per second). Compared to its model J1 predecessor, model K1 offers effective performance that has been improved by more than 20%.

In addition to its capabilities for fluid analysis, crash analysis, and weather forecasting, model K1 can also deliver high performance in new fields of application, such as nanotechnology, biotechnology, and environmental simulation. It can also be applied to grid computing for scientific and technical calculations.

\* See "Trademarks" on page 94.

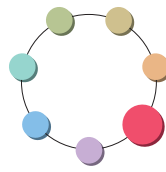

## Hitachi's Disk Array Subsystem Series: Meets the Demands of Customers of Every Size with Optimized Storage Scalability and Performance

Along with advances being made in IT (information technology) these days, the amount of data continues to grow and the applications in IT infrastructures are becoming increasingly diverse and complex. Consequently, many companies are now facing difficulties in managing the growing amounts of data. Moreover, companies must also comply with data retention regulations that mandate the long-term retention of electronic data. Given this trend, customers must manage data effectively, while making efforts to reduce cost at the same time. In response to this IT trend, Hitachi provides customers of every size with a wide-ranging disk array subsystem series.

Hitachi's enterprise-class storage platform, which realizes the first-ever disk array controller-based virtualization, allows customers to consolidate multiple, externally connected storage devices. Moreover, it provides logical partitioning capability by offering a virtual storage device dedicated to each server, and universal replication capability through new-generation, asynchronous remote copying technology.

Moving to the midrange market, Hitachi recently released its top model in the midrange class that offers the highest scalability and performance in Hitachi's midrange series, thus succeeding the existing renowned model. This new model is characterized by the following enhanced functions: Multiple interfaces [4-Gbit/s FC (fibre channel)/NAS (network attached storage)/iSCSI (Internet small computer system interface)] on the front-end, supporting up to two interfaces per device so that customers can choose the optimal interface to meet their application requirements. An enhanced cache partitioning function, which has been expanded up to 32

partitions, lets users customize storage performance based on application by fine-tuning resources. Moreover, enhancement includes an asynchronous remote copy function in addition to the already diverse range of functions, thus providing customers with disaster recovery/backup, data retention management, and other capabilities. For small- to medium-size businesses, or for systems requiring less scalability, Hitachi offers a line of lower midrange models to accommodate their requirements. As a result, Hitachi provides customers with a wider-ranging midrange series lineup.

As for the low-end series models, customers can use them as on-line and near-line backup or for archiving data onto a large-capacity SATA (serial advanced technology attachment) drive that offers Hitachi's original, highly reliable functions. Moreover, given the flexible modular structures, users can extend their systems from small- to maximum-scale configurations, thus optimizing their IT investment.

Hitachi also leverages such advanced storage technologies into NAS systems ranging from high-end class storage to low-end storage for meeting diverse customer needs by providing solutions according to each customer's application and system scale. Since NAS allows customers to leverage their existing IT infrastructures, they can manage multiple storage systems with minimum IT investment.

Therefore, Hitachi's disk array subsystem series that offers optimized scalability and performance also provides a wide range of capabilities. Hitachi continues to meet the demands of companies of every size by helping improve their business value and minimize their storage TCO (total cost of ownership).

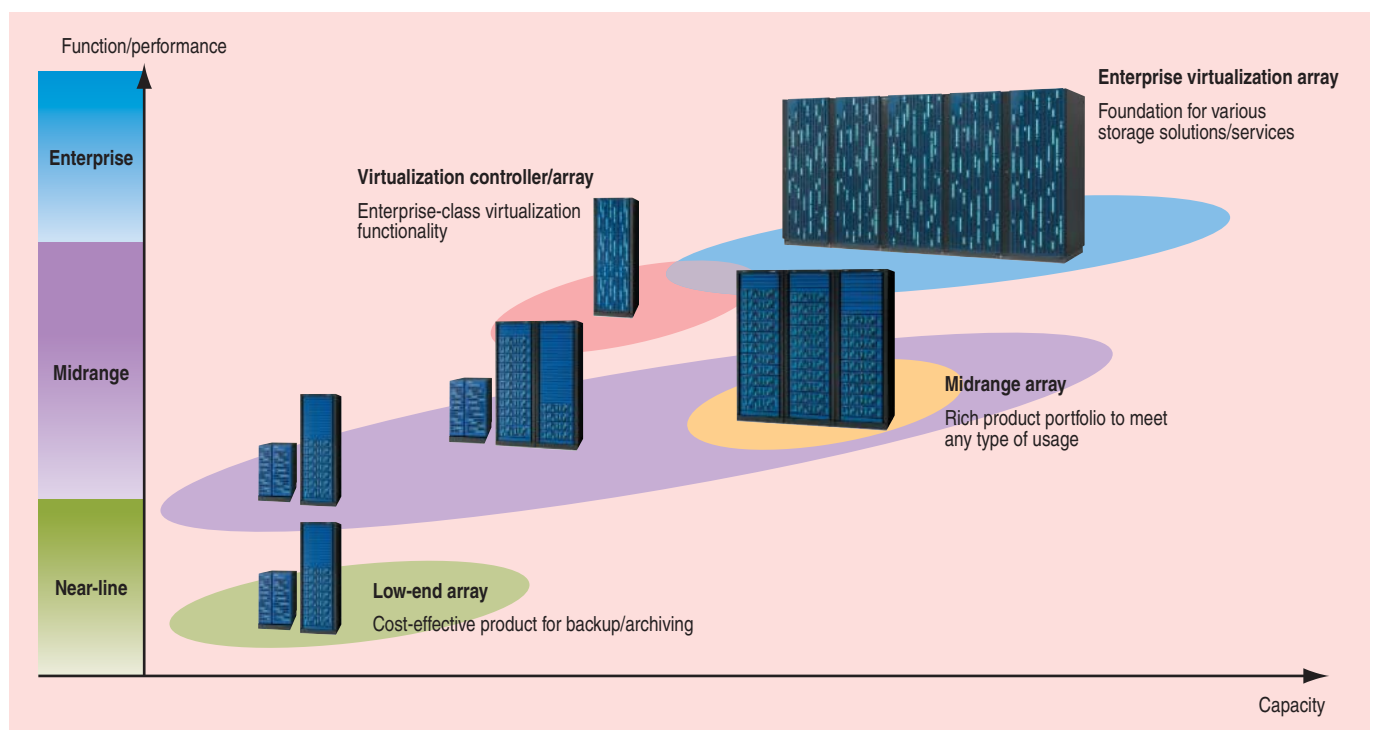

Hitachi's disk array subsystem series lineup with the newly released top model in the midrange class



# Hitachi HiCommand Suite Enhanced to Simplify Storage Management, Business Continuity

Hitachi's customers have enjoyed the benefits of consolidating storage into highly available, intelligent storage systems shared over storage area networks. Yet that consolidation has not eliminated the challenges facing large organizations from the rapid ongoing growth in storage capacity and increasingly complex infrastructures. These challenges include:

- (1) Managing increasing storage capacity with the same number of IT engineers or less;
- (2) Efficiently matching the requirements of applications to a tier of storage with the appropriate performance, availability, functionality, and cost;
- (3) Complying with legal requirements regarding long-term, secure data retention;
- (4) Training staff on the latest wide range of device-specific management tools and tactical storage resource management tools; and
- (5) Building a flexible storage infrastructure to more quickly respond to new business opportunities.

The rapidly maturing Hitachi HiCommand Storage Management Suite provides a full range of capabilities for coping with these challenges by greatly simplifying the management of heterogeneous storage environments in the following ways:

## (1) Application management

HiCommand delivers application-to-spindle capacity and performance management for the most common messaging, databases, and file server platforms, including Oracle, Microsoft SQL Server, Sybase\*, Microsoft Exchange Server\*, and Windows\* and UNIX file servers.

## (2) Operations management

HiCommand offers fast, efficient solutions that automate complicated manual administrative tasks such as installing Host Bus Adapters, managing World Wide Names, identifying and upgrading out-of-date firmware, deleting unnecessary or redundant files from file servers, finding new capacity possible for any application, providing that new capacity, and diagnosing "it's slow" help desk calls.

## (3) Data management

HiCommand provides a complete toolkit to move application data between tiers of storage. The unique HiCommand Tiered Storage Manager simplifies the management of classes of data and moves data between tiers without disrupting applications. Tiered Storage Manager, combined with the powerful, controller-based virtualization capabilities of the Hitachi TagmaStore Universal Storage Platform and Network Storage Controller, enables storage administrators to move data to the most appropriate existing tier of storage, thereby reducing costs.

In addition to Tiered Storage Manager, HiCommand includes several modules designed to improve application and data availability, including HiCommand Global Link Availability Manager, introduced with HiCommand Suite Version 5.0. HiCommand Backup Services Manager manages and simplifies all aspects of backup and restore functions, and provides predictive analysis of tape consumption needs, while boosting successful backup completion rates for greater data protection. HiCommand Replication Monitor simplifies the configuration and administration of Hitachi's best-of-breed replication software used by many large financial institutions and other businesses. HiCommand Dynamic Link Manager provides robust path-failover and load-balancing capabilities to ensure 24/7 data access. For organizations overwhelmed by the challenges of simultaneously managing multiple servers and multi-path storage environments, such as Dynamic Link Manager, HiCommand Global Link Availability Manager provides simple integrated single-point management and reporting capabilities to improve administrator efficiency and minimize configuration errors. Through ongoing improvements, the HiCommand Suite delivers quantifiable benefits by simplifying management, ensuring availability and performance, and lowering the total cost of providing Application Optimized Storage solutions for the critical applications that drive business processes.

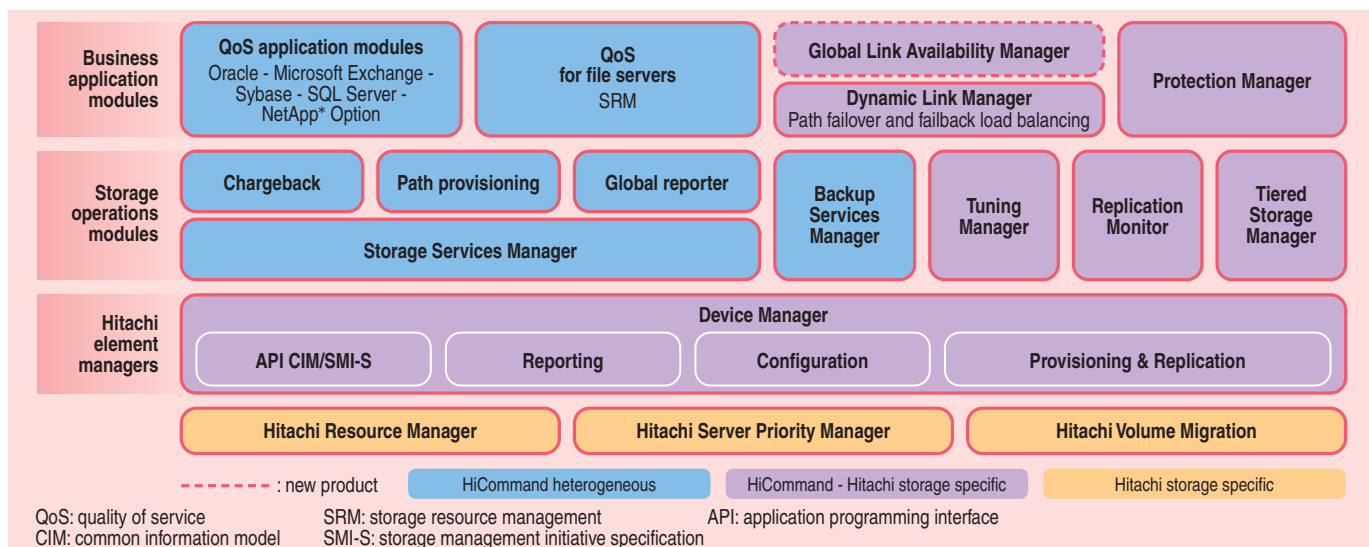

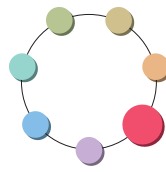

## Security PCs that Provide Information Security— Desktops/Notebooks

An environment where people can access information from anywhere is indispensable for helping business people to speed up their business activities and meet customer needs in a society with ubiquitous computing. Conversely, efforts to prevent leaks of information due to the theft or loss of a PC (personal computer) and other incidents are becoming an important requirement for corporations in order to maintain public confidence. This has prompted us to develop and market the desktop/notebook of security PCs without a hard disc drive.

The security PCs are designed to accumulate information on the desks of individual employees at the office or on a server, and remotely access data on the screen using a keyboard and mouse. User authentication is restricted by using a special-purpose authentication device and password entry. Consequently, information leaks can be avoided even if a security PC is lost or stolen. Moreover, since there is no FDD (floppy disc drive) or optical disc

drive and access to the interface and/or card slot is limited, information cannot be taken out. In addition, unified information and management not only increase security but also help reduce operating costs.

We have marketed the following two models as the product lineup.

### (1) B5 mobile notebook

This thin-profile, lightweight model (weighing about 1.3 kg) comes equipped with LAN (local area network)/wireless LAN capabilities and a built-in modem, is easy to carry around, and provides easy access. It is ideally suited for preventing information leakage for mobile purposes.

### (2) Stationary desktop

This model features a space-saving design that occupies only a small footprint on the desktop. This high cost-performance model can transmit gigabits of data on 1000BASE-T.

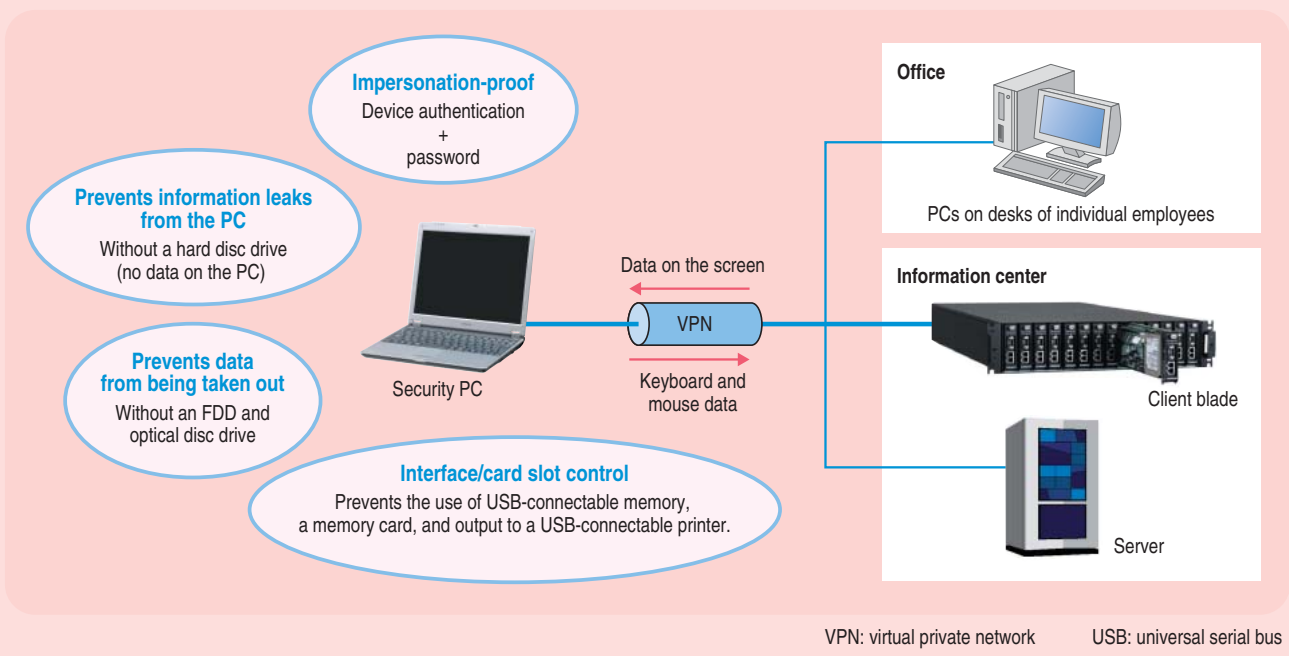

Security PCs that provide information security



## High-resolution SXGA+ LCD Projector: CP-SX1350

- (1) CP-SX1350 supports native 1,400 × 1,050 pixels. This high resolution is good for displaying CAD (computer-aided design) data, detailed graphs, and charts.
- (2) High brightness of 3,500 lm
- (3) Rich optional lenses ready
- (4) Control and monitoring capability via a network

\* See "Trademarks" on page 94.



High-resolution SXGA+\* LCD projector: CP-SX1350



## Total Secure Solutions

In addition to providing convenience and enhancing productivity, building reliable and safe systems has become an important challenge facing corporations in recent years. For that reason, Hitachi, Ltd. has proposed total solutions:

[Major systems]

- (1) Security PCs (personal computers) (disk-free) and other cyber security systems that prevent illegal access from a network, and

equipment from being stolen or taken out

- (2) Physical security system based on video monitoring and finger vein authentication to prevent equipment and information from being taken out

- (3) Video and information distribution, teleconferencing, remote monitoring, and other systems for enhancing convenience

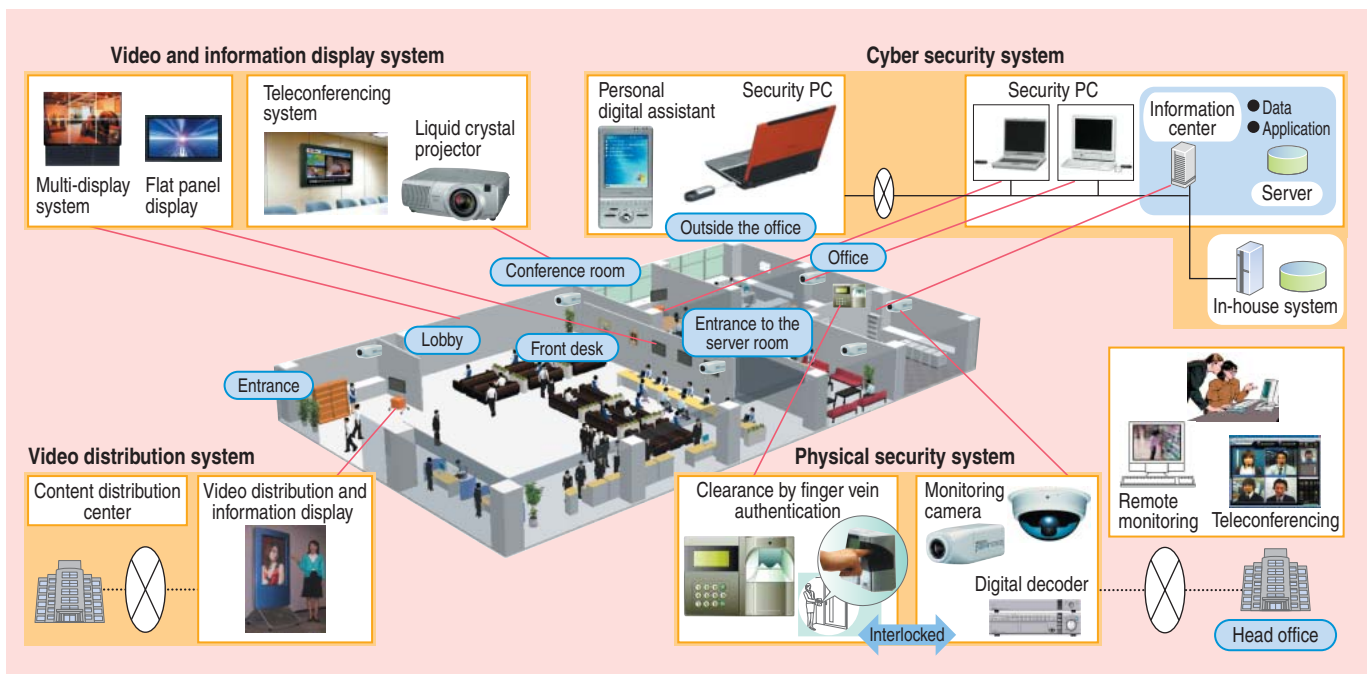

Total secure solutions

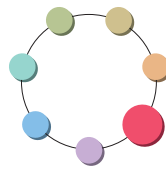

## GbE-PON Optical Access Unit: AMN1500

This unit is a GbE (gigabit Ethernet\*) system compliant with IEEE802.3ah (Institute of Electrical and Electronics Engineers 802.3) that is connected to individual households by optical fiber to achieve very fast transmission at 1.25 Gbit/s. The unit incorporates the PON (passive optical network) system that connects station equipment OLT and domestic equipment ONU by an optical splitter (with up to 32 branches). The unit also comes equipped with QoS (quality of service) control capability to provide data, sound, video, and various other services.

\* See "Trademarks" on page 94.

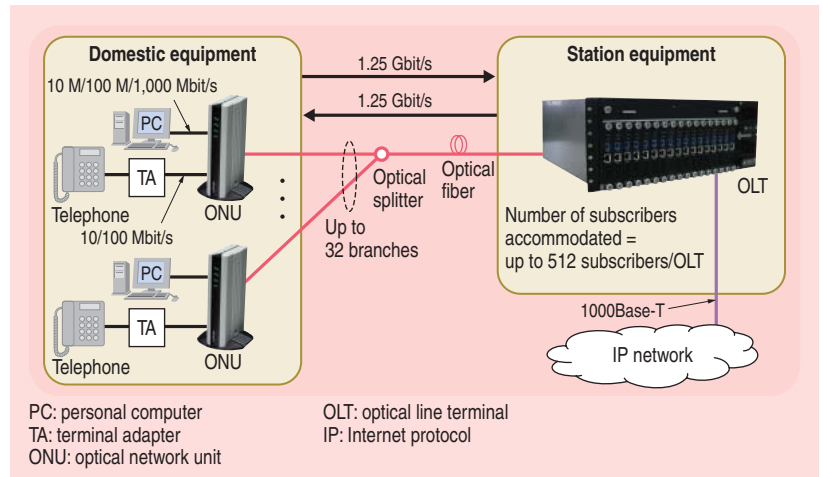

Overview of GbE-PON optical access unit: AMN1500



## High-performance, Reliable, and Compact Gigabit Switches

Networks have recently become a social infrastructure indispensable to business and must be fast and highly reliable. To meet these needs, we marketed the compact gigabit layer 2/3 switch series of 1U (44.45 mm) size compatible with 10 GbE (gigabit Ethernet). The layer 2 series is a box-type layer 2 switch designed for enterprise edge network having firm security capability. On the other hand, the layer 3 series is a line of advanced and stable box-type layer 3 switch with IPv4 (Internet protocol version 4)/IPv6 routing capability, and suited for site-site connection and as core and distribution switches in an enterprise network. Both products can be used to build an authentication and quarantine network based on center authentication in compliance with IEEE802.1X and MAC-VLAN (media access control/virtual local area network), thus enabling centralized control of the authentication configuration and reducing operating costs.

ing capability, and suited for site-site connection and as core and distribution switches in an enterprise network. Both products can be used to build an authentication and quarantine network based on center authentication in compliance with IEEE802.1X and MAC-VLAN (media access control/virtual local area network), thus enabling centralized control of the authentication configuration and reducing operating costs.

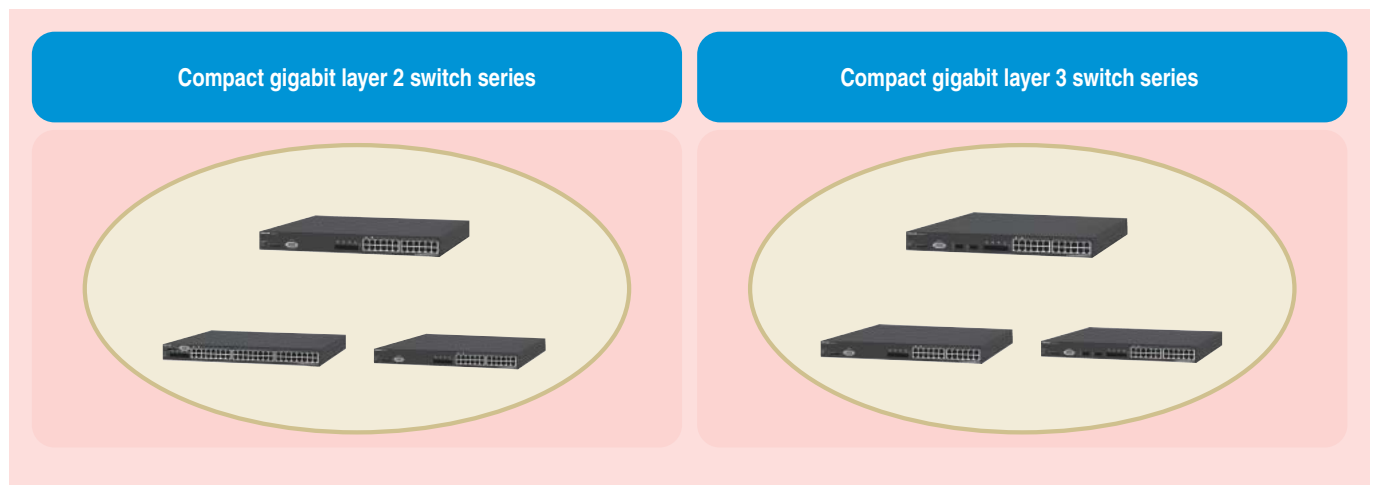

Lineup of the compact gigabit switches



## AMN6200 CWDM System for Metro Access Network

With the spread of broadband networks, demand is growing for the transmission of large quantities of data at low cost in metro access networks and corporate networks. The AMN6200 uses CWDM (coarse wavelength division multiplexing) and transmits large quantities of data. The system can also use forward error correction function to transmit data over long distances without an optical amplifier, thus enabling the economic construction of a network.

[Main features]

- (1) CWDM technology enables 8-signal wavelengths via one optical fiber both ways.
- (2) The 10-Gbit Ethernet signal converter can be equipped with forward error correction and dispersion tolerant function, thus achieving a transmission distance of no less than 80 km.
- (3) The unit incorporates a variety of interfaces, such as 10/100BASE-TX, 1-Gbit Ethernet, 10-Gbit Ethernet, 150-Mbit/s, 600-Mbit/s, and 2.4-Gbit/s.

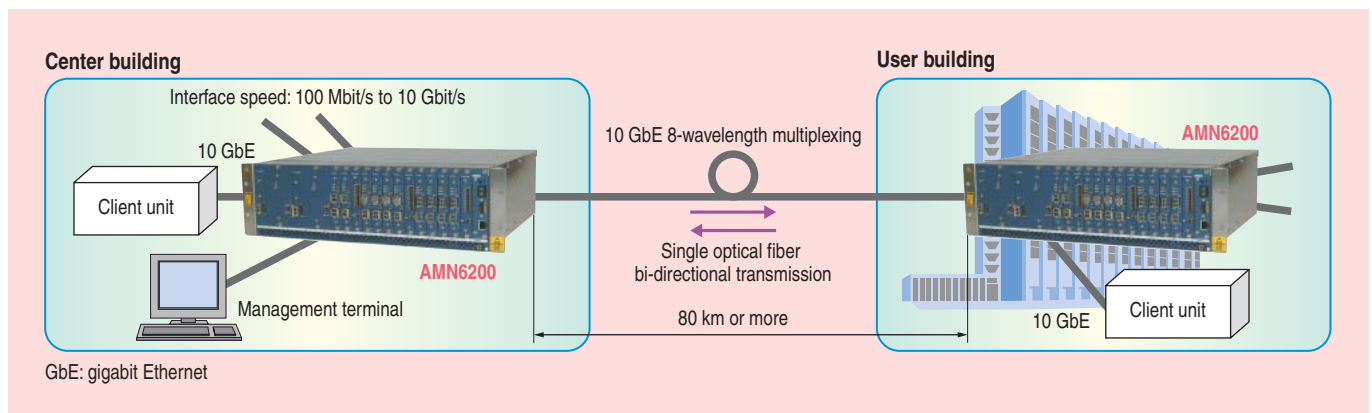

Example of 10-Gbit/s CWDM system configuration



## XFP MSA-Compliant 10-Gbit/s Optical Module

As optical communication networks increase capacity and speed as they evolve from access lines and metro lines to key network systems, demand is growing for the commercialization of small, inexpensive 10-Gbit pluggable optical modules capable of transmitting data over short to long distances. This has prompted us to develop two models of 10-Gbit/s optical modules compliant with XFP (small form factor pluggable) and MSA (multi-source agreement).

[Main features]

- (1) A 1.55- $\mu\text{m}$ -band DFB (distributed feedback) laser diode with the external modulator is used for transmission over distances as long as 40 km.
- (2) A 0.85- $\mu\text{m}$ -band VCSEL (vertical-cavity surface-emitting laser diode) is used for transmission over distances of up to 300 m with a multi-mode fiber.

These products are additions made to existing products having transmission distances of 10 km to complete the XFP series. (Opnext Japan, Inc.)



Optical module compliant with XFP and MSA

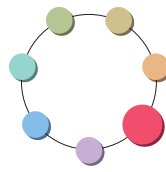

## GPON System for Triple Play Services

PON (passive optical network) technology is designed to provide triple play (video, voice and data) service to households and businesses. The AMN1220 is a GPON (gigabit PON) system compliant with the latest ITU-T G.984 standards. The AMN1220 OLT is a telecommunications-grade network element featuring a built-in hybrid TDM/packet switch fabric. AMN1220 ONTs come in a variety of configurations to support multiple applications and service combinations. The available ONTs include a GST (gigabit single family/small business terminal) and a GMT (gigabit multi-family/multi-business/medium business terminal). The ONTs support interfaces for telephony, 10/100/1,000-Mbit/s Ethernet, DS1 and VDSL2, and can be equipped with an optional RF video interface for connecting to existing coax infrastructures. With these interfaces the system can provide both RF video and IP video simultaneously, thus enabling such enhanced CATV services as HDTV video-on-demand. The telephony and Ethernet interfaces provide access to both conventional telephone and VoIP (voice over IP) services. The Ethernet interfaces enable very high-speed broadband services scaled from a few Mbit/s to up to

Gbit/s. Hitachi has also developed such critical devices as optics and ASICs (application specific ICs) in-house to provide higher quality and more feature-rich components.

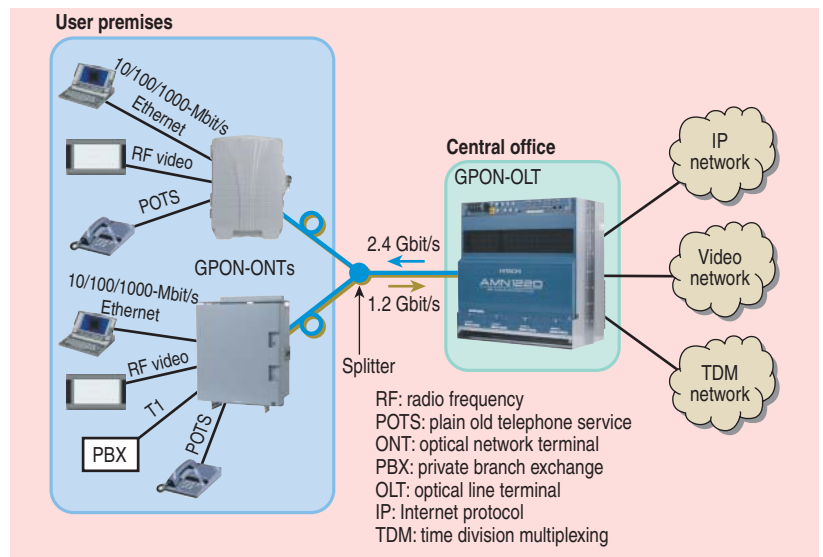

GPON system configuration suitable for triple play service



## Compact 1xEV-DO Wireless Application Platform

Hitachi offers a compact 1xEV-DO (1x evolution-data only) platform as a complete infrastructure for mobile networks. It is designed in compliance with IMT-2000 and 3GPP2 standards. It consists of CPEC (compact EV-DO controller) and Pico-cell. CPEC is a component that supports all 1xEV-DO's center func-

tions, such as BSC (base station controller), PDSN (packet data serving node), and HA (home agent) on one 19-inch 1U (unit: 44.45 mm) standard chassis that is stackable for scalable operation. Pico-cell is a compact base station used to mainly extend coverage to currently out of reach areas such as in a building, airport terminal, shopping mall, and underground complex. Pico-cell can also be used to widely cover sparsely populated areas by adding its optional high power transmission amplifier. The Pico-cell features a lineup of OMNI and three sectors. Data throughput for each sector is transferred at up to 3.1 Mbit/s for forward link and 1.8 Mbit/s for reverse link. Since this platform is designed based on All-IP architecture to reduce nonstandard factors, it can dramatically reduce the cost of related deployment planning, installation, operation, maintenance, and training. In addition to data service, this platform can provide such VoIP (voice over Internet protocol)-related applications as WOS (wireless office system), PoC (push to talk over cellular), VT (video telephony), and FMC (fixed mobile convergence).

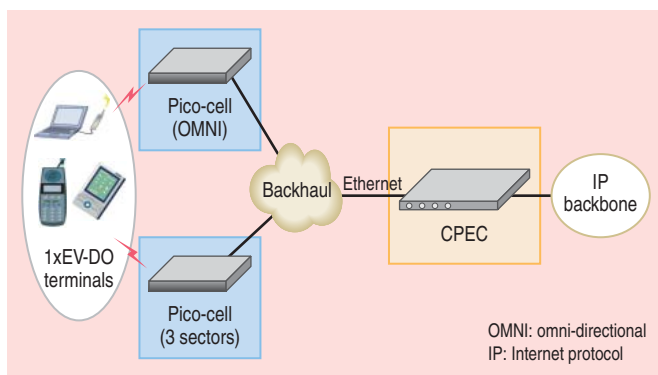

Compact 1xEV-DO configuration