

Energy Storage for Traction Power Supply Systems

Hiroataka Takahashi
Tetsuya Kato
Tomomichi Ito
Fujiro Gunji

OVERVIEW: Environmental considerations have been factored into the development of traction power supply systems in the past, but growing concerns about global warming call for even more innovative environmentally friendly system solutions. Now Hitachi, Ltd. has developed a novel regenerative power management system that efficiently uses stored regenerative train energy by adopting the same lithium-ion batteries used in hybrid drive vehicles, and the system is now poised for practical deployment. The system mitigates voltage drop across the feeder problems with the stored energy when trains are powered, and also effectively reduces peak power demand. A traction power simulator is used to access and configure the optimum system before the regenerative power management system is actually deployed.

INTRODUCTION

WE have seen increasing demand in recent years for traction power supply systems that are more environmentally friendly, energy efficient, and have a smaller footprint. Particularly the growing worldwide concern over global warming calls for innovative new approaches that achieve significantly greater energy savings than in the past. As a responsible global citizen committed to the reduction of greenhouse gases, Hitachi has developed a regenerative power absorbing equipment using batteries called B-CHOP for application to the same lithium-ion (Li-ion) batteries used in hybrid drive vehicles, and the system is now up and running at various sites. This paper provides an overview of the system shown in the photograph in Fig. 1, and gives a brief description of engineering tools used to tailor the system to different installation sites.

DEVELOPMENT BACKGROUND

Beginning in 1985 with the goal of mitigating regeneration lapses, Hitachi developed first regenerative inverters, then a regenerative power absorbing equipment using resistor, and deployed these systems in traction substations. Table 1 reveals that these systems have had different strengths and weaknesses, and it was our objective to combine the strengths of the two earlier approaches with this more recent work to develop a regenerative power absorbing

equipment using batteries that provides significant energy-saving benefits. The system proved effective not only for preventing regeneration lapses by stabilizing feeder voltage levels, but also for mitigating voltage sag, thus improving train acceleration performance. Stabilizing the feeder voltage also stabilizes the regenerative brake power that enables more precise stopping and can reduce wear of mechanical brake shoe. Fig. 2 shows a schematic



Fig. 1—Photo of the Regenerative Power Absorbing Equipment Using Batteries in Operation (Kobe Subway, Seishin-yamate Line, Itayado Substation).

The units shown starting from farthest away to the left are the chopper panel (consisting of arrays of filter panels), the battery panels, and the DC switchgear.

TABLE 1. Comparison of Regenerative Systems
 Comparison of regenerative inverter, resistor type regenerative power management system, and regenerative power absorbing equipment using batteries.

No.	Item	Regenerative inverter	Regenerative absorbing equipment using resistor system	Regenerative power absorbing equipment using batteries (developed in this work)
1	Regeneration scheme (utilizes regenerative power)	Regenerative power uses secondary load from AC system.	Regenerative power consumed by resistor as heat. Regenerative power can't be used.	Regenerative power stored in batteries. Stored power reused as traction power.
2	Can be used to mitigate voltage drop	(No)	(No)	(Yes) Stored power supplied as traction power
3	Installation sites limited	(Yes) Substations equipped with distribution equipment	(No) Can be installed in sites with frequent regeneration lapses.	(No) Can be installed in sites with frequent regeneration lapses or sites where voltage drops occur.
4	Requires supplementary equipment?	(Yes) • Inverter transformer • Harmonic filter • Phase-advance capacitor	(No)	(No)
5	Contribution to energy savings	• Regenerative power applied to distribution loads, etc. • Equipment losses: Comparatively large • Energy saving effects: Yes	• Regenerative power consumed as heat • Energy saving effects: No	• Regenerative power used as traction power • Energy saving effects: Substantial

Fig. 2—Overview of Regenerative Power Absorbing Equipment Using Batteries.
 The regenerative power absorbing equipment using batteries incorporates the strengths of both the regenerative inverter and the regenerative power absorbing equipment using resistor.

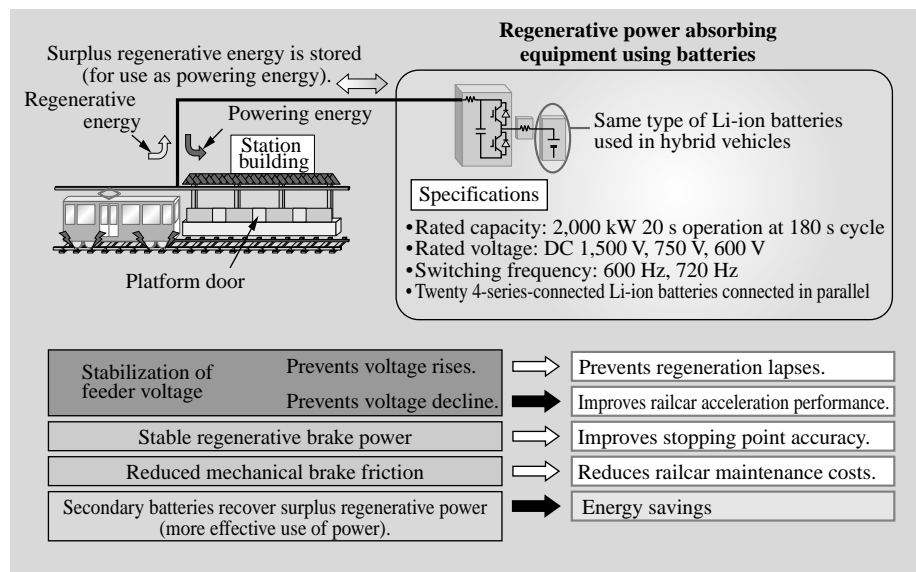

overview of the benefits derived from applying the regenerative power absorbing equipment using batteries.

BATTERY SELECTION

Regenerative power generated by trains has a characteristic that it rises very precipitously. This means that the key to choosing the right battery is the charging characteristics when kinetic energy is being recovered and the discharging characteristics when the

flow of energy is reversed. After comparing various kinds of rechargeable batteries and compiling data on their service life and other characteristics, we settled on Li-ion batteries. Compared with electric double-layer capacitors and NiMH (nickel-metal hydride) batteries, Li-ion cells have higher energy and power densities, and are smaller and much lighter. In short, Li-ion cells are superior to other equivalent secondary batteries, they are manufactured for applications demanding rapid frequent switching back and forth

between charge and discharge, and they are ideal for accommodating the loads of electrified railroads. Advances in material science have extended the service life of Li-ion batteries, so there is no practical problems with using the batteries continuously for 15 years or more under the environment and load conditions prevailing in traction substations. Fig. 3 is a photograph of the general-purpose Li-ion battery module used in our system, which is essentially the same type of module used in hybrid drive vehicles. Concern about the environment and the market for hybrid vehicles will only continue to grow in the years ahead, and this will drive down the cost of Li-ion batteries as the manufacturing economy of scale continues to grow.

B-CHOP SPECIFICATIONS AND APPLICATIONS

B-CHOP Specifications

Let us briefly summarize the key specifications of the commercial version of the regenerative power absorbing equipment using batteries “B-CHOP”:

- (1) Rated capacity: 2,000/1,000/500 kW (20 second operation at 180 second cycles)
- (2) Rated voltage: 1,650 V/820 V (note however that the voltage varies at beginning of charging and discharging.)
- (3) Switching frequency: 600 Hz/720 Hz
- (4) Li-ion battery module configuration: Twenty 4-series-connected cells connected in parallel (for 2,000 kW capacity)

These and other specifications are detailed in Table 2.



Fig. 3—Lithium-ion Battery Module (Manufactured by Hitachi Vehicle Energy, Ltd.)

Lithium-ion batteries are used in hybrid vehicles. Module is rated at 170 V 5.5 Ah.

Circuit Configuration

Fig. 4 is a circuit diagram showing that the B-CHOP system consists of three blocks: the chopper panel, filter panel, and battery panel. A key advantage of the system is that there are no restrictions on where it has to be deployed so it can be installed virtually anywhere. The chopping frequency of the B-CHOP is the same as that of the regenerative power absorbing equipment using register with which we have a good deal of experience, and the ripple of the 12-pulse rectifier is standardized at 600 Hz for the 50-Hz domain and 720 Hz for the 60-Hz domain. These frequencies can be readily modified even in the presence of interference, so B-CHOP seamlessly interworks with other systems.

TABLE 2. Specifications of the Regenerative Power Absorbing Equipment Using Batteries
Key specifications of the commercial version of the system are listed.

No.	Rated voltage*1 (V)	Rated capacity (kW)	Rated current (A)	Load pattern*2	Lithium battery			DC/DC converter	
					Module rating	Module configuration	Rating	IGBT configuration	Frequency*3
1	1,650	500	300	300 A 10 s + 150 A 10 s (charge) 150 A 30 s (discharge)	170 V 5.5 Ah	4S × 5P	680 V 25 Ah	2 parallel connected	600/720 Hz
2	1,650	1,000	600	600 A 10 s + 300 A 10 s (charge) 300 A 30 s (discharge)	170 V 5.5 Ah	4S × 10P	680 V 50 Ah	4 parallel connected	600/720 Hz
3	1,650	2,000	1,200	1,200 A 10 s + 600 A 10 s (charge) 600 A 30 s (discharge)	170 V 5.5 Ah	4S × 20P	680 V 100 Ah	6 parallel connected	600/720 Hz

IGBT= insulated gate bipolar transistor

*1 voltage varies at beginning of charging and discharging (on-site or remote switching options available)

*2 Shows the basic pattern. Intervals on 180-second cycle

*3 Frequency is default specification, but can be changed on site.

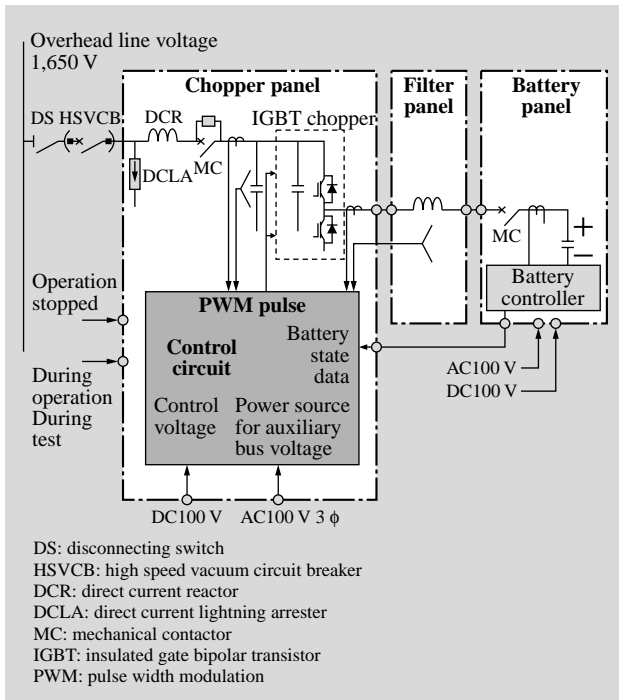

Fig. 4—Circuit Block Diagram of the Regenerative Power Absorbing Equipment Using Batteries. Circuit configuration of the commercial version of the system.

3,300 V 1,200 A IGBT (insulated gate bipolar transistor) is used for the DC/DC converter, and ripple current to the feeder lines and batteries is mitigated by implementing the bidirectional chopper as a 4-multiplex configuration.

The system is designed so that even if 1 system fails, the remaining 2 systems will continue to operate. For the batteries, we adopted twenty 4-series-connected cells as the standard Li-ion battery module. Optimum operational control over the batteries is achieved using battery controllers to monitor and protect the charging state and anode resistance of each Li-ion battery, and send this information to the chopper panel. The chopper panel achieves both fixed feeder line voltage control and prolonged battery life by incorporating feeder line voltage control that maintains the feeder line voltage within a prescribed range using charge/discharge of the batteries, and state of charge control that lowers the state of charge for the next charge (recovery of kinetic energy) during standby.

B-CHOP Applications

B-CHOP is very effective when deployed in substations for correcting significant voltage drops between substations or when deployed at sites for mitigating substantial voltage drops in line terminals.

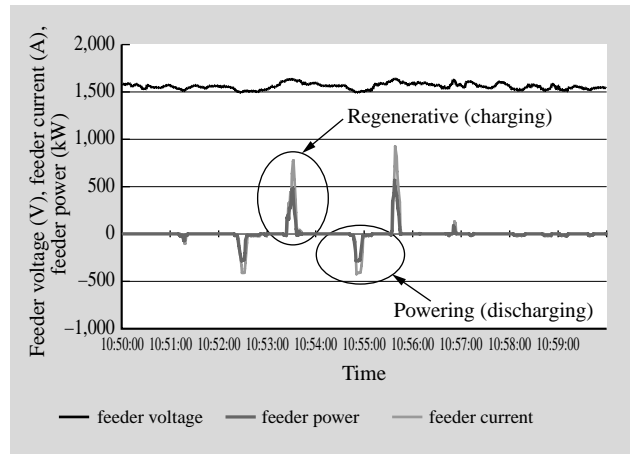

Fig. 5—One-second Sampling Graph of On-site Measurement. Charge/discharge function works the same as initial performance. Feeder voltage absorbs regenerative power and is stabilized. Batteries discharge when train is powered, and voltage drop in feeder is mitigated.

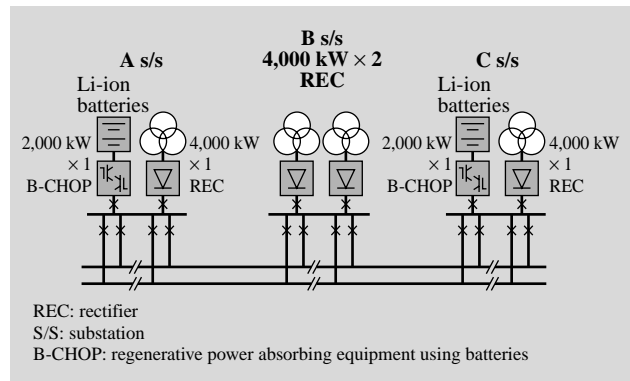

Fig. 6—Deployment Plan Example. Schematic plan showing a system deployment. This arrangement also effectively reduces peak power demand.

Fig. 5 shows a typical operation waveform when a 1-MW B-CHOP was connected to an actual feeder system. One can see that the system contributes significantly to stabilization of feeder line voltage: when the feeder voltage dips below 1,500 V, the drop in voltage is checked as the batteries start to discharge, and when the feeder voltage climbs above 1,650 V, the increasing voltage is restrained as the batteries start to charge. It is thus apparent that the device greatly contributes to feeder voltage stabilization. Fig. 6 shows that when B-CHOP is installed in 1 bank of a conventional 2-bank substation when the rectifier is upgraded, this complements the rectifier and permits recovery of regenerative energy. Even in the event of a power outage, B-CHOP is unaffected and continues to operate. Power is supplied from the discharging

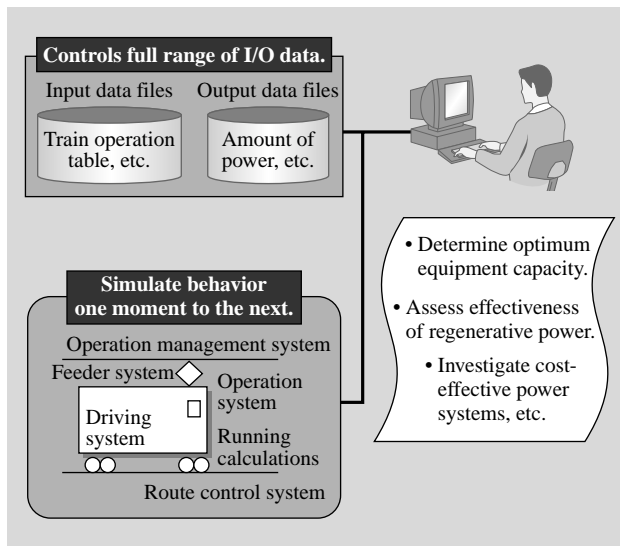

Fig. 7—Railway Comprehensive Power Simulator. Markedly improved over our existing simulator, and endowed with powerful engineering tools.

batteries, so trains in the vicinity of the substation continue to run.

Engineering Support for B-CHOP Deployments

In order to derive the most effective use from B-CHOP while making the minimum required investment, a certain amount of engineering is required to determine

- (1) system installation sites,
- (2) optimum system capacities, and
- (3) alignment with other peripheral systems.

When planning a B-CHOP deployment, this engineering work is aided by New-Jumps, a comprehensive power simulator developed by Hitachi

for application to electrified railways to determine the optimum placement and capacity of B-CHOP systems. The simulator includes an energy storage analysis model, calculates the most effective deployment sites and minimum required capacity, and provides valuable engineering support tools for assessing the effects of implementing the system before it is deployed. As illustrated in Fig. 7, use of New-Jumps enables us to design and propose optimum traction power systems tailored to different system needs and requirements.

CONCLUSIONS

This paper described an energy storage for traction power supply system that effectively reduces greenhouse gas emissions. Hitachi remains committed to environmentally friendly technological solutions that reduce greenhouse gas emissions, and to research and development on innovative traction power supply systems that address the pace and direction of various changes.

REFERENCES

- (1) H. Takahashi, "Effective Use of Regenerative Power," *Railroad and Electrical Engineering* (Jun. 2005), in Japanese.
- (2) T. Ito, et al., "Development of a Regenerative Power Absorption Unit for Lithium Batteries," *Technical Meeting on Transportation and Electric Railway, IEE Japan* (Sep. 2005), in Japanese.
- (3) H. Takahashi, et al., "Verification of an Effective Method for Using Regenerative Power," *42nd Symposium of Cybernetics*, p. 606 (Nov. 2005), in Japanese.
- (4) M. Ito, et al., "Overview of Filter Trials for Regenerative Power Absorption Unit for Battery Systems," *Railway and Electrical Engineering* (Jan. 2007), in Japanese.
- (5) H. Takahashi, et al., "Verification of an Effective Method for Using Regenerative Power," *Rolling Stock and Technology* (Feb. 2007), in Japanese.

ABOUT THE AUTHORS



Hiroataka Takahashi
Joined Hitachi, Ltd. in 1991, and now works at the Transportation Systems Integration Department, the Transportation Systems Division, the Industrial Systems. He is currently engaged in the engineering of traction power supply systems.



Tetsuya Kato
Joined Hitachi, Ltd. in 1989, and now works at the Power Electronics Design Department, the Information & Control Systems Division, the Information & Telecommunication Systems. He is currently engaged in the development of power converter systems for railroads. Mr. Kato is a member of the Institute of Electrical Engineers of Japan (IEEJ).



Tomomichi Ito
Joined Hitachi, Ltd. in 2000, and now works at the Power Electronics Systems Unit, the Advanced Inverter System R&D Center, the Hitachi Research Laboratory. He is currently engaged in the development of high power converter systems. Mr. Ito is a member of IEEJ and the Institute of Electrical and Electronics Engineers (IEEE).



Fujio Gunji
Joined Hitachi, Ltd. in 1994, and now works at the Transportation Substation Systems Engineering Section, the Industrial Systems Supervisory Department, the Kokubu Engineering & Product Division, the Hitachi Works, the Power Systems. He is currently engaged in the engineering of traction power supply systems.