

Industrial Infrastructure Business

Industrial Systems

Steel Plants

Automotive Systems

Semiconductor Manufacturing
and Inspection Equipment

Biotechnology and Scientific Instruments

HITACHI TECHNOLOGY
2008-2009

Development of High Capacity Hermetic Centrifugal Chillers Aimed at the International Market

Hitachi has developed a hermetic centrifugal chiller that supports both high capacity and energy saving. This product is designed to meet the increased requirement for high capacity of heat source equipment for IT (information technology) industrial plants and larger buildings and to contribute to reduction of CO₂ exhausts. Hitachi intends to establish overseas production bases to provide the global market with the products brought by this new technology.



Kazuo Watase (left), General Manager, Design Department Manager; Masatoshi Terasaki (right), Senior Manager, Design Department, Tsuchiura Air Conditioning Works, Air Conditioning System Group, Hitachi Appliances, Inc.

Front Runner of Centrifugal Chiller Manufacturers

Hitachi is an established manufacturer of centrifugal chillers for more than 75 years. In the late 1980s, CFC (chlorofluorocarbon) that was used for refrigeration equipment (including refrigerator, car air-conditioner, and turbo refrigerator) became a social issue as one of the factors that destroy the ozone layer. In 1993, Hitachi, as a pioneer, adopted in its centrifugal chillers HFC (hydrofluorocarbon)-134a as refrigerant that does not contribute to destruction of the ozone layer. More than 1,300 refrigerators have been manufactured since then, and with all technologies combined from all companies of the Hitachi Group, three models [5,627 kW (1,600 USRT), 6,330 kW (1,800 URST) and 7,033 kW (2,000 USRT)] have been successfully developed by increasing capacity of high efficient model series. These high efficient model series won "The Japan Machinery Federation Chairman's Award" of the 25th Excellent Energy-saving Equipment Commendation in 2003. Hitachi has been committed to further develop not only higher capacity products but also energy saving and compact ones.

Highest Energy Saving in the Industry in Addition to Higher Capacity

We focused our development efforts on the market trend. Behind the trend were the increased capacity and efficiency requirement of centrifugal chillers as a result of the recent large-scale domestic capital investment in plant and equipment of electronic devices including semiconductors and liquid crystal panels. Also needs for high capacity centrifugal chillers are increasing in rapidly growing China, South East Asia and the Middle East. We successfully developed a new hermetic high capacity refrigerant cooling motor and raised cooling capacity up to 7,033 kW (2,000 USRT) as compared with the conventional cooling capacity of 5,274 kW (1,500 USRT) in order to respond to these needs.

The product has achieved the capacity of 7,033 kW (2,000 USRT) and the COP (coefficient of performance) of 6.4, which contribute to a significant energy saving. Fortunately the development activities were conducted in our Tsuchiura Air Conditioning Works that has been engaged in manufacturing of not only large tonnage chillers but also various fluid machines. Liquid analysis technologies within the Hitachi Group were all combined together to optimize the profile of a diffuser with three-dimensional impellers and vanes and increase liquid performance to a great extent. As a result we succeeded in achieving high efficiency of a centrifugal compressor, the heart of a centrifugal chiller. At present China puts top priority on the issue of establishing the resource saving society and requires manufacturers to indicate an energy efficiency grade on their centrifugal chillers. Our new product exceeds the first class energy efficiency of COP6.1 substantially. This product also features space saving, broader operational range and support for inverter control.

Starting up Overseas Production Base to Further Aimed at Globalization

China, among overseas countries, is believed to have the centrifugal chiller market four times the size of the Japanese market. Although USA manufacturers account for an overwhelming share in China, their focus is not on the energy-saving COP6.4 grade turbo refrigerators. We are actively expanding our share of new products that have both high capacity and energy-saving features. For this purpose, Hitachi Air-conditioning & Refrigerating Products (Guangzhou) Co., Ltd. is starting up a manufacturing plant of large tonnage chillers as a production base for overseas markets, apart from our Tsuchiura Air Conditioning Works for domestic markets. We continue to be committed to combining all technologies from the Hitachi Group and manufacturing products that respond to the global warming and energy issues.

Energy Conservation Control System

To reduce global warming, energy control systems for utility equipment tailored to environmental management of individual companies are being pursued. For this, Hitachi has developed an energy conservation control system that forecasts demands of heat, electricity, and steam and creates an efficient operation approach to control the utility equipment based on its forecasts. This system forecasts the energy demands of heat, electricity, and steam on the current day according to the past demands and current information of air temperature and humidity. In addition, this system employs improvements in forecasting accuracy by correcting the forecast demand on a regular basis based on the current demand to accommodate abrupt demand changes. Based on the resulting demand forecast, plans of highly-efficient operation for energy supply equipment such as freezers and boilers are automatically created and accurate start/stop commands for the equipment can be output to provide stable energy supply, minimize the generated CO₂ volume, col-

lect the maximum amounts of exhaust heat, and reduce energy losses.

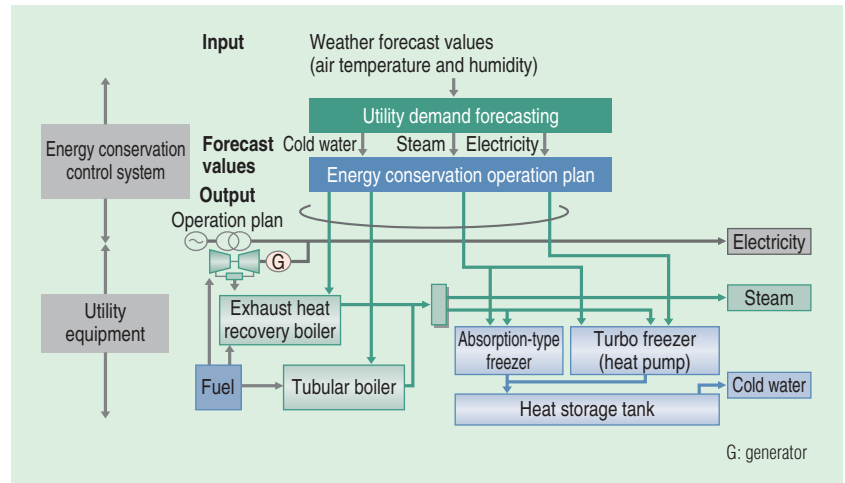

Example of application of the energy conservation control system

High-voltage Direct Inverter for Cement Kiln

A twin-drive inverter control system was applied to cement kilns to directly connect and drive two motors using two high-voltage

direct inverters. This equipment operates highly efficient and high-voltage large-capacity motors without using any output transformer.

[Main features]

- (1) A torque balance control system enables the two inverters to drive the motors in unison to handle sudden torque changes and for restarting while the motors are running.
- (2) When the equipment is set up, a motor and an inverter are installed. If enhancement of the equipment capacity is required in the future, another motor and inverter with the same capacity can be added to the existing motor and inverter. This allows for planning for the optimum use of equipment.
- (3) This control system allows for degeneration control by switching from the command equipment to other inverter when inverter is under maintenance, inspection or if it fails.
- (4) By employing dual cooling fans, the inverter achieves improvement reliability.



2,000-kVA high-voltage direct inverter (one set) (Two sets of this product work in unison for twin-drive control.)

HF-W7500RM Industrial Computer

Hitachi released the HF-W7500RM industrial computer, for use as a server.

Much higher performance and larger capacity are being required for industrial computers to support the increase in the processing as a result of miniaturization in manufacturing processes and for pursuing productivity improvement in operation management. Suited for a broad range of the assembly application including the semiconductor manufacturing equipment and logistic systems requiring the processing performance, both reliability and maintainability are expected.



HF-W7500RM industrial computer

[Main features]

- (1) High-reliability design assuming 24-hour continuous operation and a lifetime of 10 years
- (2) Long-term stable supply for three years after the release. The maintenance service for up to 10 years is provided.
- (3) High-performance, power-saving Dual Core Intel* Xeon* processor LV (2.0 GHz) is adopted.
- (4) The powerful functions for recovery support and failure analysis support are provided.
- (5) Maximum capacity of approximately 2.5 Tbyte. Large-capacity storage supporting RAID5 (redundant arrays of independent disks 5)
- (6) RoHS (Restriction of Hazardous Substances) compliant
- (7) Compliant with International standards: UL (Underwriters Laboratories), CSA (Canadian Standards Association), CE (Council of Europe), and FCC (Federal Communications Commission)

* See "Trademarks" on page 90.

AC Drive for Mining Dump Trucks

Super large power shovels and dump trucks are vital to operation of open-pit mines throughout the world. These super large dump trucks have been adopting AC (alternating current) drive systems that obtain their drive power from the inverter and AC motor using a diesel engine as the power source to improve efficiency and maintainability. This time, Hitachi developed an AC drive system for dump trucks in the payload class of 190 t.

The inverter, a 4.5-kV high-voltage, large-capacity IGBT (insulated gate bipolar transistor) from Hitachi, is employed for its compactness and high efficiency.

In addition, a water-cooling system conveys the heat generated from the electrical circuit to an external radiator. As a result, the electrical circuit can be fully enclosed to ensure high reliability in mines where much dust exists.

Also, brake resistors that absorb energy to slowdown the vehicle are divided into four units to improve the cooling performance and reliability and achieve a highly efficient, electri-

cal braking power.

In the future, Hitachi will develop AC drives for dump trucks with larger capacities to expand the series.



Dump truck for mines and control cabinet containing the inverter (left top)

Energy-saving Transformers

Hitachi has developed new energy-saving transformers including the oil-immersed transformer 3 series and the molded transformer 2 series. This series of amorphous transformers has exceeded Japan's "top runner" standard significantly by substituting amorphous alloy for the core material.

This series has achieved higher efficiency, smaller size, and lower noise than existing amorphous transformers and meets the market's needs of energy savings for a general-purpose, high-end, top runner transformer.

Hitachi has developed the high space factor coil technology for molded transformers and has succeeded in reducing the amount of molding resin through improved coil shape. By reducing the coil size and optimizing the design of the core to conserve energy and reduce the overall size of the transformer, Hitachi has developed mold-type compact series and added it to a whole lineup of super amorphous transformer products. The series has enabled an amorphous molded transformer to be easily contained in the cubicle high power control system.

For oil-immersed transformers, Hitachi has achieved smaller coils, oil savings and lighter weight.

(Hitachi Industrial Equipment Systems Co., Ltd.)



Energy-saving transformers

X200 Series Compact Inverter



X200-002SFEF (Single phase 200 V, 0.2 kW)

The X200 series compact inverter has the optimal functionality for a fan and a pumping mode.

[Main features]

(1) Integrated EMC (electromagnetic compatibility) filter (European version only)

Improved cost and space reduction compared with the external EMC filter (EN61800-3 cat.C1.C2)

(2) Improved trip avoidance function

An over current and over voltage suppressing function is incorporated to reduce inverter tripping.

(3) Automatic energy-saving function

The X200 delivers "realtime" energy-saving operation for users' fan and pump applications.

(4) Emergency stop function

Shuts off inverter output by hardware without having to use software to achieve an effective emergency stop.

(5) Side-by-side installation

Since an inverter can be installed horizontally, space can be used most effectively.

(6) Micro-surge voltage suppress function

Hitachi original PWM (pulse width modulation) control suppressing motor terminal voltage less than two times of inverter DC (direct current) voltage E

(Hitachi Industrial Equipment Systems Co., Ltd)

Inkjet Printer with Printing Inspection Function

Consumers as well as vendors expect food manufacturers to ensure food safety and implement stringent controls. There is a strong demand for inkjet printers for printing of use-by dates in a timely and adaptable manner. Recently increased number of printing inspection machines has been installed in the post-processes to improve printing quality. Hitachi has developed a new inkjet printer to respond to this demand.

[Main features]

- (1) A printing inspection machine and an inkjet printer are integrated.
 - (2) Dust-proof and drip-proof [IP (International Protection) 55] stainless steel [SUS (stainless used steel) 304] is used for the body, which is ideal for production lines of beverages, foods and medicines.
 - (3) A tracking system of defective products is installed as a standard.
 - (4) Improved inspection accuracy
 - (5) A function to detect misprints by comparing features of similar letters
- (Hitachi Industrial Equipment Systems Co., Ltd.)



Inkjet printer with printing inspection function

New Induction Motor: Outdoor IP55 Series

Hitachi has developed a new induction motor, the outdoor IP (International Protection) 55 series, which has a protective structure of IP55 and heat resistance class of F (E rise). In the world market, the protective structure of IP55 has been set as a global



New induction motor: outdoor IP55 series, 2.2 kW, four poles

standard and set makers are expected to follow this trend in adopting their motor types.

[Main features]

- (1) Reinforced dust-proof and drip-proof structure (protective structure of IP55)
- (2) Enhanced heat resistance class of F (E rise) to improve reliability
- (3) Enhanced application-specific features including CE mark approval and a broader range of voltage and frequency
- (4) Mounting dimensions compatible with existing model series

[Models to be released]

0.4-3.7 kW, two, four, and six poles (six poles up to 2.2 kW; the series will be expanded in succession.)

[Appearance]

- (1) 0.4, 0.75 kW: Sheet steel frame (0.75 kW, six poles: Aluminum alloy)
 - (2) 1.5-3.7 kW: Aluminum alloy frame
- (Hitachi Industrial Equipment Systems Co., Ltd.)

Completion of Large Size Centrifugal Pump for A. D. Edmonston Pumping Plant in the State of California

In June 2007, 1st unit of large size centrifugal pump for A. D. Edmonston Pumping Plant has completed commissioning test, and started commercial operation.

A. D. Edmonston Pumping Plant, which is operated by the Department of Water Resources of the State of California, is the most important facility for supplying water for Southern California. The plant's 14 centrifugal pumps perform the largest pumping operation in USA.

This contract is to sequentially replace four of the old pumps in 14 existing pumps with new pumps by 2011. The new pumps employ the latest technology, and achieve one of the highest pump efficiency (92%) in the world for similarly rated pumps in flow and speed. These pumps will contribute to providing a stable water supply for Southern California with highly efficient operation.

[Pump specifications]

- (1) Pump type: Vertical multi-stage turbine pump
- (2) Rated flow: 8.92 m³/s
- (3) Rated head: 600.5 m
- (4) Rated speed: 600 rpm
- (5) Motor output: 59,656 kW
- (6) Guaranteed pump efficiency: 92%
- (7) Discharge inner diameter: 1,920 mm

These new pumps have achieved high reliability and much higher efficiency than the existing pumps. Based on this experience, Hitachi expects to meet the growing demands of water projects throughout the world.

(Hitachi Plant Technologies, Ltd.)



Completion of pump assembly

Air Conditioners with Independent Operating Functions for Use in Shops and Offices



System (internal + external units) appearance (Model 224)

Hitachi Appliances, Inc. is the first in the industry to sell industrial air conditioners, (models 40 to 335, 13 models ranging from 4.0 to 33.5 kW), that allow individual operation and temperature setting of each unit in an air-conditioning system consisting of several connected units. The system supports minimum two (Model 40) up to four internal units (Model 335) allowing individual operation, stopping and temperature setting. They can be connected to a single external unit to save space. It also contributes to energy saving by enabling individual operation of several units installed in one large room, depending on the load of each unit. An external unit for all models is designed for side blowing to further contribute to space savings. The system has a new DC (direct current) inverter scroll compressor that achieves the top class efficiency in the industry with a heating and cooling average COP (coefficient of performance) of 4.71 and annual energy performance factor of 5.4 (Model 63). It also features a variety of demand control functions, a night shift mode that reduces noise at night, and it does not require special preparatory cleaning of the existing plumbing when installed.

(Hitachi Appliances, Inc.)

Cushion Tire Forklifts

TCM Corporation has fully remodeled and launched all five models of battery forklift (maximum load of 1,500–3,000 kg) with cushion tires (all rubber low profile tires) for the North American market. For maneuvering and cargo handling, the new forklifts feature a high performance AC (alternating current) motor that provides ease of operability, highly improved safety, interior comfort and



Battery forklift with cushion tires (maximum load of 2,500 kg)

operability. TCM expects the introduction of these new models to increase sales from 100 forklifts to 300 forklifts per year.

[Main features]

(1) Improved basic performance by adopting high performance AC motor for maneuvering and cargo handling

Driving speed (no load): previously 16 km/h improved to 17.5 km/h

Cargo lifting speed (no load): previously 620 mm/s improved to 640 mm/s

Gradability (loaded): previously 13% improved to 17%

(2) Improved interior comfort: Increased floor room (increased floor area by about 23%.)

(3) Improved ease of getting on and off: Widened platform width (from 415 mm to 520 mm)

(4) Improved operability: Smaller diameter of a steering wheel (reduced diameter from 360 mm to 300 mm)

(5) Improved safety: Preventative measures for accidental operation (maneuvering and cargo handling are only enabled when a driver is seated.)

(TCM Corporation)

EH3500AC Dump Truck

Hitachi Construction Machinery Co., Ltd. has developed the EH3500ACII large off-road dump truck for strip mines. Hitachi also has a large share of the market for large hydraulic excavators with superior performance and reliability in the same market sector. The EH3500ACII has many features based on reliable large excavator technology.

[Main features]

(1) Highest payload in its class

(2) Excellent driving performance and efficient cycle time

(3) Highest durability in its class

(4) Low maintenance time and cost with AC (alternating current) drive system

(5) Trolley option available

The previous model, the EH3500 with a conventional DC (direct current) drive system has been widely delivered and well accepted by the market. Hitachi Construction Machinery and Hitachi, Ltd. have been developing AC drive system for off-road dump truck with Hitachi's recent 4.5-kV IGBT (insulated gate bipolar transistor) and it has

finally been realized in the EH3500ACII. Challenge for developing an AC drive system for dump trucks is its harsh environment of operation compared to factories or train/locomotive applications. Water-cooling system of the IGBT and completely enclosed control cabinet design is the key factor for overcoming such severe operating conditions that are dusty and hot and cold climates.

(Hitachi Construction Machinery Co., Ltd.)



Specifications

Gross machine weight	325,000 kg
Nominal payload	168,000 kg
Engine power	1,491 kW
Maximum speed	56 km/h
Maximum height	6,770 mm
Maximum width	8,010 mm
Maximum length	13,500 mm

Appearance and specifications of dump truck EH3500AC

Co-development of Hot Rolling Control Simulator

Hitachi has completed co-development of a hot rolling control simulator in cooperation with Mitsubishi-Hitachi Metals Machinery, Inc. (MHMM).

Since hot rolling requires high-accuracy control of strip thickness, width, and temperatures, investigation of control systems and pre-engineering of equipment designs are crucial.

This development focused on strip thickness and temperature controls in finishing rolling and coiling temperature control. Knowledge of the physical phenomena of controlled objects and mechanical properties held by MHMM and the control simulation technology of Hitachi worked together to create a practical system.

The finishing rolling control simulator is applicable to mini-mill rolling in addition to conventional tandem rolling as well as a variety of uses such as setup control results check and accuracy evaluation of individual models (loading model, temperature prediction model, etc.) using the actual data.

For coiling temperature control, the cooling model to be used in setup control was made highly accurate by introducing the newest experimental knowledge for boundary conditions (heat transfer coefficients, etc.). In addition, the simulator system handles the functions of applying the strip speed and finishing mill delivery

temperature changes. Under various rolling and disturbance conditions, the cooling behavior of a coil can be continuously simulated to evaluate the temperature control accuracy and effect of various dynamic controllers.

The developed system is built on standard software. Since equipment changes properly reflect in the changes of corresponding data, the system can be effectively used for future advances in hot rolling control.

(Development completed: March 2007)

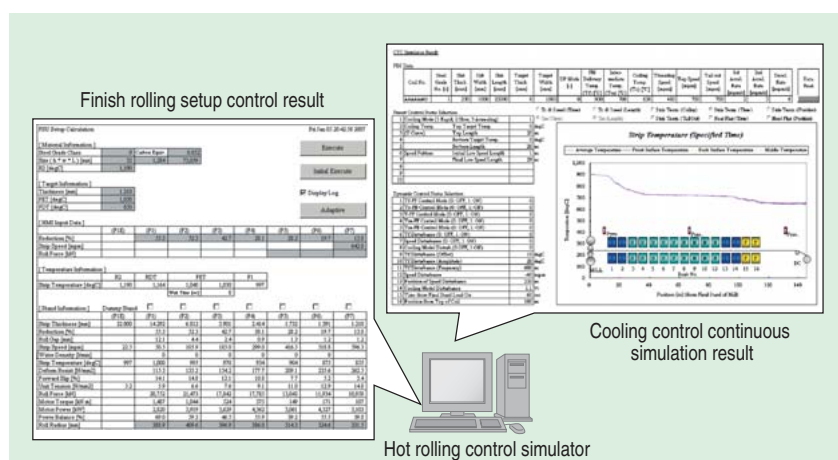

Example of simulation screen

Large-capacity IGBT Drive System for Hot Rolling Mill

Hitachi commercialized a high-voltage large-capacity IGBT (insulated gate bipolar transistor) drive system (single converter rated output capacity of 5.4 to 15 MVA) for hot rolling main machines.

The IGBT applied to this system is a multi-purpose IGBT applied to various uses, not only for steel mills, and a stable supply of high-quality IGBTs now can be provided for a long time.

[Main features]

(1) A multi-purpose 3.3-kV/1.2-kA (2.4-kAp) IGBT was employed to extend the product cycle.

(2) With two IGBTs connected in serial, the output voltage was increased to allow employing an AC (alternating current) motor in the AC 3-kV class.

(3) With main circuit cell units connected in parallel, capacities in series were made available so that the optimum IGBT drive systems matching the users' demands can be provided.

[Rated output capacity lineup]

Single-bank configuration: 5.4 MVA, 10.2 MVA, 15 MVA

Two-bank configuration: 20.4 MVA, 30 MVA

Item	Specification				
Circuit system	NPC (3-level) type inverter				
Applicable motor	3-terminal			6-terminal	
Number of IGBT panels	1	3	3 panels × 2 banks		
Number of cell units in parallel	1 in parallel	2 in parallel	3 in parallel	2 in parallel × 2 banks	3 in parallel × 2 banks
Rated output capacity (MVA)	5.4	10.2	15	20.4	30
Rated output voltage (Vrms)	4,090				
Cooling system	Water-cooling type (deionized water)				
Overload specification	150% (60 s)				
Conversion efficiency	At least 98% (converter + inverter)				



Basic specifications (left) and external view of IGBT drive system (right)

Electrical Equipment for New Wide Continuous Pickling and Cold Rolling Line Delivered to Maanshan Iron & Steel Co., Ltd. in China

The electrical equipment for a new wide continuous pickling and cold rolling line, called "MGC2," delivered to Maanshan Iron & Steel Co., Ltd. in Anhui Province, China started commercial operation and is running smoothly. This rolling equipment consists of a five-stand rolling mill that mainly produces cold-rolled sheet for automotive exposed bodies whose demand has increased in recent years in China. The mill stand is a 6-high UCM (universal crown mill) and the mill uses the newest electrical control technology, which can produce various steel sheets from 0.25 mm thin thickness to 2,000 mm wide automotive exposed sheets.

By applying hardware combining the R700 series PLC (programmable logic controller) capable of achieving high-speed calculation and communication via an optical network, and applying the optimum control system for mill section, production can be stable and continuously

operated, and it has shortened the commissioning period before the start of commercial operation.

Also, with the servo winding control technology that dynamically controls the thickness and tension upon product winding by tension reel for thin gauge, operators working load has been reduced compared with previous plants.

(Startup time for commercial operation : September 2007)



Operation room (a) showing one-person operation, and rolling mill main motors (b)

Commercial Operation of Continuous Hot Dip Galvanizing Line Started in Japan

The No.4 continuous hot dip galvanizing line delivered to the West Japan Works (Fukuyama District) of JFE Steel Corporation and the No.3 continuous hot dip galvanizing line delivered to the Kashima Steel Works of Sumitomo Metal Industries, Ltd. started commercial operation in succession and are running smoothly. For both companies, this newly-constructed facility represents more than ten years efforts to achieve high-quality automobile

outer panel production and the realization of production supporting quality requirements that are being more stringent year by year that previously had been an issue.

For these requirements, the high-quality steel plate production and stable operation were achieved by the high-response, multi-functional IGBT (insulated gate bipolar transistor) drive system with Hitachi's original tension control system. Improved quality control is supported by introducing quality handling functions that manage steel plate quality data through better correlation with steel plate positioning. Additionally, ripe experience of newly installing such processing lines both inside and outside Japan has contributed to Hitachi's know-how for commercial operation by the shortest schedule.



Outside view of West Japan Works of JFE Steel Corporation (left) and galvanizing equipment department (right)

Continuous Cold Rolling Electromechanical Equipment Delivered to Union Steel Co., Ltd. in Republic of Korea

The brand-new pickling and continuous cold rolling electro-mechanical equipment delivered to Union Steel Co., Ltd. in

Republic of Korea started the commercial operation and is running smoothly.

The equipment is used to efficiently produce high-quality cold rolled steel plates as the intermediate materials for high-class galvanized steel plates, high-class color steel plates, and high-class printed steel plates for home electronics, furniture, building materials, etc. The equipment for pickling hot rolled steel plates and the rolling machine consisting of five stands are laid out in serial, so cold rolled steel plates can be produced in non-stop mode.

A compact dynamic setup server combining the industrial PC (personal computer) HF-W, and the rolling machine forecasting model together is employed for the first time to produce products with various thicknesses, widths, and steel types precisely. The combination of resulting computation/setting of the optimum set values for the rolling machine, thickness control employing the optimum control theory, and the high-voltage IGBT (insulated gate bipolar transistor) drive system achieves the high-accuracy thickness quality against the full length of the product steel plate and improves the throughput. At the same time, troubles are minimized and stable operation of the equipment is achieved in 0.25-mm sheet production as well.

(Start of commercial operation: April 2007)



Operation room during one-person operation and cold rolling equipment (right bottom)

Inverter for GM 2-mode Hybrid System

Hitachi started to supply inverters for General Motors Corp. (GM)'s dual-mode hybrid system following GM's BAS (belt alternator starter) hybrid system that entered the market in July 2006. The inverter named the "TPIM (traction power inverter module)" contributes to the 30% overall fuel economy improvement according to GM. The main features of the TPIM are as follows:

- (1) Two inverter functions inside one unit to control two motors (60 kW) separately in the GM dual-mode hybrid system
- (2) Control charge and discharge to a 300-V battery
- (3) An HVIL (high voltage interlock loop) is incorporated to assure safety in case of a crash and on the like.

Hitachi started delivering the TPIM in September 2007.



"TPIM" inverter and GM Tahoe with the TPIM

Distance Control Assist System and Navigation-enabled Function in its Intelligent Cruise Control

Hitachi has produced the distance control assist system and added a navigation-enabled function to its intelligent cruise control for the Nissan Fuga. The following describes the functions of these systems.

(1) Distance control assist system

When the driver lets up on the gas pedal, the system automatically applies the brakes smoothly to decelerate the vehicle and help the driver maintain an appropriate following distance. If the driver presses the gas pedal, the gas pedal actuator moves the gas pedal upwards to assist the driver to release the cruise control. If the system determines that braking is required, an indicator will appear on the instrument panel and a warning will sound. The system will move the gas pedal upwards to assist the driver to switch to the brake pedal.

(2) Navigation-enabled function

Utilizing route-information

fed through the on-board navigation system, the intelligent cruise control system can modulate the vehicle-speed in anticipation of the next curve on the road.

Distance control assist system is available in Japan and will be provided for USA market. The navigation-enabled function is added in its intelligent cruise control for Japan market.

These both systems greatly assist driving the vehicle.

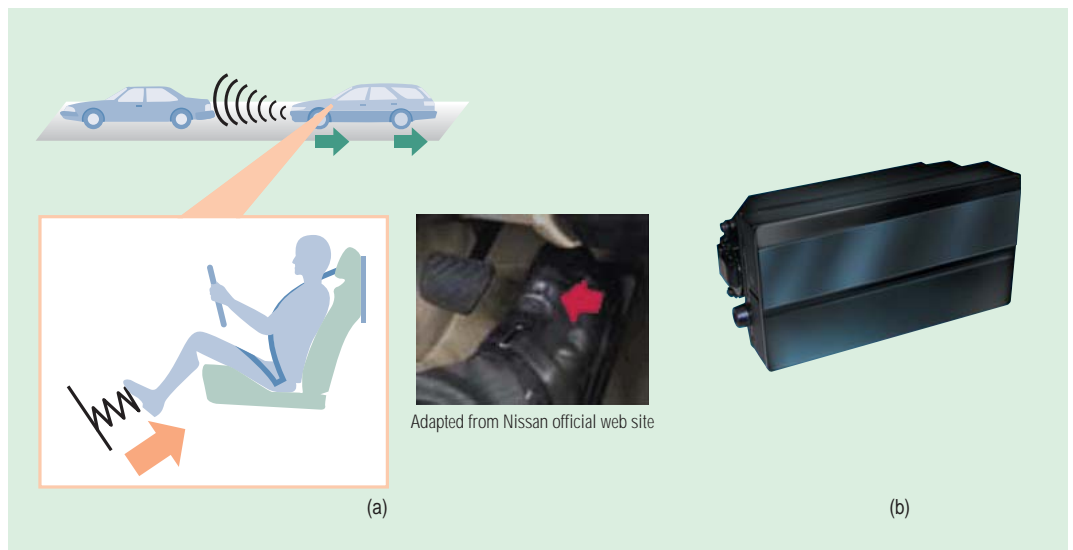

System configuration (a) and control unit (b)

Multi-chip Module Mounted Engine Control Unit

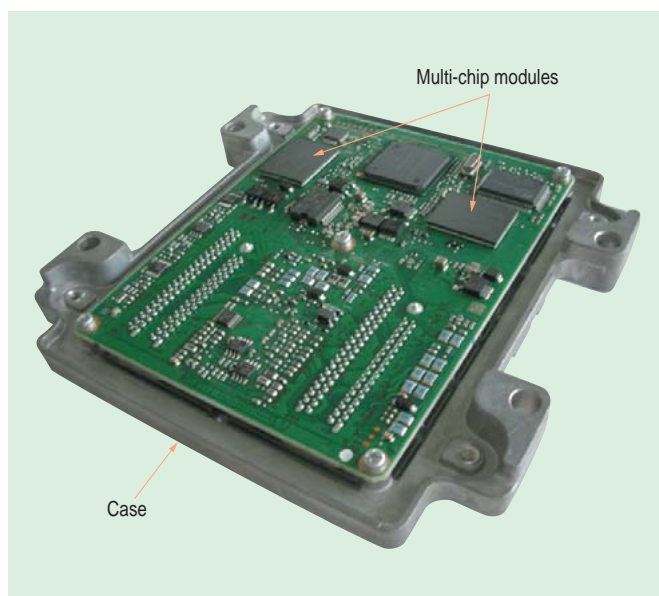

Overview of multi-chip module mounted engine control unit

Hitachi has developed an engine control unit with a multi-chip module that has increased heat dissipation, by integrating multiple semiconductor ICs (integrated circuits) into one package. This product is designed to meet the needs for more compact size and greater heat dissipation capacity in a high performance control unit to respond to strict environmental regulations.

In this development, Hitachi has succeeded in reducing the total number of parts by integrating peripheral circuits except for the microprocessor into a custom IC and further integrating multiple custom ICs into a multi-chip module using bare chips.

Hitachi has also achieved better heat dissipation by adopting a more efficient heat dissipating material for substrates and creating a better path to the case that helps dissipate heat.

Robust Airflow Sensor for Contamination in Diesel Engine Applications

The new European exhaust gas emission regulation, EURO 5, has the world's strictest emission limits for automobiles. To meet this stringent regulation, automobile manufacturing companies have developed new engine control systems. Especially necessary is a drastic reduction of PM (particulate matter) and NOx (nitrogen oxide) in diesel engine applications. Therefore, the companies are placing a strong emphasis on installation of electrical fuel injection systems using AFSs (airflow sensors). In AFSs for the diesel applications, degradation of AFS output characteristics by contaminants such as carbon is an inevitable problem.

To make a breakthrough with this contamination problem, the entire contamination mechanism was analyzed in detail. A new cyclone bypass passage utilizing inertial separation was developed. This new bypass passage dramatically reduced the amount of particulate collisions and adhering of contaminants on the flow velocity detecting device (hot wire). In additional countermeasure, the hot wire heating temperature is optimized. As a result,

degradation by new contamination in the robust AFS achieves less than 50% of the one of recent AFSs in mass production. The new AFS with the world's maximum robustness against contamination is now released on the market for diesel engine applications. (Started mass production: December 2006)

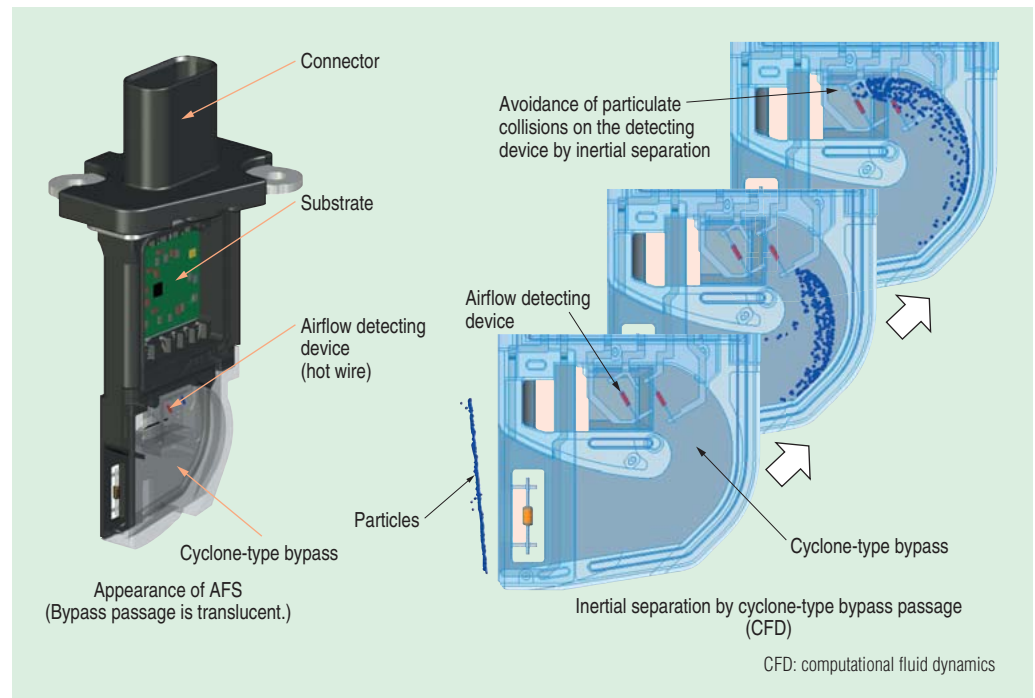

Appearance of new robust AFS for diesel applications (left) and a mechanism of particulates collision avoidance (right)

Image Recognition Software Working with Car Navigation System



An example of recognition of road markings (lane markings)

Recently car navigation systems and camera systems have worked more closely together. Recognition of road markings such as pedestrian crossings and diamond marks (signs that show the presence of a pedestrian crossing ahead) via the back camera has enabled position correction in navigation systems.

Hitachi has developed software that enables detection of road markings (lane markings, pedestrian crossings, and speed-limit markings, etc.), using images from a back camera, based on its detection technology for lane markings using a front camera.

Renesas Technology Corp.'s microcomputer has been adopted into Hitachi's long-standing image processing processor to operate this navigation software. The software has been improved to operate more efficiently.

Unification of the Development Environment for Car Control MBD

Hitachi is promoting an application of MBD (model based development) as a control development method for cars. MBD is for quality improvement and shortening of the development period by modeling a control unit and a control object with CAE (computer aided engineering) tools from an initial stage of the development and using a model in each process. When applying tools such as CAE tools (MATLAB® /Simulink® of The MathWorks, Inc.) or code generation tools (TargetLink® of dSPACE GmbH) to an

actual control development process for cars and managing it, it is essential that design engineers can carry out the work of each process precisely without delay. Therefore Hitachi established unification development environment for car control MBD that has the following advantages to realize an MBD tool chain.

[Main features]

(1) A way to appoint design object files collectively in each series of the development cycle has been adopted so that design engineers do not make mistakes in the design object of each process.

(2) GUI (graphical user interface) based on the flow of the development process has been layered and arranged so that design engineers can work each process smoothly without making omissions.

Hitachi will push forward cooperation with the software unification development environment of the open source in future for further improvements in efficiency of the software development process.

* See “Trademarks” on page 90.

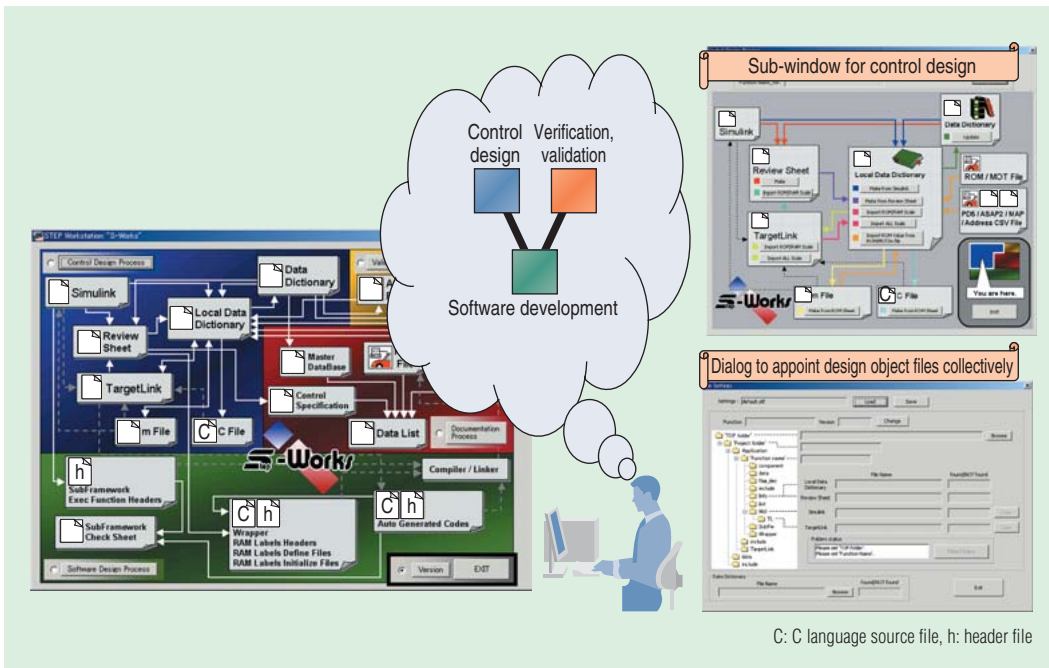

Overview of unification development environment

C: C language source file, h: header file

New 4WD VDC with Coordination Function

Recently the 4WD (four-wheel drive) control has started to be applied for controlling car handling behaviors. Hitachi has developed a new 4WD VDC (vehicle dynamic control) with a coordination function.

This function was initially developed for the 4WD vehicles using electric control coupling devices, and it allows for optimized 4WD torque distribution, based on the data on car behaviors obtained by analyzing sensor signals via the VDC, including steering efforts and yawing rate.

While ensuring safety through the VDC, this coordinated control will allow for maximum utilization of available drive torques as the 4WD, enabling the driver to control steering as desired when turning on the low μ road while accelerating.



New 4WD VDC with coordination function

High Pressure, Large Capacity Variable-displacement Power Steering Pump



Appearance of high pressure, large capacity variable-displacement power steering pump

In response to global warming, improved fuel efficiency is required for automobiles. This VDP (variable-displacement power steering pump) is designed to reduce the torque consumption by adjusting the displacement based on the flow required from the power steering system, eliminating unnecessary workload. This pump contributes to better fuel efficiency than standard fixed-displacement pumps. Therefore, cooling pipes can be reduced or simplified because of reduced heat generation. Current VDP is used for passenger cars, especially for luxury cars because it provides a good feeling for hydraulic steering.

Hitachi has developed the higher pressure (up to 14 MPa), larger capacity (up to 14 cc/rev) VDP than current one in response to the recent demand for medium-size trucks.

Continuous Variable Valve Event and Lift Control System

VEL (continuous variable valve event and lift control system) is a highly functional variable valve system that provides continuous control of both valve event (opening duration) and lift. VEL contributes to not only fuel economy (CO₂ reduction) and low emission, but also driving performance (response, power, torque). The valve train system converts drive-shaft rotation into valve lift operation. VEL provides high-speed performance of 7,500 rpm thanks to multi-link mechanism, which means forced drive function. This contributes to high revolution and high engine performance.

The actuator changes the control shaft (control cam) phase via a DC (direct current) motor, so as to vary valve lift curves (lift amounts, events). This method achieves quick engine response and low energy consumption owing to a highly efficient ball screw for the reduction mechanism of the actuator. This contributes to superior acceleration as well as fuel economy and low emissions. Moreover, this makes it possible to control torque by valve lifts not using a throttle valve, which means even more fuel economy with extremely low pumping losses.

VEL can change lifts widely from the lowest lift state less than 1 mm to the highest lift state over 12 mm according to the driving condi-

tions, while the conventional system only has a constant lift of about 9 mm.

VEL has been adopted for the Nissan SKYLINE Coupe (Japan), the Infinity G37 (USA) and others.

(Introduced to market in August 2007)

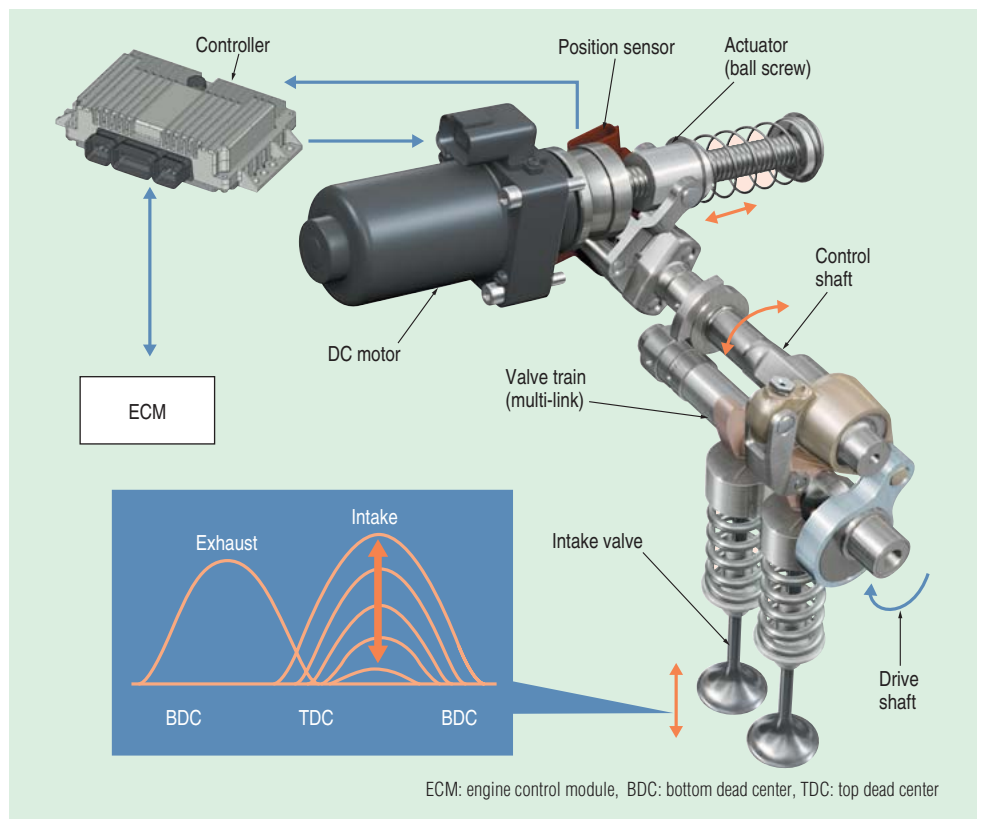

VEL system configuration

Kneel-down Suspension

In response to our rapidly aging society, vehicles that help persons with disabilities get around more freely are attracting much attention. To meet these needs, Hitachi developed a “kneel-down” suspension system that lowers the back of a vehicle height to form a slope to enable a person in a wheelchair to roll in and off the vehicle.

To ensure a reliable kneel-down function, Hitachi developed a shock absorber with very simple structure not much different from standard shock absorbers. To lower the vehicle pressure from a hydraulic pump in the vehicle, the shock absorbers have been compressed and the height of the vehicle reduced. Hitachi adopted the donut-shaped free piston to push down the piston of the shock absorber. Using a tandem seal Hitachi achieved good seal performance and enhanced riding comfort, which normally are contradictory functions. These improvements were made possible based on Hitachi’s experience with hydraulic suspension systems

using high-pressure sealing.

Toyota Motor Corporation used this product in their NOAH van of the “Welcab Series.”

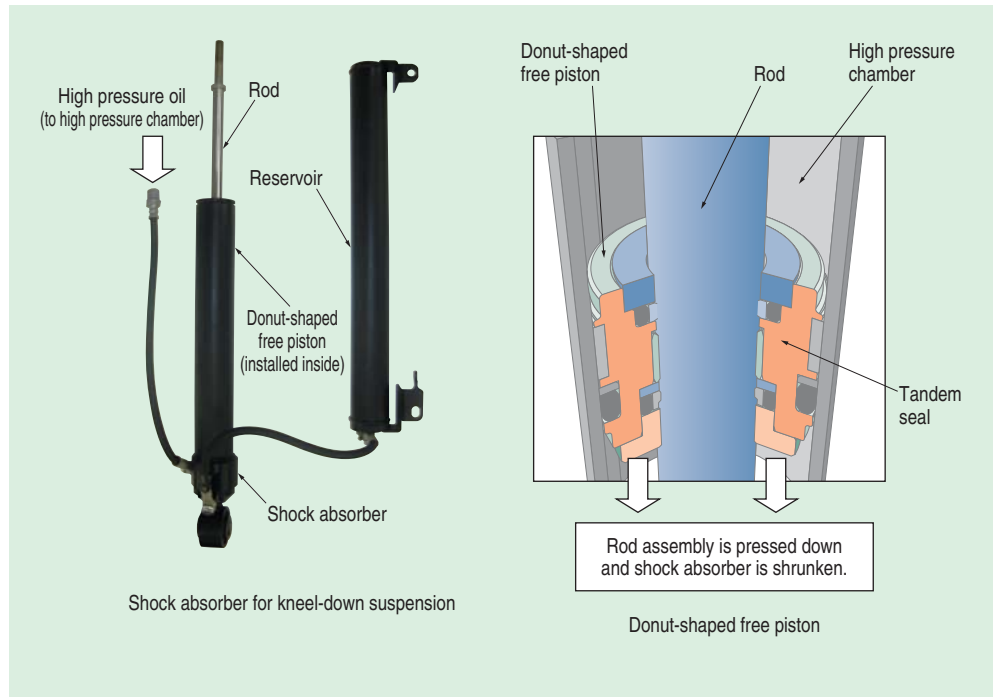

Shock absorber for kneel-down suspension

iFF Master Cylinder

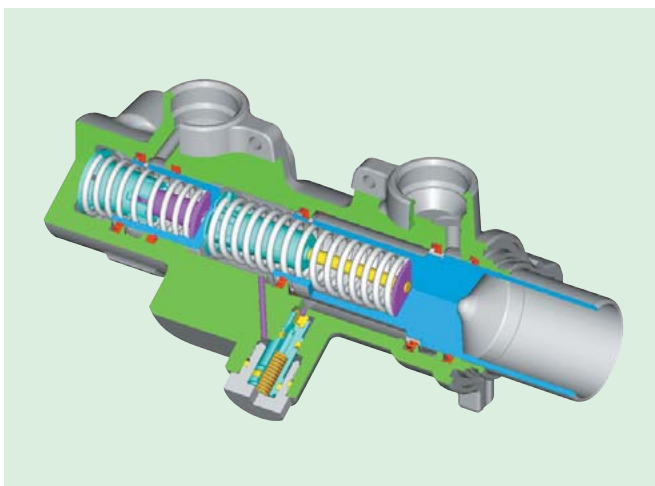

iFF master cylinder cut model

Recently Hitachi has developed the iFF (inovated fast fill) master cylinder that uses a fast fill valve as a hydraulically-controlled mechanical valve, aimed at supporting the VDC (vehicle dynamic control) for the four-wheel drive vehicles, complying with the USA FMVSS (Federal Motor Vehicle Safety Standards) law (requirement for preventing defective boosters) and improving drag performance.

[Main features]

- (1) Master cylinder structure that eases installation in a wide variety of vehicle layouts, while supporting the VDC
 - (2) Stable fast fill effect (reduced pedal stroke effect) that is independent from pedal depressing speed
 - (3) Smooth changes from hydraulic pressure of the large diameter chamber to that of the small diameter chamber
- (Production started in August 2007)

Car Navigation System for Commercial Vehicles

Hitachi and Clarion Co., Ltd. have co-developed a car navigation system for commercial vehicles that has heavy-duty robustness and superior performance for professional communications. Considering the prolonged lives of these vehicles compared to passenger cars, the product is specially designed for heavy-duty operation by eliminating moving parts such as the DVD (digital versatile disc) mechanism and fans as well as adopting flash memory as the storage media for geographic information. It operates on both 12 V and 24 V without a transformer on vehicles including trucks and buses. In order to work well with the systems of commercial vehicle operators, the product is provided with standard interfaces that can be connected to a variety of communication modules used in such systems. The interfaces support the following functions:

- (1) Notification of vehicle information (location, moving direction and speed, etc.) to the operators' systems
- (2) Display of business-related messages sent to the

navigation screen in the vehicle from the operators' systems as well as responses to them

- (3) Designation of specific destinations by the operators' system, as well as registration and deletion of particular location information

The products are designed for deployment as vehicle navigation/fleet management systems for taxi companies with a medium to large number of cabs, as well as for operators of commercial vehicles including trucks and buses.



Car navigation system for commercial vehicles

All AV Navigation Models to Support Terrestrial Digital Broadcasting

Clarion Co., Ltd. developed five models in spring 2007 for the Japanese version of their AV (audio-visual) car navigation systems with built-in HDD (hard disk drive). Clarion sought and achieved

to support a variety of media types and high-quality audio and video performance as well as the ease of use required for car navigation systems. All five models are equipped with receivers for terrestrial digital TV (television) broadcasting to offer a comfortable and pleasant driving experience. The top-end model is provided with a terrestrial digital tuner to receive both 12-segment and one-segment broadcasting that can display high quality video images on its VGA (video graphics array) screen. In addition to various functions including iPod* video support and Music Catcher, a sound restorer function compensates high-frequency losses to make the reproduced sound closer to the original. For the two fall models, the tuners were upgraded to a "4-antenna x 4-tuner" type that allows receiving of 12-segment broadcasting for broader areas.

(Clarion Co., Ltd.)

* See "Trademarks" on page 90.



All AV navigation model to support terrestrial digital broadcasting

Clarion DVD Center Unit and DVD Changer Deployed on the ISS

The NASA (National Aeronautics and Space Administration) has decided to deploy Clarion's wide 7-inch DVD (digital versatile disc) AV (audio-visual) center, the VRX935VD, and its six-disc DVD changer, the VCZ625, (both USA models) for entertaining astronauts and scientists on the ISS (International Space Station). In selecting the products, NASA conducted very strict tests on DVD products from major vehicle equipment manufacturers that operate on 12-V voltage. In deciding, NASA recognized that

Clarion's products support various types of media including DVD, CD (compact disc), CD-R (recordable)/RW (rewritable) and MP3 [MPEG (moving picture experts group)-1 audio layer 3] and noted their proven heavy-duty performance as vehicle DVDs. This is the first time that any automotive AV equipment such as this DVD center and DVD changer will be used on the ISS. (Clarion Co., Ltd.)



Clarion ISS DVD set (a), Clarion ISS DVD main unit (b), and Clarion ISS DVD changer (c)

SU-1500 SEM with Compact Size and High Resolution

SEMs (scanning electron microscopes) are used to observe the surface microstructures of substances in a variety of industrial applications. Recently interest has been more focused on very compact, high performance SEMs that can easily be installed closer to development and production sites to improve lead time for product development and manufacturing.

To meet these demands, Hitachi has now launched the SU-1500 that has similar high image resolution (3.0 nm for secondary electron image) to that of the high-end thermal-emission gun type SEM (Hitachi's SEMs S-3700N and S-3400N), while reducing the work area space required for the SEM to the width of 55 cm.

[Main features]

- (1) The width of the SU-1500 was reduced to 55 cm, which is a reduction of more than 20% compared to Hitachi's conventional S-3000N.
- (2) Secondary electron image resolution of 3.0 nm (high vacuum, accelerating voltage: 30 kV) and 4.0 nm backscattered electron image resolution (low vacuum: 6 Pa) are guaranteed.
- (3) The product incorporates a low-vacuum function as a standard feature. This increases productivity by allowing quick and easy imaging and EDX (energy dispersive X-ray) microanalysis of non-conductive samples.
- (4) The product can handle samples up to 153 mm in diameter. Hitachi has developed a new sample chamber/sample stage that enables the observation and EDX analysis of samples up to 60 mm.
- (5) The product also incorporates many other options including

the ESED (environmental secondary electron detector) -II that allows secondary electron image observation under low vacuum conditions and a three-dimensional view and measurement software that enables SEM images to be converted to three-dimensional data without tilting samples. (Hitachi High-Technologies Corporation)



SEM SU-1500

Microwave ECR Plasma Etching System M-712XT



Microwave ECR plasma etching system M-712XT

Hitachi has now launched a new silicon etching system that supports the manufacture of 300-mm wafers using proven microwave ECR (electron cyclotron resonance) technology combined with the latest, enhanced yield, and productivity improvement technology. The product can incorporate two etching chamber units and two ashing units. It also supports the APC (advanced process control) as an option.

[Main features]

- (1) Yield improvement: high speed uniform exhaust capabilities with advanced temperature control electrodes
 - (2) Productivity improvement: reduction of wall area of a chamber, complete swappable kit and support for in-situ cleaning
- (Hitachi High-Technologies Corporation)

High Speed Modular Mounter GXH-3

Hitachi has now launched a high speed modular mounter (electronic parts mounting system), the GXH-3 that has enhanced throughput about 20% higher than Hitachi's conventional mounters.

This product uses the direct drive head mechanism with 12 nozzles mounted in a circumferential direction, has a linear motor to the XY drive axes, and employs a function for instant visual recognition of 12 parts at each of the 12 nozzles. These are all features from conventional GXH-1S series that Hitachi has enhanced in the GXH-3 by improving the speed by reviewing the element, structure, and sequencing operations.

[Main features]

- (1) The product has achieved high throughput of 95,000 chips/h by speeding up overlapping operations using a newly developed direct drive head mechanism and feeder operations of electronic parts.
 - (2) The product also implements the cutting-edge, high quality mounting through a function that enables detection and feedback of deflection of substrates and soft-mounted nozzles that reduce impact from parts when installed.
- (Hitachi High-Tech Instruments Co., Ltd.)



High speed modular mounter GXH-3

Liquid Chromatograph Mass Spectrometer

Enabling Structure Analysis of Accessory Protein NanoFrontier eLD

Proteins are molecules made of 20 different amino acids joined together in a linear chain and they are responsible for all the functions necessary for human motions. Phosphoric acids or sugar chains are combined chemically with proteins to generate accessory proteins inside the body. These accessory proteins develop different functions depending on the types of modifying moieties and their bonding locations inside proteins. Much attention is paid to proteins currently, as many diseases are considered to have relevance to abnormal proteins or accessory proteins, and clarification of the correlation will lead to creation of new medicines as well as better diagnosis at earlier stages.

One of the effective instruments to analyze the structure of proteins or accessory proteins is a liquid chromatograph mass spectrometer. This instrument takes ions inside it and cuts a weakened part of the molecule structure using the CID (collision induced dissociation) method to analyze the structure. A modifying moiety, however, is

easily cut from a protein using this method, and it was difficult to identify the bonding location inside the protein.

The newly developed and launched NanoFrontier eLD incorporates the ECD (electron capture dissociation) method in addition to the CID method. In this method, electron beams will be radiated inside the LIT (linear ion trap) to cause dissociation using interaction with ions inside the LIT. In this method, a modifying moiety is not easily cut from the amino acid sequence and location information is obtainable. Also as it dissociates all amino acids with equal probability, it facilitates the analysis of the structure of a sample with relatively heavy molecular weight.

It is intended to contribute to creation of new medicines and diagnosis at earlier stages, since a new insight can be gained by biomarker exploration and analysis of proteins by analyzing accessory proteins.

(Hitachi High-Technologies Corporation)

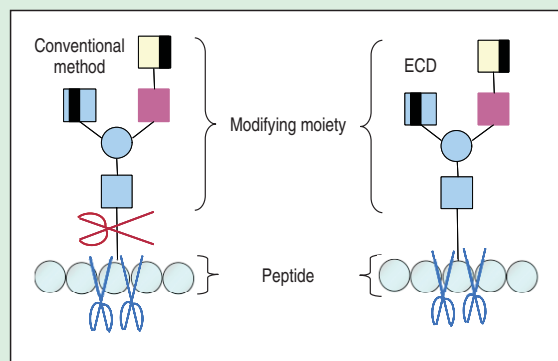

Difference of dissociation between the conventional method and the ECD method (upper) and appearance of NanoFrontier eLD (lower)