

2002/6/28 Release

Joint research by Hitachi, Ltd. and Denso Corporation on a voice control system for next-generation car information services

- using enhanced VoiceXML technology to adapt to change in conversation topics -

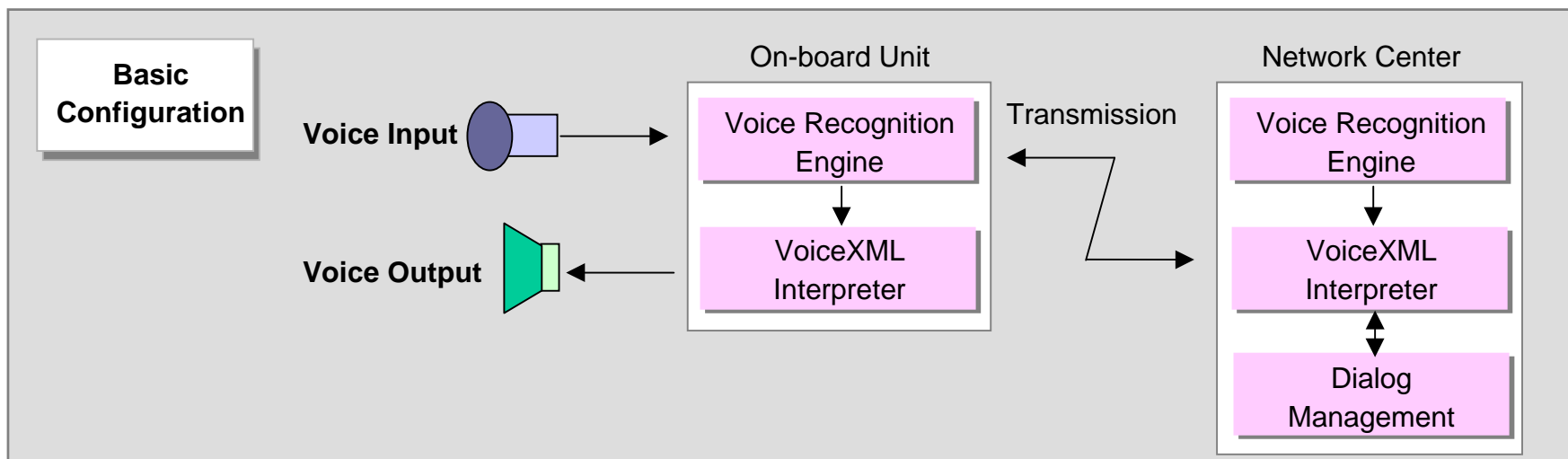

Hitachi Ltd. and Denso Corporation, in joint research with Carnegie Mellon University (USA), have commenced the development of a dialogue-based voice operated system for next-generation on-board information services. The system will enable a driver to easily obtain information through voice access to the Internet, etc. This collaboration which began in September 2001, has resulted in the development of the basic configuration for the dialogue based voice system by Hitachi, Denso and CMU.