

2007/1/10 Release

## Development of a technique to simplify complex electrical wiring using “ $\mu$ -Chip”

- Increased reliability & efficiency in cable construction works in power plants -

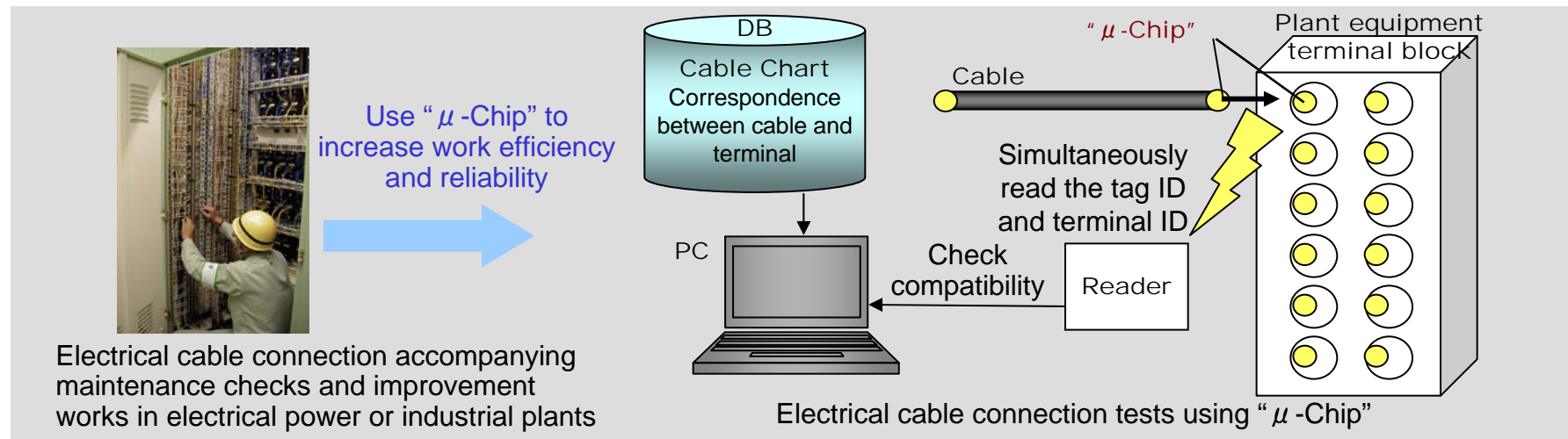

Hitachi, Ltd. has developed a technique of simplifying the complex and time-consuming process of connecting and testing electrical cable connections, using “ $\mu$ -Chip” technology. A “ $\mu$ -Chip” is affixed to both the cable and the equipment terminal. The ID of both chips are read and checked against design plans, etc. to confirm that the cable has been connected to the correct terminal. In the past, such cable construction/connections which are part of maintenance check or improvement works in large electrical power and industrial plants, were conducted visually and consumed much time. Application of this technology not only simplifies the process but also improves work efficiency and reliability.